

where $x(0) = x_0$ is the initial value of $x(t)$.

Interestingly, this is *almost* a scalar multiple of $u(t)$ - if only we could ignore the initial term involving $e^{\lambda t}$, then $x(t)$ would linearly depend on $u(t)$. Can we ignore this term? We can only do so by arguing that it goes to zero over time. Then, our "steady state" solution for $x(t)$ would involve only the e^{st} term, which seems to make our lives a lot easier.

When might that happen? Specifically, when does $e^{\lambda t} \rightarrow 0$ as $t \rightarrow \infty$? If λ were real, then the term decays to zero if and only if $\lambda < 0$. But what about for complex λ ? We can try writing a complex λ in the form $\lambda = \lambda_r + j\lambda_i$, to try and reduce the problem to the real case. That is:

$$\begin{aligned} e^{\lambda t} &= e^{(\lambda_r + j\lambda_i)t} \\ &= e^{\lambda_r t} e^{j\lambda_i t} \end{aligned}$$

The $e^{\lambda_r t}$ is exactly the real case we just saw above. But what about the $e^{j\lambda_i t}$ term? Well, the only thing we can really do here is apply Euler's formula. Expanding our expression, we find that

$$e^{\lambda t} = e^{\lambda_r t} (\cos(\lambda_i t) + j \sin(\lambda_i t))$$

This expression seems promising! The first term in the product is a real exponential, which we know decays to zero exactly when $\text{Re}[\lambda] = \lambda_r < 0$. The second term is a sum of two sinusoids with unit amplitudes. Since the amplitude of each sinusoid is constant, their sum will not decay to zero or grow to infinity over time. Thus, the asymptotic behavior of the overall expression is governed solely by the first term ($e^{\lambda t}$ will decay to zero exactly when $e^{\lambda_r t}$ does). From earlier, we can see that this happens when $\lambda_r < 0$.

Looking back at our solution for $x(t)$, we now have a way to determine when the $e^{\lambda t}$ decays, and the condition can be applied for both real and complex λ .

3 Systems of Linear First-Order Differential Equations

Can we apply similar techniques to what we've just seen to a system of differential equations? Specifically, consider the system

$$\frac{d}{dt} \vec{x}(t) = A\vec{x}(t) + \vec{u}(t),$$

where A is a fixed, real, matrix. As before, we will consider only control inputs of a special form, where each component is of the form ke^{st} for some constant k . Said differently, we will only examine cases where $\vec{u}(t)$ can be expressed in the form

$$\vec{u}(t) = \vec{u} e^{st},$$

where \vec{u} does not depend on t , and s is *not* an eigenvalue of the matrix A .

Inspired by our previous observations, let's make the guess that our solution $x(t)$ can be written as

$$\vec{x}(t) = \vec{x} e^{st}$$

where \vec{x} does not depend on t . Substituting into our differential equation, we find that

$$\begin{aligned} \frac{d}{dt} (\vec{x}e^{st}) &= A\vec{x}e^{st} + \vec{u}e^{st} \\ s\vec{x}e^{st} &= A\vec{x}e^{st} + \vec{u}e^{st} \\ (sI - A)\vec{x}e^{st} &= \vec{u}e^{st}. \end{aligned}$$

Since the above equality must hold true for all t , we can equate the coefficients of e^{st} to obtain

$$(sI - A)\vec{x} = \vec{u}.$$

Now, to express \vec{x} in terms of \vec{u} , we are tempted to multiply by the inverse of $sI - A$ on both sides. Recall that our working assumption for this analysis is that s is not an eigenvalue of A . Before taking the inverse, can we use our assumption to show this operation is valid? To proceed with proof by contradiction, imagine that $sI - A$ is not invertible (that is, $sI - A$ has a nonempty null space, containing some vector \vec{y}). We could then write:

$$\begin{aligned} (sI - A)\vec{y} &= \vec{0} \\ \implies A\vec{y} &= s\vec{y} \end{aligned}$$

so s would be an eigenvalue of A with corresponding eigenvector \vec{y} . But our assumption is that s is not an eigenvalue of A , so our "proof-by-contradiction" assumption that $sI - A$ is not invertible must have been wrong ($sI - A$ must be invertible).

Thus, we can rearrange our equation for \vec{x} above, to express

$$\vec{x} = (sI - A)^{-1}\vec{u}.$$

It is straightforward to substitute this back into the expression for $x(t)$ and verify that it does indeed correspond to a valid solution for our original system of differential equations.

This is great! Starting with a system of differential equations with an input of a particular form, we can now use the above identity to construct a solution for $\vec{x}(t)$ without calculus!

But is this solution the one we will reach in the steady state? Assume, for simplicity, that A has a full set of eigenvectors $\vec{v}_1, \dots, \vec{v}_n$ with corresponding eigenvalues $\lambda_1, \dots, \lambda_n$. Then we know that we can diagonalize A to be

$$\begin{aligned} A &= \begin{bmatrix} | & & | \\ \vec{v}_1 & \cdots & \vec{v}_n \\ | & & | \end{bmatrix} \begin{bmatrix} \lambda_1 & 0 & \cdots & 0 \\ 0 & \lambda_2 & \cdots & 0 \\ \vdots & \vdots & \ddots & \vdots \\ 0 & 0 & \cdots & \lambda_n \end{bmatrix} \begin{bmatrix} | & & | \\ \vec{v}_1 & \cdots & \vec{v}_n \\ | & & | \end{bmatrix}^{-1} \\ &= V\Lambda V^{-1}, \end{aligned}$$

where V and Λ are the eigenvector and eigenvalue matrices in the above diagonalization.

Thus, we can rewrite our differential equation for $x(t)$ as:

$$\begin{aligned}\frac{d}{dt}\vec{x}(t) &= V\Lambda V^{-1}\vec{x}(t) + \vec{u}(t) \\ \frac{d}{dt}\left(V^{-1}\vec{x}(t)\right) &= \Lambda(V^{-1}\vec{x}(t)) + V^{-1}\vec{u}(t).\end{aligned}$$

As we have seen, this diagonalized (uncoupled) system of differential equations can be rewritten as a set of scalar differential equations of the form

$$\frac{d}{dt}\left(V^{-1}\vec{x}(t)\right)_i = \lambda_i\left(V^{-1}\vec{x}(t)\right)_i + \left(V^{-1}\vec{u}(t)\right)_i,$$

where the subscripted i represents the i th component of the associated vector, and λ_i is the i th eigenvalue of A .

Since $\left(V^{-1}\vec{u}(t)\right)_i$ is a multiple of e^{st} and $s \neq \lambda_i$, we know from our scalar results that the solution to $\left(V^{-1}\vec{x}(t)\right)_i$ can be expressed as a linear combination of $e^{\lambda_i t}$ and e^{st} , where the $e^{\lambda_i t}$ decays to zero over time if and only if $\text{Re}[\lambda_i] < 0$, yielding a steady state solution involving only a scalar multiple of e^{st} . Let this solution be:

$$\left(V^{-1}\vec{x}(t)\right)_i = \vec{x}_i e^{st}.$$

Thus, we can stack these solutions for i and pre-multiply by V to obtain

$$\begin{aligned}V^{-1}\vec{x}(t) &= \vec{\tilde{x}}e^{st} \\ \vec{x}(t) &= (V\vec{\tilde{x}})e^{st}.\end{aligned}$$

Now, recall that our candidate solution $\vec{x}(t) = \vec{\tilde{x}}e^{st}$ was constructed to be the unique solution to our system that was a scalar multiple of e^{st} . Thus, our candidate solution is exactly the steady state solution to the system, which we will converge to exactly when the real components of all the eigenvalues λ_i of our state matrix A are less than zero.

4 Circuits with Exponential Inputs

For a large circuit involving resistors, capacitors, and inductors, if we tried to solve the circuit using differential equations, every capacitor and inductor adds an extra derivative to the system. Now let's take a look at what happens if our circuit was driven by inputs of the exponential function e^{st} for some constant s .

Consider a particular capacitor C within the circuit, with node voltages $v_+(t)$ and $v_-(t)$ at its two terminals (defining a capacitor voltage $v_C(t)$) and a current $i_C(t)$ flowing through it.:

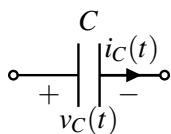

At steady state, we know from our understanding of the differential equation story above that:

$$v_C(t) = \tilde{V}_C e^{st} \quad i_C(t) = \tilde{I} e^{st}$$

for some scalars \tilde{V}_C and \tilde{I}_C .

By the known differential equation for a capacitor, we have that

$$\begin{aligned} i_C(t) &= C \frac{d}{dt} v_C(t) \\ \tilde{I}_C e^{st} &= C \frac{d}{dt} (\tilde{V}_C e^{st}) \\ \tilde{I}_C e^{st} &= Cs(\tilde{V}_C) e^{st} \\ \implies \tilde{I}_C &= Cs(\tilde{V}_C). \end{aligned}$$

Critically, this equation resembles that of Ohm's Law! It is a purely linear equation without any time-dependence.

Similar equations can be obtained (this is a useful exercise to do) for an inductor $\tilde{V}_L = \tilde{I}_L \cdot sL$ and a resistor $\tilde{V}_R = \tilde{I}_R \cdot R$. Rewriting the capacitor relationship to be in the same form, we see $\tilde{V}_C = \tilde{I}_C \cdot (\frac{1}{Cs})$. This suggests that we can view capacitors, inductors, and resistors as all being similar. In effect, capacitors and inductors just have s -dependent resistances. These are called s -impedances. The term impedance is a generalization of the concept of resistance to allow for different resistances at different s -values (we will soon see what governs the value of s in a circuit context.). The impedance is defined as the voltage-current ratio (similar to resistance):

$$\tilde{Z} = \frac{\tilde{V}}{\tilde{I}}$$

A capacitor has an s -impedance of $\frac{1}{Cs}$. An inductor has an s -impedance of Ls . And a resistor's s -impedance is just the same as its resistance R .

This reveals an approach for circuit analysis with exponential inputs, as long as all the inputs have the same s . We can replace all the independent voltage and current sources with constant voltages and currents corresponding to only the coefficients of e^{st} . We replace all capacitors and inductors with their corresponding impedances, and then analyze the entire circuit as though it only had resistances it it. This can be solved using the circuit analysis techniques studied in 16A, and we can interpret the results to get the steady-state solution for the system.

5 Sinusoids and Phasors

Unfortunately, there's one big issue with all the work we've done so far - specifically, the restrictions we imposed on our input $\vec{u}(t)$. We stated that $\vec{u}(t)$ should be expressed as

$$\vec{u}(t) = \vec{u} e^{st}$$

for some s . What kinds of s are probably useful? If $\text{Re}(s) < 0$, then we know that the input approaches zero over time, so the steady state behavior of our system is probably not very interesting. Similarly, if $\text{Re}(s) > 0$, then our input will grow to infinity over time, so our state will blow up! This only leaves the case $\text{Re}(s) = 0$ as neither blowing up or decaying away.

So then what can our input look like? If $\text{Re}(s) = 0$, then s must be purely imaginary. So our input will be a linear function of e^{st} , where s is a real multiple of j . From Euler's formula, we know that term has some sort of periodic, sinusoidal behavior.

Consider the function $x(t) = A \cos \omega t$, where $x(t)$ can be thought of as representing an input in our circuit,

like an alternating current or voltage.

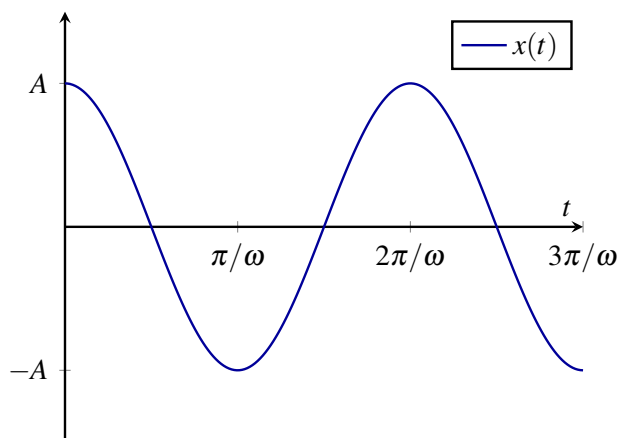

There are a couple properties of $x(t)$ that are apparent from the figure: we call the maximum value of $x(t)$ above the mean (in this case, the x -axis) the *amplitude* (A), and the spacing between repetitions of the function the *period* ($T = 2\pi/\omega$).

However, there's one other important property of sinusoids: their *phase*. Consider a similar function $y(t) = A \cos(\omega t + \phi)$.

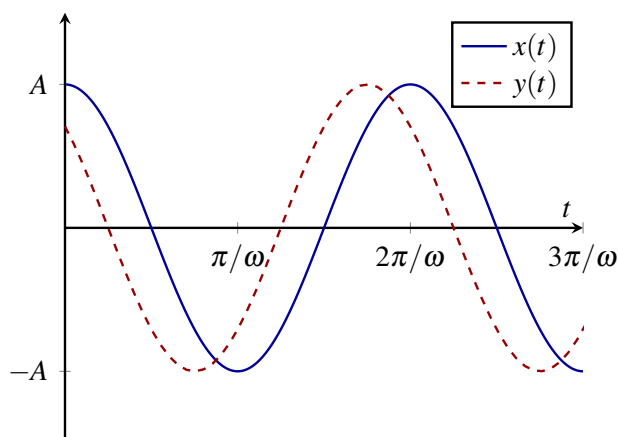

Here, ϕ represents the *phase shift* of $y(t)$ with respect to $x(t)$. As can be seen, a positive phase shift moves the function to the left by that amount. In particular, notice that the sine and cosine functions are really the same sinusoid! It's just that there is a $\pi/2$ radian phase shift between them.

Now that we know a little about sinusoids, let's see how we can express a sinusoidal voltage input $v(t) = V_0 \cos(\omega t + \phi)$ in terms of exponential functions. To do this, we will use complex numbers. We can combine Euler's formula with the properties of complex conjugates to determine that

$$e^{j\theta} + e^{-j\theta} = (\cos(\theta) + j\sin(\theta)) + (\cos(\theta) - j\sin(\theta)) = 2\cos(\theta).$$

In other words, starting with two complex exponentials, we have pulled out a purely real sinusoid! From the

above definition, we have that

$$\begin{aligned}\cos(\theta) &= \frac{1}{2}e^{j\theta} + \frac{1}{2}e^{-j\theta} \\ \implies \cos(\omega t + \phi) &= \frac{1}{2}e^{j\omega t + j\phi} + \frac{1}{2}e^{-j\omega t - j\phi} \\ &= \frac{e^{j\phi}}{2}e^{j\omega t} + \frac{e^{-j\phi}}{2}e^{-j\omega t} \\ \implies v(t) &= V_0 \cos(\omega t + \phi) \\ &= \frac{V_0 e^{j\phi}}{2}e^{j\omega t} + \frac{V_0 e^{-j\phi}}{2}e^{-j\omega t}.\end{aligned}$$

Therefore, we can express an arbitrary sinusoid $v(t)$ as a linear combination of two exponential functions! Notice that the coefficients of the two exponential functions are complex conjugates of one another. Thus, we can rewrite the above as:²

$$v(t) = \frac{V_0 e^{j\phi}}{2}e^{j\omega t} + \frac{\overline{V_0 e^{j\phi}}}{2}e^{-j\omega t}.$$

Thus, the coefficient of the $e^{j\omega t}$ can be used to represent the entire sinusoid $v(t)$ (assuming the frequency ω is known). We call this coefficient the *phasor* representing $v(t)$, and denote it as

$$\tilde{V} = \frac{V_0 e^{j\phi}}{2}.$$

Now, we know how to find the steady states of systems of differential equations with sinusoidal inputs! First, use the above transformation to write the input as a linear combination of exponential functions e^{st} . Then, for each exponential function, solve the equation $\vec{x} = (sI - A)^{-1}\vec{u}$ to determine the steady state solution $\vec{x}(t) = \vec{x}e^{st}$.³ Finally, take the superposition of all these steady states, to obtain the steady state corresponding to the entire original input. We see a small symbolic example of this below.

This approach works great! But there's one further optimization we can add to simplify calculations. Let's consider the case when we are working with real, sinusoidal inputs of a fixed frequency ω . Then we know that our input can be represented as a linear combination of inputs of the forms $e^{j\omega t}$ and $e^{-j\omega t}$.

But, from our above construction, we know that this can't be just *any* linear combination! Specifically, the coefficients of $e^{j\omega t}$ and $e^{-j\omega t}$ must be complex conjugates of one another! Thus, we can write our input as

$$\vec{u}(t) = \vec{u}e^{j\omega t} + \overline{\vec{u}}e^{-j\omega t}.$$

Now, let our system be

$$\frac{d}{dt}\vec{x}(t) = A\vec{x}(t) + \vec{u}(t).$$

When $\vec{u} = \vec{u}e^{j\omega t}$, we know that the steady state $\vec{x}_1 e^{j\omega t}$ for $\vec{x}(t)$ is such that

$$(j\omega I - A)\vec{x}_1 = \vec{u}.$$

²Recall that $e^{-j\theta} = \overline{e^{j\theta}}$.

³Going forward, we will consistently use capital letters for phasors corresponding to lower-case time-domain sinusoidal quantities. Here, \vec{x} and \vec{u} are vectors of scalars, not phasors.

Similarly, when $\vec{u} = \vec{u} e^{-j\omega t}$, we know that the steady state $\vec{x}_2 e^{-j\omega t}$ for $\vec{x}(t)$ is such that

$$(-j\omega I - A)\vec{x}_2 = \vec{u}.$$

Then, we take the superposition of these two solutions to find the overall steady state solution:

$$\vec{x}(t) = \vec{x}_1 e^{j\omega t} + \vec{x}_2 e^{-j\omega t}.$$

This solution works, but it requires us to solve two linear equations to find both \vec{x}_1 and \vec{x}_2 . These quantities appear to be fairly similar; is the relationship between them predictable? That is, can we solve for \vec{x}_2 in terms of \vec{x}_1 ?

The key observation to make is that (since A is a real matrix and $\bar{A} = A$):

$$\overline{j\omega I - A} = -j\omega I - A,$$

Thus, starting from the known solution for \vec{x}_1 , we can take complex conjugates to obtain

$$\begin{aligned} (j\omega I - A)\vec{x}_1 &= \vec{u} \\ \implies \overline{(j\omega I - A)\vec{x}_1} &= \vec{u} \\ \implies (-j\omega I - A)\vec{x}_1 &= \vec{u}. \end{aligned}$$

The above equation is exactly the equation that \vec{x}_2 has to satisfy. Matching terms from our earlier expression, we see that

$$\vec{x}_2 = \vec{x}_1,$$

so we can substitute and write our final solution for $x(t)$ as

$$\vec{x}(t) = \vec{x}_1 e^{j\omega t} + \vec{x}_1 e^{-j\omega t}.$$

So only one round of Gaussian elimination (or linear equation system solving generally) is needed, not two!

6 Circuit Quantities: Phasors

In principle, at this point we already know what to do when given a circuit with sinusoidal inputs all at the same frequency. But it can be helpful to revisit and solidify the derivations.

Let's apply the technique we've just developed to study the steady-state behavior of capacitors and inductors when supplied with a sinusoidal voltage or current signal. One key insight will help us proceed; with a phasor, we are representing a sinusoid by its amplitude and phase, but not the frequency. In fact, the frequency is tied to time as part of the ωt term, and in the section above, we noted that the phasor represents the *entire sinusoid*. We found this convenient mathematically, and could do this only because linear circuits (resistors, capacitors, and inductors) will never alter the frequency of a sinusoid. Why? This property comes from the fact that our generalized exponential input term, e^{st} , is an eigenfunction of differentiation (which appears in the definitions of inductor voltages and capacitor currents). Any sinusoid will be expressed in terms of $e^{j\omega t}$ and $e^{-j\omega t}$; let's take a closer look at an example to understand this.

6.1 Impedance of a Capacitor

We examine a capacitor provided with the sinusoidal voltage $v_C(t) = V_0 \cos(\omega t + \phi)$, as shown:

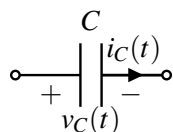

Note that we aren't assuming anything about the origin of the $v(t)$ – it could come from a voltage supply directly, or from some other complicated circuit. From before, we know that $v(t)$ has a phasor representation. Since:

$$v_C(t) = \frac{V_0 e^{j\phi}}{2} e^{j\omega t} + \frac{V_0 e^{-j\phi}}{2} e^{-j\omega t},$$

it can be represented by the phasor

$$\tilde{V}_C = \frac{V_0 e^{j\phi}}{2}.$$

Now, by the capacitor equation, we know that:

$$\begin{aligned} i_C(t) &= C \frac{d}{dt} v_C(t) \\ &= C \frac{d}{dt} \left(\frac{V_0 e^{j\phi}}{2} e^{j\omega t} + \frac{V_0 e^{-j\phi}}{2} e^{-j\omega t} \right) \\ &= C \frac{d}{dt} \left(\tilde{V}_C e^{j\omega t} + \tilde{V}_C^* e^{-j\omega t} \right) \\ &= C \left(\tilde{V}_C (j\omega) e^{j\omega t} + \tilde{V}_C^* (-j\omega) e^{-j\omega t} \right) \\ &= (j\omega C) \tilde{V}_C e^{j\omega t} + (-j\omega C) \tilde{V}_C^* e^{-j\omega t} \end{aligned}$$

Noting that we find phasors by taking the coefficient of the $e^{j\omega t}$ term (and recognizing that the coefficient of the $e^{-j\omega t}$ term is guaranteed to be the complex conjugate.). So we can represent the current as the phasor

$$\tilde{I}_C = (j\omega C) \tilde{V}_C.$$

In other words, having already shown that all steady state circuit quantities will be sinusoids with frequency ω in response to the input voltage, we can relate the phasors of the voltage across and the current through a capacitor by a ratio that depends only on the frequency and the capacitance.

This is exactly the same as the s -impedance story we told earlier. When dealing with sinusoidal inputs at frequency ω , we use $s = +j\omega$ and just call the s -impedance, the *impedance*. The $+j\omega$ is understood from context.

As before, this can be thought of as the "resistance" of a capacitor, since it relates the phasor representations of an element's voltage and current by a constant ratio. For a capacitor, the impedance is

$$Z_C = \frac{\tilde{V}_C}{\tilde{I}_C} = \frac{1}{j\omega C}.$$

Interestingly, the impedance for the capacitor is imaginary.

We will now quickly perform a similar analysis for inductors and resistors.

6.2 Impedance of a Resistor

Imagine some resistor R labeled as follows:

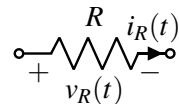

Let $v_R(t)$ be represented by some phasor \widetilde{V}_R . Thus, by Ohm's Law,

$$\begin{aligned} v_R(t) &= \widetilde{V}_R e^{j\omega t} + \widetilde{V}_R^* e^{-j\omega t} \\ \implies i_R(t) &= \frac{1}{R} v(t) \\ &= \frac{\widetilde{V}_R}{R} e^{j\omega t} + \frac{\widetilde{V}_R^*}{R} e^{-j\omega t}, \end{aligned}$$

so we may represent the output current with the phasor

$$\widetilde{I}_R = \frac{\widetilde{V}_R}{R},$$

so the impedance is

$$Z_R = \frac{\widetilde{V}_R}{\widetilde{I}_R} = R.$$

From this, we see that the impedance behaves very much like the resistance does, except that it generalizes to other circuit components.

6.3 Impedance of an Inductor

From our previous consideration of complex numbers, we have seen that any sinusoidal function can be represented by a phasor. Since we know that our steady states will all be sinusoids with the same frequency ω , we can start with a sinusoidal current and work in the opposite direction to calculate the impedance of an inductor, as follows.

Consider an inductor with voltage and current across it as follows:

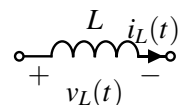

Let the current $i_L(t)$ be represented by some phasor \tilde{I}_L . Thus, by the equation of an inductor,

$$\begin{aligned} i_L(t) &= \tilde{I}_L e^{j\omega t} + \tilde{I}_L^* e^{-j\omega t} \\ \implies v_L(t) &= L \frac{di_L(t)}{dt} \\ &= (j\omega L) \tilde{I}_L e^{j\omega t} - (j\omega L) \tilde{I}_L^* e^{-j\omega t} \\ &= (j\omega L) \tilde{I}_L e^{j\omega t} + \overline{(j\omega L) \tilde{I}_L^*} e^{-j\omega t}, \end{aligned}$$

so the voltage can be represented by the phasor

$$\tilde{V}_L = j\omega L \tilde{I}_L.$$

Thus, the impedance of an inductor is

$$Z_L = \frac{\tilde{V}_L}{\tilde{I}_L} = j\omega L.$$

6.4 A Remark on Conjugation

When we have an expression like $v(t) = \frac{V_0 e^{j\phi}}{2} e^{j\omega t} + \frac{V_0 e^{-j\phi}}{2} e^{-j\omega t}$, we have consistently been defining the phasor as $\tilde{V} = \frac{V_0 e^{j\phi}}{2}$, the coefficient of the $e^{j\omega t}$ term. But what about the conjugate phasor $\tilde{V}^* = \frac{V_0 e^{-j\phi}}{2}$ associated with the complementary exponential, $e^{-j\omega t}$? Why does it not appear in our time-to-phasor-domain transformation?

Well, since the two phasor terms form a complex-conjugate pair, changing one automatically impacts the other. This balance happens in such a way that the ultimate time-domain signal stays fully real-valued. In a sense, having the conjugate phasor is necessary to "cancel out" the imaginary parts from the original phasor. Notice that $e^{j\omega t}$ has a real and imaginary component (think of it as circling around the unit circle in the complex plane.) Its imaginary part can only be cancelled by adding its complex conjugate (for any complex a , $a + \bar{a} = 2\text{Re}\{a\}$, which is fully real.)

7 Circuit Analysis

7.1 Summarizing the Connection Between Time- and Phasor-Domains

Given a general sinusoidal time-domain input signal $u(t) = A \cos(\omega t + \phi)$, we derived a way to conveniently represent $u(t)$ as a weighted sum of a complex exponential $e^{j\omega t}$ and its complex conjugate $e^{-j\omega t}$. This led us to naturally define the phasor, which is a term $\tilde{U} = \frac{A e^{j\phi}}{2}$. We showed how the phasor captures all the critical information about $u(t)$, but without the time-dependent terms. This transformation $u(t) \rightarrow \tilde{U}$ is often called a *Phasor-Transform*.

$$\text{Phasor Transform: } u(t) = A \cos(\omega t + \phi) \rightarrow u(t) = \frac{A e^{j\phi}}{2} e^{j\omega t} + \frac{A e^{-j\phi}}{2} e^{-j\omega t} \implies \tilde{U} = \frac{A e^{j\phi}}{2}$$

Using \tilde{U} , we have seen how to analyze the behavior of R, L, C circuit elements to find their voltages and currents. That's great, but we ultimately want to know what the output voltage or current is as a function of time. This motivates the *Inverse Phasor Transform*. The inverse transformation takes some $\tilde{W} = B e^{j\psi}$ that we've solved for, and converts it into $w(t) = B \cos(\omega t + \psi)$. Notice that the frequency term stayed the

same throughout! This was one of our critical assumptions, related to how the RLC circuits we study only contain elements which preserve the frequency of the sinusoids they act on. They only impact the amplitude and phase.

$$\text{Inverse Phasor Transform: } \tilde{W} = \frac{Be^{j\psi}}{2} \rightarrow w(t) = B \cos(\omega t + \psi)$$

7.2 KCL with Phasors

In previous sections, we have essentially obtained "equivalents" to Ohm's Law for inductors and capacitors, using the impedance to relate their voltage and current phasors.

We will now try to show that a sum of sinusoidal functions is zero if and only if the sum of the phasors of each of those functions equals zero as well, to obtain a sort of "phasor-version" of KCL. Consider the sinusoids represented by the phasors here:

$$\tilde{I}_1, \tilde{I}_2, \dots, \tilde{I}_n.$$

Let $i_k(t)$ be the sinusoid represented by the phasor \tilde{I}_k . Observe that:

$$\begin{aligned} & \tilde{I}_1 + \tilde{I}_2 + \dots + \tilde{I}_n = 0 \\ \iff & (\tilde{I}_1 + \tilde{I}_2 + \dots + \tilde{I}_n)e^{j\omega t} = 0 \\ \iff & (\tilde{I}_1 + \tilde{I}_2 + \dots + \tilde{I}_n)e^{j\omega t} + (\tilde{I}_1 + \tilde{I}_2 + \dots + \tilde{I}_n)e^{-j\omega t} = 0 \\ \iff & \sum_{k=1}^n \tilde{I}_k e^{j\omega t} + \tilde{I}_k e^{-j\omega t} = 0 \\ \iff & i_1(t) + i_2(t) + \dots + i_n(t) = 0, \end{aligned}$$

so we have proved that a sum of sinusoids is zero if and only if the sum of their corresponding phasors is zero as well. This result can be thought of as a generalization of KCL to phasors.

Putting everything together, we have now successfully generalized all of our techniques of DC analysis to frequency analysis.

7.3 Problem-Solving Process

We can outline the key steps to analyze and solve a general circuit using phasors:

- (a) Confirm that the circuit can actually be usefully analyzed using phasors. *This requires the voltages and currents to be sinusoidal!*
- (b) Convert all $v(t), i(t)$ information to the phasor-domain (\tilde{V}, \tilde{I}).
- (c) Solve for the voltages and currents using EECS16A techniques (KCL, KVL, NVA, etc.)
- (d) Convert all phasor results back to the time-domain.

We can now consider some basic circuits, to exercise this technique, and verify that it works correctly. Consider a voltage divider, where we introduce a capacitor in place of one of the resistors, as follows:

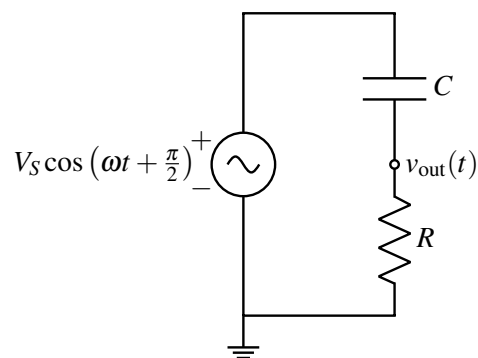

We are interested in knowing how the voltage $v_{\text{out}}(t)$ varies over time in response to the input supply, $u(t) = V_S \cos(\omega t + \frac{\pi}{2})$. Recall that we proved the voltage divider equation in the context of DC circuit analysis. However, that proof carries over to the phasor domain in a straightforward manner. Thus, the phasor \tilde{V}_o representing the voltage $v_{\text{out}}(t)$ can be represented in terms of the phasor \tilde{U} representing the supply voltage as follows:

$$\tilde{V}_o = \frac{Z_R}{Z_C + Z_R} \tilde{U},$$

where Z_C and Z_R are the impedances of the capacitor and resistor, respectively. Note also that, since the supply is at frequency ω , all other voltages and currents in the system will also be at the same frequency ω . The circuit elements do not change this frequency. Thus, using our results from earlier, we know that:

$$Z_C = \frac{1}{j\omega C} \quad Z_R = R$$

Note also that $\tilde{U} = \frac{V_S e^{j\frac{\pi}{2}}}{2} = \frac{jV_S}{2}$, using our equation for $\cos \theta$ from earlier.

Substituting these values into our equation for \tilde{V}_o , we find that

$$\tilde{V}_o = \frac{R}{\frac{1}{j\omega C} + R} \frac{jV_S}{2} = \frac{\frac{jR}{2}}{\frac{1}{j\omega C} + R} V_S.$$

It'll be convenient to have a magnitude-phase representation (and to multiply both top and bottom by $j\omega C$ to rationalize the denominator):

$$\begin{aligned} \tilde{V}_o &= \frac{V_S \frac{jR}{2} j\omega C}{1 + j\omega RC} \\ &= \frac{-V_S \omega RC}{2(1 + j\omega RC)} \\ &= \frac{V_S \omega RC}{2\sqrt{1 + (\omega RC)^2}} e^{j(\pi - \text{atan2}(\omega RC, 1))} \end{aligned}$$

Now, we can use the Inverse Phasor Transform formula:

$$\begin{aligned} v_{\text{out}}(t) &= \tilde{V}_o e^{j\omega t} + \overline{\tilde{V}_o} e^{-j\omega t} \\ &= 2|\tilde{V}_o| \cos(\omega t + \angle \tilde{V}_o) \\ &= \frac{V_S \omega RC}{\sqrt{1 + (\omega RC)^2}} \cos(\omega t + \pi - \text{atan2}(\omega RC, 1)). \end{aligned}$$

This formula might look complicated, but it'll become significantly simpler when we have actual values of R, C, ω to plug in. An example of this will be at the start of the next Note!

A Warning

Be aware that in this course phasors are defined slightly differently from how it is often done elsewhere. Essentially, there is a factor of 2 difference.

In this course, we define the phasor representation \tilde{X} of a sinusoid $x(t)$ to be such that

$$x(t) = \tilde{X} e^{j\omega t} + \overline{\tilde{X}} e^{-j\omega t}.$$

However, elsewhere, the phasor representation may be defined such that

$$x(t) = \frac{1}{2}(\tilde{X} e^{j\omega t} + \overline{\tilde{X}} e^{-j\omega t}).$$

Our definition is more natural and aligns to what you will see in later courses when you learn about Laplace and Fourier transforms. This is because our definition arises from the mathematics, and the same spirit of definition works even when working with inputs of the form e^{st} where s is not a purely imaginary number.

But then why would anyone ever use the alternative, more common definition? Its main advantage is that the magnitude of the phasor equals the amplitude of the signal. For instance, if we have the signal $A \cos(\omega t + \phi)$, then the alternative definition yields the phasor $A e^{j\phi}$, with magnitude A . In contrast, our definition yields the phasor $(A/2) e^{j\phi}$. The former definition is convenient when conducting physical observations - when using an oscilloscope, one can easily see⁴ the amplitude A of a signal, not the half-amplitude $A/2$.

Furthermore, it turns out that there are some slight calculation advantages (i.e. it makes some formulas simpler) to the more common definition when working with power systems and power electronics, which you may see if you take the relevant upper-division EE courses. However, for the purposes of the scope of this course, our definition is simpler and easier to understand, so we will stick with it throughout.

Of course, if the mathematics is done correctly, there is no real difference between the two definitions, in that both describe the same physical behaviors. It is just easier to do the mathematics correctly with the definition we use here.

Contributors:

- Neelesh Ramachandran.

⁴Actually in practice, if there is a DC component to the circuit — i.e. there are some inputs that are constants too — then the easiest thing to see is the peak-to-peak swing of the voltage which corresponds to twice the amplitude. So even the more common definition often forces the person using it to have to divide by two.

- Rahul Arya.
- Anant Sahai.
- Jaijeet Roychowdhury.