

## Lab 1: Introduction to S1XT33N

This semester, we will be building S1XT33N, a robot car that listens to voice commands and then drives on the command's pre-defined path. Before we dive into it, we will first explore the various lab equipment which will be crucial to building and debugging the car and circuits in general, then put together an op amp circuit to practice breadboarding and debugging. You will be implementing an inverting amplifier with an offset, as well as LEDs on the input and output nodes, and observing its behavior.

### Part 0: Ideal op-amp review

Recall the characteristics of the ideal op-amp:

- Infinite open-loop (i.e., not in feedback) voltage gain.  
 This is vital for Golden Rule I. It allows the amplifier to instantly correct a voltage difference of any magnitude between the input terminals.
- Infinite input impedance (the inputs act as ideal voltmeters)
- Zero output impedance (the output acts like an ideal voltage source)
- Infinite bandwidth  
 This liberates the op-amp's performance from dependence on frequency.
- Zero input offset voltage (i.e., for an input of 0V, the output will be exactly 0V)
- **Open-loop performance:** The open-loop (i.e., not in feedback) output voltage is given by

$$V_o = A(V^+ - V^-),$$

where  $A$  is the amplifier's open-loop gain.

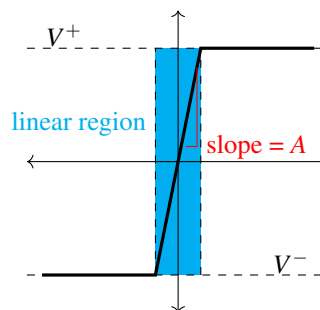

And, recall the Golden Rules for an ideal op-amp:

- (i)  $V^+ = V^-$ : When the op-amp is in negative feedback, the output attempts to do whatever is necessary to make the voltage difference between the inputs zero.

This doesn't mean that the op-amp actually directly changes the voltage at its inputs: that would be both impossible and inconsistent with golden rule II. It simply "looks" at the inputs and moves the output so that the input voltage differential goes to zero.

- (ii)  $I_{in}^+ = I_{in}^- = 0$ : The inputs draw no current.

Remember: Golden Rule (i) *only* applies when the op-amp is in negative feedback!

### Part 1: Op-Amp Buffer Circuit

You will be building an op-amp circuit for part 2 of this lab. Before discussing the specific op-amp circuit for this lab, we will start with a simpler op-amp circuit, a buffer circuit, then work our way up to an inverting amplifier with an offset. A buffer circuit takes the input signal and simply copies or replicates it on its output. One of the simplest ways to implement this is using an op-amp as configured below:

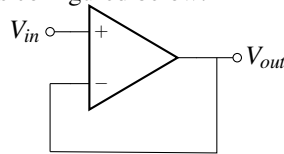

This is the main part of the circuit. To analyze how it works, we will apply our op-amp golden rules. In order for us to be able to apply Golden Rule (i), the op-amp must be configured in negative feedback. For this circuit, the op-amp is indeed in negative feedback (convince yourself why!) so we can apply Golden Rule (i) without any issues. So, we know that  $V^+ = V^-$ . From the circuit schematic, we can also see that  $V_{out} = V^-$  because of the wire connecting the two together. Therefore, we get that  $V_{out} = V^+ = V_{in}$ , proving that this circuit does indeed function as a buffer, and simply copies its input to its output.

### Part 1.5: Op Amps in Negative Feedback

Feedback is a basic concept in control systems that consists of comparing the actual output with the desired output and correcting the system accordingly. Negative feedback in amplifiers is usually implemented by using the output to cancel some of the input (e.g. by subtracting the output from the input). This (somewhat surprisingly<sup>1</sup>) linearizes the amplifier's performance and allows the overall circuit to become less dependent on component imperfections to the point of depending only on the properties of the feedback network itself. This is why most op-amps have very high (usually around a million) open-loop gain. To investigate negative feedback further, let's abstract away the circuit and model our system with a block diagram:

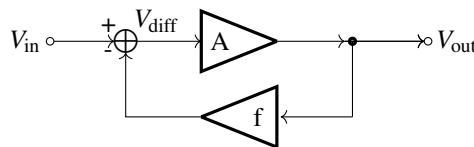

In this model, the amplifier has open-loop voltage gain  $A$ . In the feedback loop, the output voltage is multiplied by the feedback factor  $f$  and then subtracted from the input to yield  $V_{diff}$ . So,

$$V_{diff} = V_{in} - fV_{out},$$

and, as shown in the earlier discussion of open-loop performance,

$$V_{out} = AV_{diff}.$$

Substituting in  $V_{in} - fV_{out}$  for  $V_{diff}$  and rearranging yields

$$A(V_{in} - fV_{out}) = V_{out}$$

$$V_{out} = \frac{A}{1 + Af} V_{in}$$

and so the closed-loop voltage gain  $V_{out}/V_{in}$  is just

$$G = \frac{A}{1 + Af}$$

This is known as **Black's formula** for negative feedback, after Harold S. Black, who discovered its usefulness in 1928. For (ideally) infinite open-loop gain  $A$ ,  $G = 1/f$ .

<sup>1</sup>When Harold S. Black attempted to patent negative feedback, he quipped that his patent application "was treated in the same manner as one for a perpetual motion machine."<sup>[1]</sup>

We can now use this model to investigate the op-amp buffer. Let's see how this formula, driven from the abstract model above, is connected to the buffer that you will be building in this lab. Let us begin by assuming the open-loop gain  $A$  is not infinite so that we can later demonstrate what benefits infinite  $A$  brings.

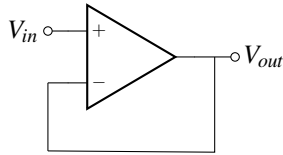

$$V_{out} = A(V_{in} - V^-), V^- = V_{out}$$

$$V_{out}(1 + A) = AV_{in}$$

$$V_{out} = V_{in} \frac{A}{1 + A}$$

$$V_{out} = V_{in} \frac{1}{\frac{1}{A} + 1}$$

We can see that for an infinite  $A$ ,  $\frac{V_{out}}{V_{in}}$  will simplify to 1, just like  $\frac{1}{f}$  in Black's formula for  $f=1$ .

As another example, we will use the same model to investigate another common op-amp circuit: the non-inverting amplifier. Again, let us begin by assuming the open-loop gain  $A$  is not infinite so that we can later demonstrate what benefits infinite  $A$  brings.

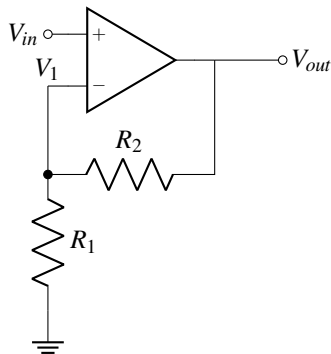

$$V_{out} = A(V_{in} - V_1), V_1 = \frac{R_1}{R_1 + R_2} V_{out}$$

$$V_{out}(1 + A \frac{R_1}{R_1 + R_2}) = AV_{in}$$

$$V_{out} = V_{in} \frac{A}{1 + A \frac{R_1}{R_1 + R_2}}$$

$$V_{out} = V_{in} \frac{1}{\frac{1}{A} + \frac{R_1}{R_1 + R_2}}$$

We can see that for an infinite  $A$ , the gain  $\frac{V_{out}}{V_{in}}$  will simplify to  $(1 + \frac{R_2}{R_1})$ , just like  $\frac{1}{f}$  in Black's formula for  $f = \frac{R_1}{R_1 + R_2}$ . Another interesting observation is that for infinite  $A$ ,  $V_1$  will be equal to  $V_{in}$  (Golden rule "i").

**Brief Aside: Resistive Divider Review**

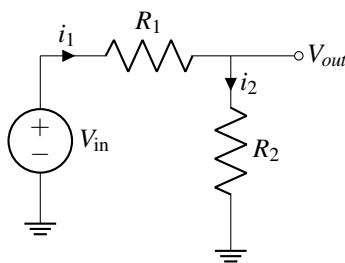

$$i_2 = \frac{V_{out}}{R_2}, i_1 = \frac{V_{in} - V_{out}}{R_1}$$

$$i_1 = i_2$$

$$\frac{V_{in} - V_{out}}{R_1} = \frac{V_{out}}{R_2}$$

$$\frac{V_{in}}{R_1} = V_{out}(\frac{1}{R_1} + \frac{1}{R_2}) = V_{out}(\frac{R_1 + R_2}{R_1 R_2})$$

$$V_{out} = \frac{R_2}{R_1 + R_2} V_{in}$$

**Part 2: Adding a reference voltage to op-amp circuits**

In many applications, we do not have access to a signal centered at 0V because negative voltages cannot be output. For example, in many microcontrollers like the Arduino Leonardo we use in class, the pins cannot output negative voltages, nor can they tolerate them as inputs either. Therefore, the signals they output are shifted upwards in voltage, also called a DC offset, centered at a positive voltage. If we try to amplify this shifted signal (e.g. a sinusoid centered at 1.65V), we will end up amplifying this offset (the 1.65V) along with the actual signal (the sinusoid) itself, as the op-amp does not distinguish between the offset and the signal when amplifying. Meanwhile, we only really want to

amplify the signal by itself while preserving the same DC offset at the output (e.g. an input sinusoid with an amplitude of 1V centered at 2V to an output sinusoid with an amplitude of 2V also centered at 2V). To do this, we can introduce a reference voltage, or a “virtual ground”, to the amplifier that it will reference when amplifying its input signal, effectively ignoring the DC offset in the input while preserving its magnitude at the output. We will discuss here how to set a reference voltage for inverting and noninverting amplifiers.

Let’s start with the inverting amplifier:

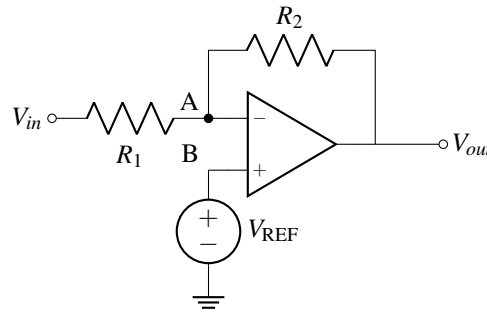

From the first golden rule, we know the fact that node B is at  $V_{REF}$  means that node A is as well. From the second, we have the equation

$$\frac{V_{out} - V_{REF}}{R_2} = \frac{V_{REF} - V_{in}}{R_1}$$

Let’s perform a change of coordinates. Let  $V_{in}^* = V_{in} - V_{REF}$  and let  $V_{out}^* = V_{out} - V_{REF}$ . Then, we have

$$\frac{V_{out}^*}{R_2} = \frac{-V_{in}^*}{R_1}$$

$$\frac{V_{out}^*}{V_{in}^*} = \frac{V_{out} - V_{REF}}{V_{in} - V_{REF}} = -\frac{R_2}{R_1}$$

Therefore, we’re amplifying the difference between  $V_{in}$  and  $V_{REF}$  with respect to the difference between  $V_{out}$  and  $V_{REF}$ , which is what we wanted to achieve: we have essentially set the “virtual ground” for the amplifier to  $V_{REF}$ . If we set our  $V_{REF}$  to be equal to the DC offset of our input signal, we will have successfully amplified our signal while preserving the same offset at the output.

The process for the noninverting amplifier is similar.

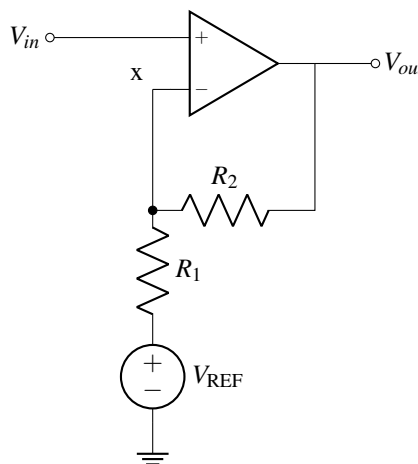

From the first golden rule, we know  $V_x = V_{in}$ , so we can write

$$\frac{V_{out} - V_{in}}{R_2} = \frac{V_{in} - V_{REF}}{R_1}$$

Now, we'll perform the same change of coordinates: letting  $V_{in^*} = V_{in} - V_{REF}$  and let  $V_{out^*} = V_{out} - V_{REF}$ , we have

$$\frac{V_{out^*} + V_{REF} - V_{in}}{R_2} = \frac{V_{in^*}}{R_1}$$

Substituting  $-V_{in^*}$  for  $V_{REF} - V_{in}$ , we have

$$\begin{aligned} \frac{V_{out^*} - V_{in^*}}{R_2} &= \frac{V_{in^*}}{R_1} \\ \frac{V_{out^*}}{R_2} &= V_{in^*} \left( \frac{1}{R_1} + \frac{1}{R_2} \right) \\ \frac{V_{out^*}}{V_{in^*}} &= 1 + \frac{R_2}{R_1} \end{aligned}$$

So, once again, we set the amplifier's virtual ground to  $V_{REF}$  in order to amplify the difference between  $V_{in}$  and  $V_{REF}$  with respect to the difference between  $V_{out}$  and  $V_{REF}$ . If we set our  $V_{REF}$  to be equal to the DC offset of our input signal, we will have successfully amplified our signal while preserving the same offset at the output.

### Part 2.5: Measuring gain of op-amp circuits

In all of the circuits we have analyzed above, we found the gain formula using theoretical equations, assuming that the op-amps and circuit components we have are perfect. In reality, our components and op-amps have non-idealities that make the gain that we measure different from the gain calculated from the theoretical formula. In order to measure the gain  $A_v$ , we use the following formula, using the measured input and output values:

$$A_v = \frac{\Delta V_{out}}{\Delta V_{in}} = \frac{V_{out}|_{V_{in}=V_{in,max}} - V_{out}|_{V_{in}=V_{in,min}}}{V_{in,max} - V_{in,min}}$$

where  $V_{out}|_x$  means  $V_{out}$  given the condition  $x$ . For example,  $V_{out}|_{V_{in}=V_{in,max}}$  means the output voltage of the op-amp when the input voltage is at its maximum. For this lab, we care about the **measured** gain, not the theoretically calculated gain, so make sure to use this formula that involves measuring the input and output voltages for your answers to the questions.

## Appendix A: EECS16A Circuits Cookbook

(For Reference: Example Circuits)

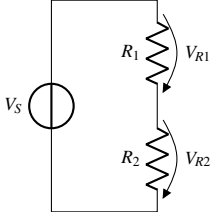
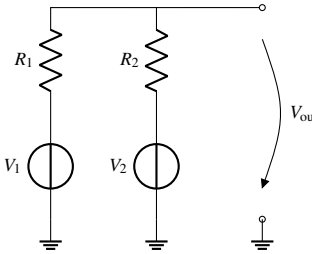
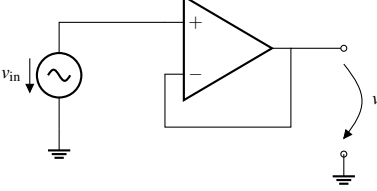
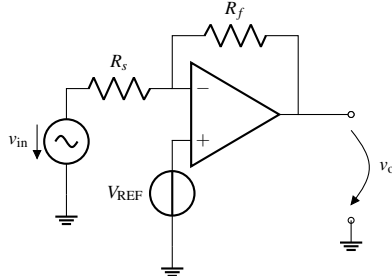
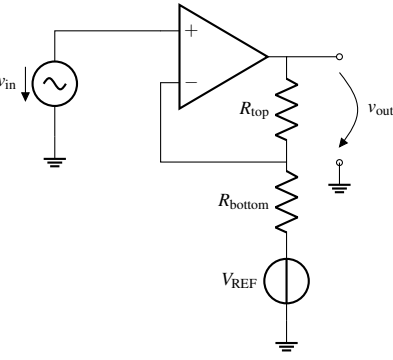
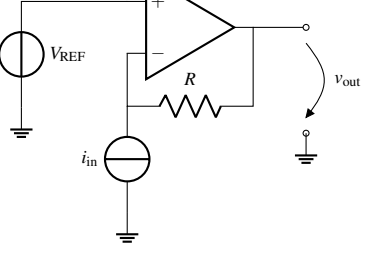
<p style="text-align: center;">Voltage Divider</p>  $V_{R2} = V_S \left( \frac{R_2}{R_1 + R_2} \right)$	<p style="text-align: center;">Voltage Summer</p>  $V_{out} = V_1 \left( \frac{R_2}{R_1 + R_2} \right) + V_2 \left( \frac{R_1}{R_1 + R_2} \right)$	<p style="text-align: center;">Unity Gain Buffer</p>  $\frac{v_{out}}{v_{in}} = 1$
<p style="text-align: center;">Inverting Amplifier</p>  $v_{out} = v_{in} \left( -\frac{R_f}{R_s} \right) + V_{REF} \left( \frac{R_f}{R_s} + 1 \right)$	<p style="text-align: center;">Non-inverting Amplifier</p>  $v_{out} = v_{in} \left( 1 + \frac{R_{top}}{R_{bottom}} \right) - V_{REF} \left( \frac{R_{top}}{R_{bottom}} \right)$	<p style="text-align: center;">Transresistance Amplifier</p>  $v_{out} = i_{in}(-R) + V_{REF}$

## Works Cited

Horowitz, P. and Hill, W. (2016). The Art of Electronics. 3rd ed. Cambridge: Cambridge University Press, p.115-120  
Sedra, Adel S., and Smith, Kenneth C. Microelectronic Circuits. 7th ed. New York: Holt, Rinehart and Winston, 1982  
<https://www.electronics-tutorials.ws/wp-content/uploads/2018/05/resistor-res5.gif>  
<https://www.bragitoff.com/wp-content/uploads/2015/09/CapacitorsCheatSheet.png>

*Written by Mia Mirkovic (2019), v0.2 (2020)*  
*Edited by Hossein Najafi (2021), v0.3 (2021)*  
*Edited by Rafael Calleja (2021), v0.4 (2021)*  
*Edited by Steven Lu (2021), v0.5 (2021), v0.6 (2022)*  
*Edited by Megan Zeng (2022)*  
*Edited by Jessica Fan (2023)*