

PROBLEM SET #1

Issued: Tuesday, Aug.30, 2011

Due (at 7 p.m.): Tuesday, Sept. 13, 2011, in the EE C245 HW box in 240 Cory.

This homework assignment is intended to give you some early practice playing with dimensions and exploring how scaling can greatly improve certain performance characteristics of mechanical systems. Don't worry at this point if you do not understand fully some of the physical expressions used. Some of them will be revisited later in the semester.

1. One of the most commercially successful MEMS products to date is the MEMS accelerometer, with applications ranging from air-bag deployment sensors to movement sensors for smartphones and the Nintendo Wii. This question will explore how the benefits of scaling have contributed to this commercial success. If you need a primer on the basics of how an accelerometer works, consult G. Kovacs, *Micromachined Transducers Sourcebook*, pp. 226-229, covering "Basic Accelerometer Concepts".

For the purposes of this question, the following devices should be used as a reference "macro-scale" accelerometer and a reference MEMS accelerometer (the relevant data sheets may also be found on the course website):

- "Macro" Accelerometer: Model 622B01 Precision Industrial ICP® Accelerometer: http://www.pcb.com/contentstore/docs/PCB_Corporate/IMI/products/Manuals/622B01.pdf
- MEMS Accelerometer: ADXL326: Small, Low Power, 3-Axis ± 16 g Accelerometer: <http://www.analog.com/en/mems-sensors/inertial-sensors/adxl326/products/product.html>

- (a) There are several key parameters that gauge accelerometer performance. **Sensitivity** is a measure of the minimum detectable signal. **Bandwidth** tells the range of vibration frequencies to which the accelerometer responds. **Range** is a measure of the maximum detectable signal. Fill out the table below for both the "Macro" and MEMS accelerometers. [Note: Since the "Macro" accelerometer measures along only one axis, while the MEMS accelerometer measures over 3 axes, so you may use the data from the best-performing axis for the MEMS accelerometer entries.] (3 %)

	Sensitivity	Bandwidth (3 dB)	Range
"Macro" Accelerometer			
MEMS Accelerometer			

- (b) There are also some secondary parameters for accelerometer performance. **Shock Survival** is a measure of the maximum acceleration the accelerometer can withstand without breaking. **Power** tells the minimum power consumption required to operate the device. Fill out the table below for both the “Macro” and MEMS accelerometers. (2%)

	Shock Survival	Power
“Macro” Accelerometer		
MEMS Accelerometer		

- (c) For each category listed in the above tables, state which type of accelerometer has the better performance and explain based on the physical difference in size between the two devices. Include equations in your explanation, as necessary [Hint: Read Senturia chapter 19.2] (25 %)
- (d) For the vast majority of accelerometer applications, the single most important parameter is **Cost**. For example, for air-bag deployment sensors (2 billion of which are sold per year) sensitivity and bandwidth have little impact on system-level performance; however, as with all elements of automobile manufacture, keeping the costs as low as possible is imperative. In large volumes (>10,000 units), the cost of the “Macro” scale accelerometer is ~\$100/axis. From the Analog Devices website, find the cost-per-axis of the ADXL326 MEMS accelerometer. Besides (much) lower cost, what are two other factors that have led to the wide-spread commercial adoption of MEMS accelerometers, compared with their macro-scale counterparts? (10 %)
2. The die size for the ADXL326 in the previous question is approximately 4mm x 4mm. Assume that the MEMS devices for the ADXL326 are fabricated atop a finished 12 inch circular CMOS wafer containing all the necessary output measurement circuits.
- (a) Assume the useful area of the wafer is the largest possible square which fits inside the wafer circle (the edges being used for wafer handling). Further assume that the dicing saw used to dice the individual dies from the wafer has a cut width of 50 μm . What is the maximum number of 4mm x 4mm ADXL326 dies produced by one wafer? (5 %)
- (b) If the die size of the ADXL326 can be decreased to 3mm x 3mm through scaling, what is the new maximum number of ADXL326 dies produced by one wafer? Qualitatively speaking, what are the consequences for this, in terms of final device cost? (5 %)
- (c) The proof mass for the ADXL326 accelerometer consists of a rigid plate supported on each end by flexible springs. In order for the accelerometer to function correctly, there

is a maximum allowable compressive stress across the plate, beyond which the plate buckles and the accelerometer no longer functions. This critical value of stress is called the *Euler buckling limit*, and is given in Senturia Chapter 9.6:

$$\sigma_{Euler} = -\frac{\pi^2}{3} \frac{EH^2}{L^2}$$

where H is the thickness of the plate, L is the length of the plate, and E is the Young's Modulus of the plate material. Assume that the proof mass for each accelerometer axis is a polysilicon plate with a width of $100\mu\text{m}$, a length of $500\mu\text{m}$, and a thickness of $2\mu\text{m}$: (10 %)

- i. What is the critical stress along the length of the proof mass plate at which the plate buckles (assume E of 160 GPa)?
- ii. The stress in the plate for any given die in the wafer follows a Gaussian distribution, with a mean of zero and a standard deviation of 5 MPa. Assuming that this is the primary contributing factor to variability in the devices, what is the device yield percentage on the 12 inch wafer?
- iii. Imagine Analog Devices has improved its measurement circuit such that they can now scale their proof masses down to have a width of $50\mu\text{m}$, a length of $300\mu\text{m}$, and a thickness of $2\mu\text{m}$. What is the new yield, assuming the same stress distribution as before?

3. Suppose a step-function voltage V_A were suddenly applied across the outer anchors of a $2\mu\text{m}$ thick fixed-fixed polysilicon structure comprised of beams and proof mass structures, as shown in Figures 1 and 2, which also provide lateral dimensions. For polysilicon, assume the following material properties: Young's modulus $E = 150\text{ GPa}$, density $\rho = 2,300\text{ kg/m}^3$, Poisson ratio $\nu = 0.226$, sheet resistance = $10\ \Omega/\square$, specific heat = $0.77\text{ J/(g}\cdot\text{K)}$, and thermal conductivity = $30\text{ W/(m}\cdot\text{K)}$. Also assume the initial temperature of the structure is $20\text{ }^\circ\text{C}$.
- With what time constant will Proof Mass A reach its steady-state temperature after the voltage V_A steps from 0V to 1V ? Give a formula and a numerical answer with units (10%)
 - If the final step function value of V_A is 1V , what is the steady-state temperature of Proof Mass A? Give a formula and a numerical answer with units (15%)
 - If the final step function value of V_A is 1V , what is the steady-state temperature of Proof Mass B? Give a formula and a numerical answer with units (15%)

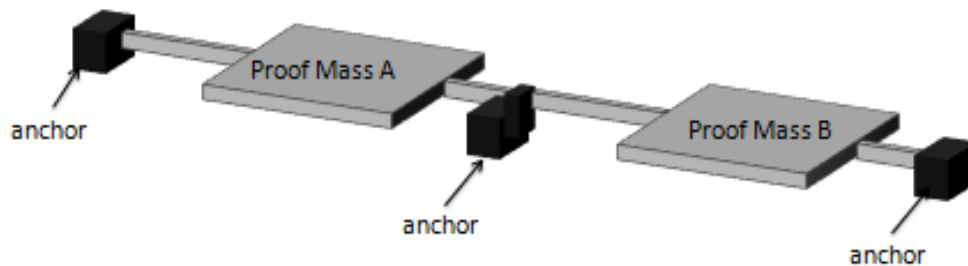

Figure 1

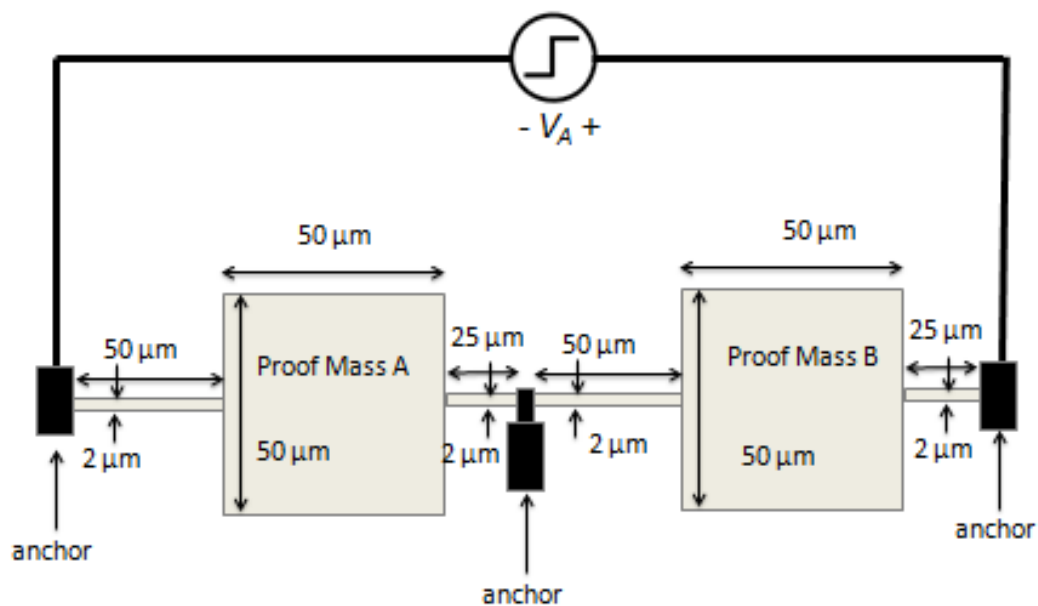

Figure 2