

UNIVERSITY OF CALIFORNIA, BERKELEY

EE40: Introduction to Microelectronic Circuits Lab 1

Introduction to Circuits and Instruments Guide

1. Objectives

The electronic circuit is the basis for all branches of electrical engineering. In this lab, basic electronic circuit theory, electronic and photonic devices will be introduced and employed. Fundamental testing equipment will be used to measure and characterize simple circuitry. In the hands-on lab, you will apply these basic theories to the devices and components provided to design simple circuits.

2. Basic circuit theory and devices

In this section, some basic circuit theory will be presented first. You will need to apply this to the following hands-on lab to design your circuit. Simple electronic and photonic devices such as resistors, light emitting diodes (LEDs) and speakers/microphones will also be discussed and used in the lab. Before doing the lab, please read through this section carefully and complete the prelab to test your understanding of the material presented here.

(1) Ohm's Law: $V = IR$

Current (denoted I) and voltage (denoted V) are two major quantities that are used to study electronic circuits. Current is the amount of charge passing through a certain area in a unit time period, while voltage describes the electrical potential drop across any two nodes in a given circuit. Ohm's Law states that the voltage V across an ideal resistor is proportional to the current I through the resistor. The constant of proportionality is the resistance R of the resistor.

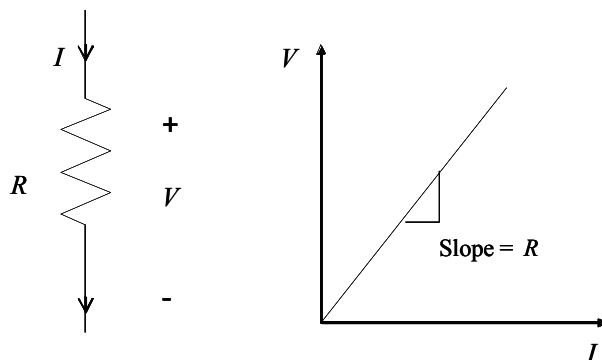

Figure 1

(2) Series and parallel connections

A circuit usually contains many devices connected in different fashions. Two basic

types of configuration are series and parallel.

As shown in the figure below, when the devices are connected in series, the current going through them is the same ($I = I_1 = I_2$), and the total voltage across both devices is the sum of the voltage across each device ($V = V_1 + V_2$). However, for parallel connection, the voltage across the devices is the same ($V = V_1 = V_2$) since they share the same nodes across which the potential drop is measured, and the total current running through all the devices is the sum of the current in each branch ($I = I_1 + I_2$).

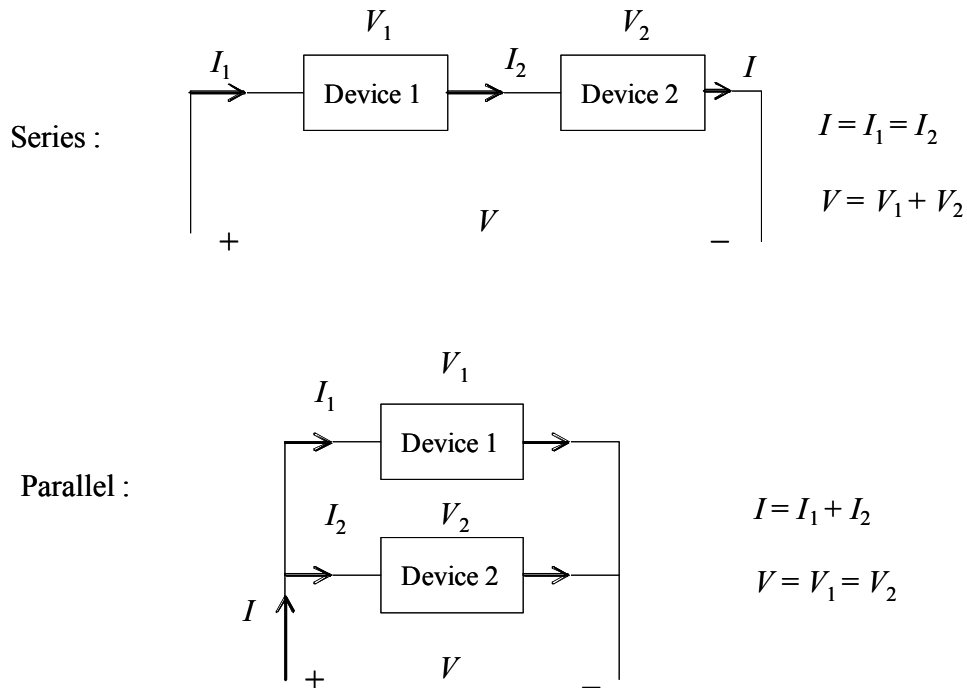

Figure 2

Now let us examine the resistive circuits shown below.

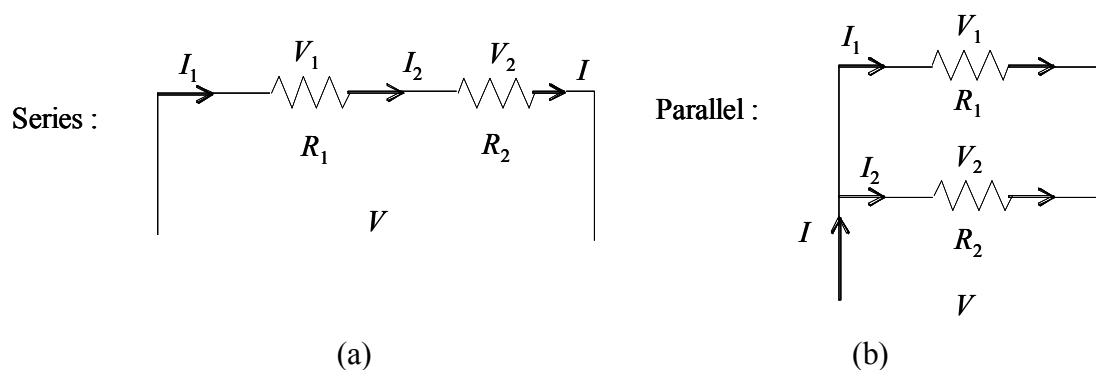

Figure 3

In (a), based on Ohm's law, $V_1 = R_1 I_1$, $V_2 = R_2 I_2$

And since this is a series connection, $I_1 = I_2 = I$, $V = V_1 + V_2$

Therefore, $V = (R_1 + R_2) I$

Voltage-divider circuit:

It is straightforward to get $V_1 = \frac{R_1}{R_1 + R_2}V$ and $V_2 = \frac{R_2}{R_1 + R_2}V$.

Therefore, when a voltage is applied to a series combination of resistances, a fraction of the voltage appears across each of the resistances. And of the total voltage, the fraction that appears across a given resistance in a series circuit is the ratio of the given resistance to the total series resistance.

In (b), the two resistors are connected in parallel.

From Ohm's law, $V_1 = R_1I_1$, $V_2 = R_2I_2$

And since this is a parallel connection, $V_1 = V_2 = V$, $I = I_1 + I_2$

Therefore, $I = V/R_1 + V/R_2 = R_1R_2V/(R_1 + R_2)$

Current-divider circuit:

It is straightforward to get $I_1 = \frac{R_2}{R_1 + R_2}I$ and $I_2 = \frac{R_1}{R_1 + R_2}I$

Therefore, the total current flowing into a parallel combination of resistances divides, and a fraction of the total current flows through each resistance. And the fraction of the total current flowing in a resistor is the ratio of the *other* resistance to the sum of the two resistances.

(3) Ideal voltage and current sources

An ideal voltage source supplies a constant voltage across its output terminals no matter how much current is going through it. Likewise, an ideal current source will supply constant current out no matter what the voltage across it is. The circuit symbol of the ideal voltage or current source is shown in the figure below.

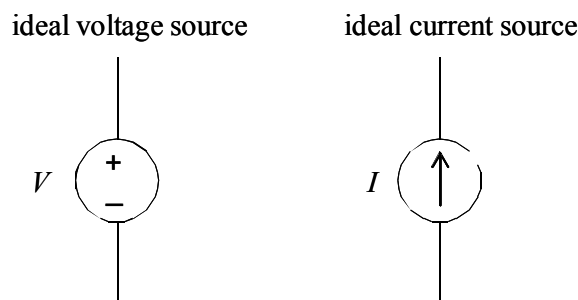

Figure 4

(4) Resistor

The resistor is the most basic and widely used component in electronic circuits. And the relation of the voltage and the current of a resistor in a circuit will follow Ohm's law. A typical resistor is color coded to indicate the resistance value.

There are two types of color coding, 4-band-code and 5-band-code. As can be seen, the 5-band-code has one more digit resolution than the 4-band-code.

The following chart provides the color code for both 4-band and 5-band resistors. To decode the color bands and calculate the corresponding resistance value, one needs to follow the steps below.

- Find the tolerance band. It is located at one end of the resistor and far away from the rest of the color bands. It gives the accuracy of the actual resistance to the value that is labeled.
- Start from the other end and use the color code map to identify the color band. This will be the first digit (the most significant digit) of the resistance value.
- Then similarly decode the second and the third band (for 5-band resistor only). Write down all the digits in order (from left to right).
- The last band is the multiplier. Use the decoded digits to multiply the decoded multiplier to get the resistance value.

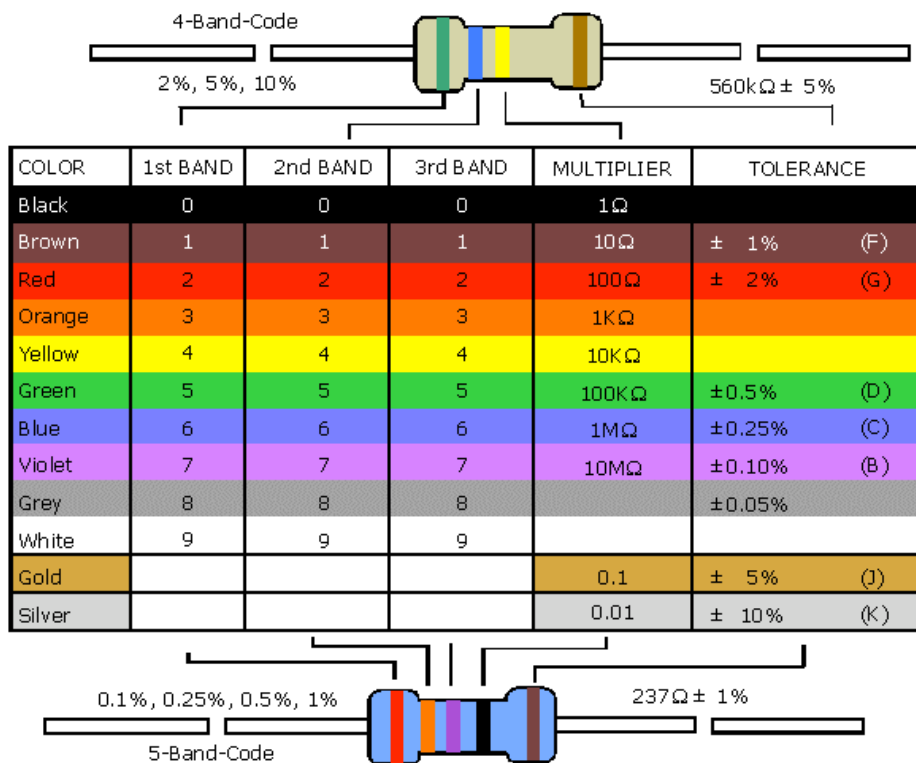

(5) Light emitting diode (LED)

A diode is a basic but very important device that has two terminals, the anode and the cathode. Current can ONLY flow from anode to cathode, and NOT the other way around. The circuit symbol for a diode is shown in the (a) figure below, indicating the polarity. The simple piecewise-linear model approximates a diode's I-V characteristic and is shown in (b). When the voltage applied across the diode is higher than a certain threshold value V_{TH} , the diode is on, and the voltage across it stays fixed at the threshold value. However, if the voltage is lower than V_{TH} , the diode is off, and there is no current going through the device. The actual diode I-V characteristic is shown in (c).

Even though it does not have a sharp turn-on at a well defined threshold voltage, the simple piecewise-linear model is still a good approximation in most applications. A light emitting diode is a diode that will emit light when it is on. The color of the light depends on the material used to fabricate the device.

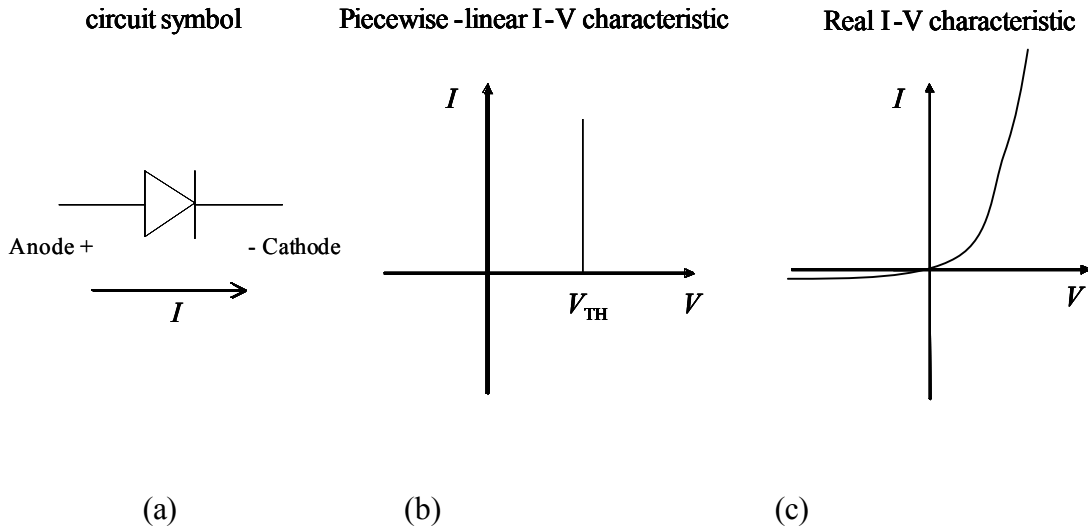

Figure 5

The polarity of an LED device is often denoted by the length the two legs. For example, the LED that will be used in this lab is shown in the figure below. The long leg is the anode, while the short leg is the cathode.

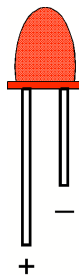

Figure 6

(6) Speaker/Microphone

A speaker is a device which converts an electrical signal into mechanical vibration of a membrane, which creates sound waves. A sound's pitch is measured by the frequency of the wave. A single frequency sinusoidal signal (Sine wave) will generate a monotone. High frequency signals results in high pitch and vice versa.

A microphone is essentially the reverse of a speaker. Sound information exists as patterns of air pressure which changes the membrane mechanically, thus transferring it into electrical signal.

3. Introduction to major equipment

(1) Breadboard

A breadboard is a reusable solderless device used to build a (generally temporary) prototype of an electronic circuit and for experimenting with circuit designs. This is in contrast to stripboard (veroboard) and similar prototyping printed circuit boards (PCB), which are used to build more permanent prototypes or one-offs, and cannot easily be reused. A typical breadboard will have strips of interconnected electrical terminals, known as bus strips, down one or both sides—either as part of the main unit or as separate blocks clipped on—to carry the power rails.

A typical breadboard with a circuit built on it is shown below.

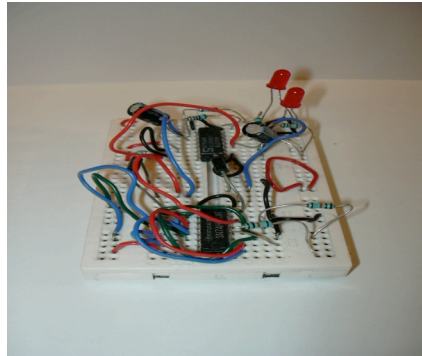

Figure 7. A breadboard with a completed circuit

A modern solderless breadboard consists of a perforated block of plastic with numerous tin plated phosphor bronze spring clips under the perforations. Integrated circuits (ICs) in dual in-line packages (DIPs) can be inserted to straddle the centerline of the block. Interconnecting wires and the leads of discrete components (such as capacitors, resistors, inductors, etc.) can be inserted into the remaining free holes to complete the circuit topology. In this manner, a variety of electronic systems may be prototyped, from small circuits to complete central processing units (CPUs). However, due to large stray capacitance (from 2-25pF per contact point), solderless breadboards are limited to operating at relatively low frequencies, usually less than 10 MHz, depending on the nature of the circuit. The node connection of a typical breadboard is shown in the figure.

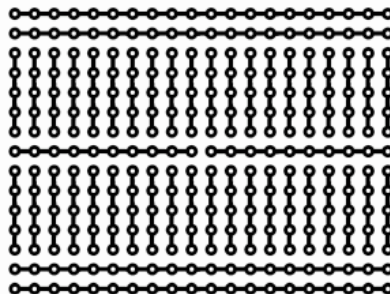

Figure 8. The node connection of a typical breadboard

(2) Power supply

Like a battery, a DC power supply provides a constant voltage for powering electronic

circuits. But, unlike a battery, the power supply won't die out. It will provide continuous power as long as it is connected to a wall outlet. Furthermore, you can set the voltage of the supply as needed and set the maximum current (the current limit feature) that can be drawn from it. The power supply will NOT output a value of current greater than the set limit. If the circuit is operated in a situation that it needs to draw more current than the set maximum current, the supply will adjust the output voltage to match this maximum value of current. This feature will protect the circuit when you know beforehand that it cannot tolerate more than a certain current level.

In this lab, we use HP E3631A triple output DC power supply. The figure below shows the front panel of the HP E3631A power supply. The shaded switches will not be used in this lab. These switches control the more advanced features built into the equipment. Consult the User's Manual for more information. The power supply contains three variable voltage sources, with maximum voltage values of +6V, +25V, and -25V. The 6V supply operates independently. The +25V and -25V supplies share a common reference terminal (com). The earth ground is the terminal connected to the case of the instrument and more importantly, the earth, through the building wall socket.

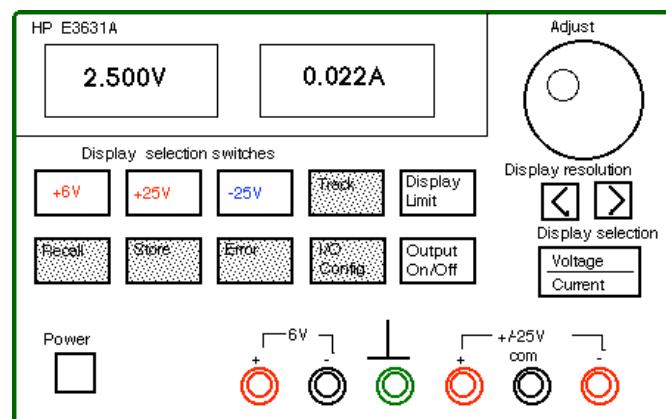

Figure 9

The concept of “ground” is **VERY IMPORTANT**. A ground node means the potential at that node is 0 volts. Since voltage is the potential difference between two nodes, “5 volts” means one node has a potential of 5 volts with respect to a ground (or a reference) node. In the figure above, the true ground – earth ground is the green connector, but all other black connectors are reference grounds that can be used to apply voltage to a circuit.

Figure (a) below illustrates symbolically the connection of the power supply. Note that the earth ground terminal is isolated and is connected to the case of the instrument, which is also connected to the earth ground through the 3-wire receptacle. The +25V and -25V supplies outputs have a common output terminal (denoted by "com") which is isolated from the earth ground. The positive or negative terminals of each output can be grounded or each output can be left floating with respect to the ground.

A circuit schematic of the power supply is shown below. This should help you connect the power supply nodes to the circuit.

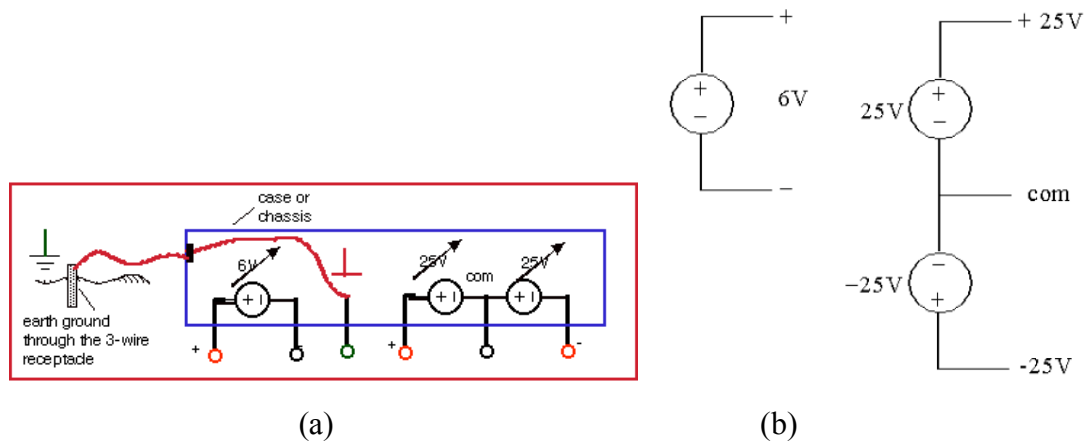

Figure 10

Please use the following steps to set a voltage output on the power supply:

- Make sure the power supply is disconnected from a circuit first and then turn it on.
- Make sure that the supply's output is off. This can be toggled by hitting the **Output On/Off** key. The display will display **OUTPUT OFF** when it is off.
- Select which source you would like to set, the **+25V**, the **-25V** or the **+6V** by pressing the corresponding key on the supply. The supply you have selected will be displayed along the bottom of the display screen.
- To set either the voltage or the current limit, press the **Display Limit** key. **LMT** will be shown at the bottom of the display indicating the limit will be changed. Use the knob on the right to set the value of the voltage needed.
- Select to set the voltage value or the current limit by pressing the **Voltage/Current** key below the knob on the right. The one that is blinking is the one that is being modified. Then the value of the limit can be changed by rotating the knob on the top right corner. To change the digit that you want to edit, use the left or right arrow keys.
- When done setting the limits, press the **Display Limit** key again to return to displaying the actual output voltage set before.
- Turn the output on once the supply is connected to the circuit.

The output signal will be delivered to the circuit through cables with either banana type of connectors or alligator clip type of connectors. The color convention is: red for positive signal and black for negative signal. Please follow this convention when you perform any measurement in the lab.

(3) Digital multimeter (DMM)

Currents and voltages are the basic circuit variables of interest. In this lab we are mainly concerned with accurately measuring resistance, DC voltage and currents using a digital multimeter (DMM). We will use the HP34401A digital multimeter which is a high performance instrument capable of measuring resistance, DC and AC voltage and current, as well as frequency. The HP34401A has a built-in microprocessor, memory and other electronics components that give it numerous features.

The following figure shows the circuit setup for resistance, voltage and current measurements. The principle of each measurement is explained below.

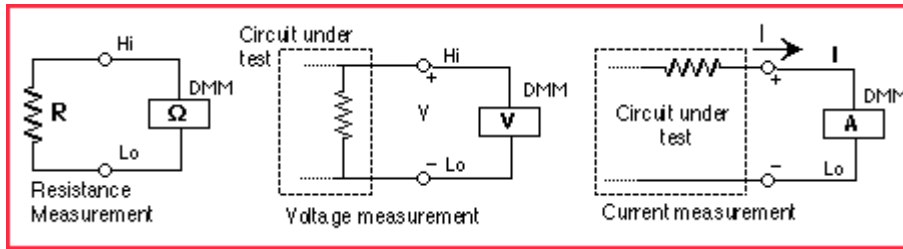

Figure 11

Resistance measurement (Ohmmeter)

The DMM measures a resistance by applying a known DC voltage over unknown resistance in series with a small resistance R_m . It measures the voltage over the resistance R_m and then calculates the unknown resistance R based on the formula shown in the figure (a) below.

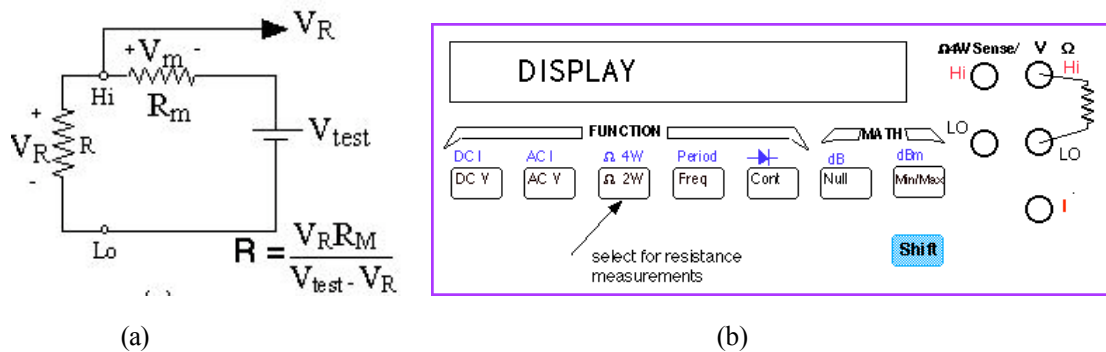

Figure 12

To use the DMM for resistance measurements, connect the two legs of the resistor to the terminals labeled **HI** (V a) and **LO** on the top right of the front panel, select the resistance measurement function by pushing the [**Ω 2W**] button (one of the function keys) on the front panel as shown below in the above figure (b). Notice that the selection keys are annotated in black and blue. To select the function in blue, you must first select the blue **Shift** key on the bottom right.

Voltage measurement (Voltmeter)

A DC voltage is measured by using a voltage amplifier and an analog-to-digital converter (ADC) inside the DMM as schematically shown in the figure below. A microprocessor further manipulates the data to give an accurate measurement for display.

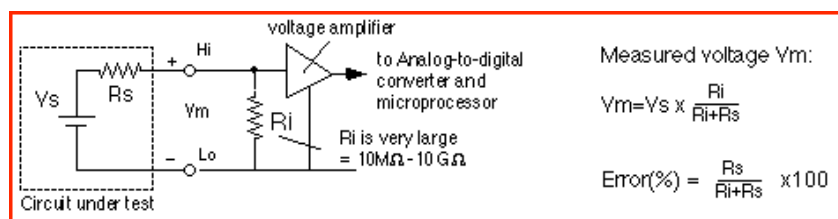

Figure 13

To measure a voltage, connect the nodes across which one wants to measure the voltage to the **HI** and **LO** input terminals of the DMM. In order to activate the DMM for DC measurements you have to select the DC voltage function by pushing the **DC V** button on the front panel. The measured value then will be displayed on the display panel.

Current measurement (Ammeter)

A DMM used as an ammeter senses the current flowing through its input terminals. The DMM must be connected in series with the circuit such the same current flows through the DMM and the test circuit (this usually requires the breaking open of the path of the circuit along with the current is going to be measured). The principle of the current measurement is quite simple. The ammeter has a very small resistance at its input terminals and measures the voltage that the test current generates over this resistance as shown in the figure below. The microprocessor then calculates the current, $I = V/r_i$, according to Ohm's law.

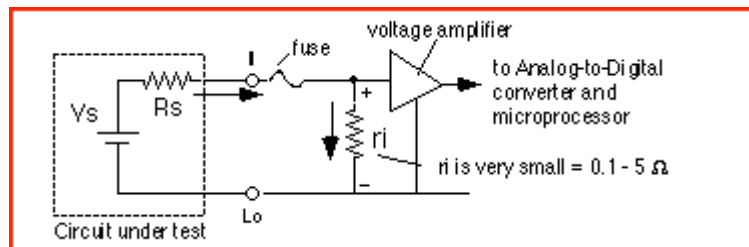

Figure 14

To use the DMM as an ammeter, one connects the leads in which the current flows to the current **I** and **LO** terminals. To activate the ammeter (DC current measurement) function, one must also select the **DC I** key by pushing **Shift** and then **DC V** button as previously shown in the figure of the instrument front panel.

(4) Function generator

A function generator is an instrument that can generate a periodic AC signal at different frequencies. In this lab, we use the HP 33120A function generator. This is a versatile instrument capable of generating sine, square, and other waveforms with frequencies up to 15 MHz. The amplitude and offset of these waveforms can also be controlled easily. The front panel of the function generator is shown in the figure below. A time-varying periodic voltage signal will be generated and output at the **OUTPUT** connector. By pushing the appropriate buttons on the front panel, the user can specify the following characteristics of the signal:

- Shape: sinusoidal, square, or triangular waves. These are all mathematical functions of time.
- Frequency: inverse of the period of the signal; units are cycles per second (Hz).
- Amplitude: peak to peak value of the time-varying component of the signal.
- DC Offset: constant voltage added to the signal to increase or decrease its mean or average level.

A sine wave of frequency f , peak to peak amplitude V_{pp} , and DC offset V_{DC} is written mathematically as $v(t) = (V_{pp}/2) \times \sin(2\pi f t) + V_{DC}$

When the function generator is turned on, the default output is a Sine wave at 1 kHz with peak to peak amplitude of 100 mV.

To set a specific signal with desired characteristics, please follow the steps below.

- a. To choose the waveform of the signal, press the key on the front panel labeled with the corresponding waveform
- b. Enable the frequency editing mode by pressing the **Freq** button.
- c. To set the value of the desired frequency you can press the keys with left right arrows to change the digit you want edit and turn the knob to change the value of each digit. Then set the unit by pressing the keys with up and down arrows.
- d. To set a DC offset, press the **Offset** button. Then again use the arrow keys to change the digit to be edited. And use the knob to change the value of each digit. The +/- button toggles the DC offset from a positive to a negative value.
- e. It is tricky to set up the signal amplitude because there is an internal 50 Ω resistor R_S in series with the oscillating voltage source. Therefore, if you connect the function generator to an external resistor R_L (or a circuit has an equivalent input resistance of R_L), it will form a voltage divider with R_S , and the displayed V_{pp} value will not be the actual signal value applied to R_L . The purpose of R_S is to have impedance matching which is important for high frequency circuits. The front panel display assumes the impedance matching condition, which is $R_S = R_L$ and always displays a value half of the actual voltage source output. Therefore, if the load resistance R_L is not equal to R_S , the displayed V_{pp} value is not the same as the signal amplitude on R_L . So the value of V_{pp} to be set on the signal generator needs to be calculated based on the voltage divider circuit formed by R_S and the load resistance R_L to get an appropriate desired V_{pp} on the load.

To set a peak-to-peak amplitude value, press the **Ampl** button. Use the arrow key to change the digit and the knob to change the value.

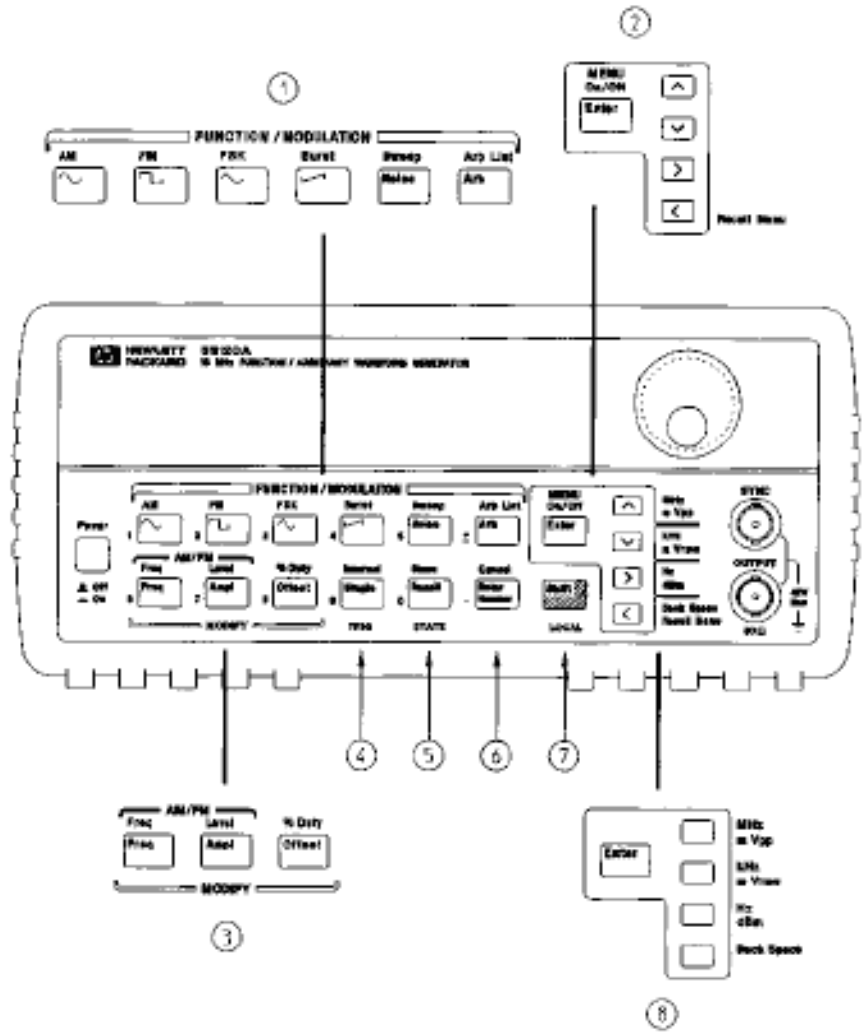

- | | |
|---|---------------------------------------|
| 1 Function / Modulation keys | 5 Recall / Store instrument state key |
| 2 Menu operation keys | 6 Enter Number key |
| 3 Waveform modify keys | 7 Shift / Local key |
| 4 Single / Internal Trigger key
(Burst and Sweep only) | 8 Enter Number "units" keys |

Figure 15

(5) Oscilloscope

An oscilloscope is a device that graphs voltage versus time. The display shows voltage on the vertical axis as a function of time on the horizontal axis. The user can control the scale of both the time and the voltage axes.

The HP54645D oscilloscope used in this lab can accept two voltage-signal inputs (A1 and A2 connectors) and graph them simultaneously but independently.

To measure the signal at any node of a circuit, a BNC cable with two alligator clips will be used. The red alligator is the signal hook and the black alligator is the ground clip. It is very important to connect the ground clip first to the circuit ground. Only when the oscilloscope and the circuit share the same ground (voltage reference), the measured signal is stable and accurate.

To measure a signal accurately, first press **A1** (if your cable is connected to A1 channel),

and then press the key below the **probe** menu on the bottom right of the screen until the highlighted number is **Auto 1**. To display a voltage pattern properly, press **Auto-scale** key. The oscilloscope will perform the measurement automatically. To get the measured number, for example, the peak-to-peak or average value of the signal, press **Voltage** on the top left and select the proper measurement shown on the screen. Ground (zero) level together with the channel number will be indicated by a small ground sign on left of the screen when the oscilloscope is on.

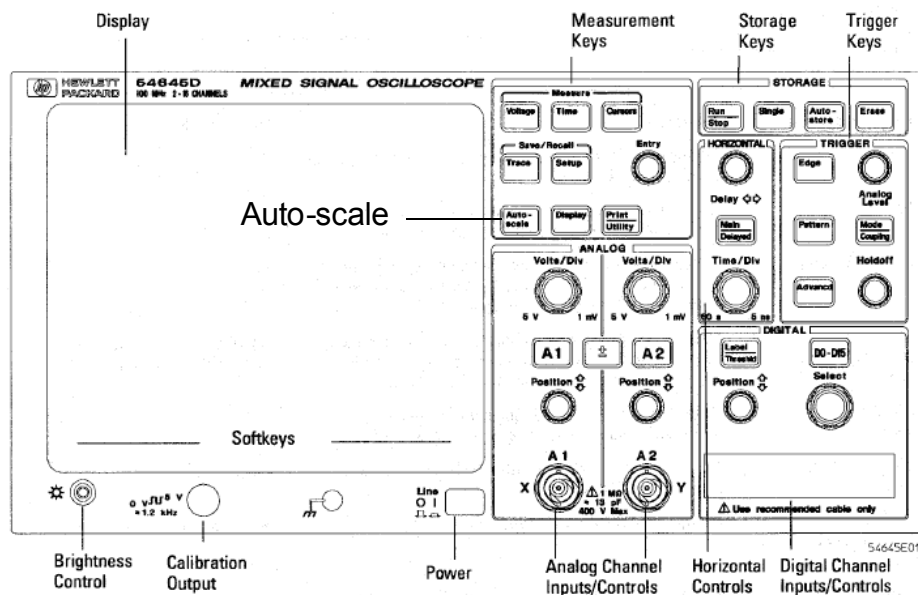

HP 54645D Mixed-Signal Oscilloscope Front Panel

Figure 16

4. Hands-on experiment guide

Part I: Instrument practice

- Set up a DC voltage of 2.5 V with current limit of 0.5 A using the HP E3631A power supply and then measure this DC voltage output using the digital multimeter HP 34401A. Use the oscilloscope HP 54645D to measure the same voltage (don't forget to setup the probe menu to **Auto 1** first). Use V_{avg} in the voltage measurement function to get the DC voltage value. Make sure the DC power supply OUTPUT OFF whenever you change the connection.
- Use the HP 33120A function generator to generate a sinusoidal wave with frequency of 1 kHz, output peak-to-peak amplitude of 2 V and the average value centered at 1 V. Display this wave form on the oscilloscope. In order to get a signal with amplitude of 2 V displayed on the oscilloscope, what amplitude should be set on the function generator? In order to have the average

value centered at 1 V (signal amplitude minimum is 0 V), what offset value should be set on the function generator? (Hint: If you have no clue how to get this signal, start with amp V_{pp} of 2 V and offset 1 V and see what you observe on the scope. Then you can adjust the function generator according to what you see on the scope to get the desired signal waveform.)

- c. Use the cursors to measure peak-to-peak voltage and the period of the waveform. Calculate the frequency. Now take the same measurements using the oscilloscope's built-in peak-to-peak voltage, period and frequency measurement functions. Record the results.
- d. Read the color code to get the resistance values of all the resistors that are provided. Measure the resistance using the digital multimeter Ohmmeter function to verify your reading. Are they within the tolerance?

Part II Circuit design and measurement

- a. Connect a 1 k Ω resistor with the power supply. Try to apply 1 V, 2 V, 3 V and 4 V to the resistor and use the multimeter to measure the current going through the resistor in each case. Graph current vs. voltage. What does the slope represent? Does it obey Ohm's law?
- b. Now connect the power supply with an LED (pick a color you like). Apply DC voltage from 0 V to 3 V, with 0.1 V step size, and monitor the current going through the LED. Do you see a threshold behavior? What is the threshold voltage of the LED? Try to look at the LED from the top while you are changing the voltage from 0 V to 3 V, how does the brightness change? Can you tell the threshold from watching the light? (Hint: use your hand as a shield to cover the LED so that you can see better with the room lights on.) Now reverse the polarity of the power supply by switching the wires. What happens now when you vary the voltage from 0V to 3 V?

Note: The current limit on the DC power supply should be set to 20 mA to avoid damaging of the LED.

Optional: try different color LEDs and see if there is any difference on the threshold voltage.

- c. Apply 5 V ideal voltage source to a 1-k Ω resistor and an LED in series and see if the LED lights up. Then put in one more 1-k Ω resistor in series with the other two components and see if the LED is brighter or darker? And why? Now connect the other two 1-k Ω resistors in parallel and then in series with another LED, is the LED brighter or darker in this case compare to the previous two cases? Why?
- d. Keep one resistor in series with an LED from the previous step (step c) and switch the power supply to the function generator to build a blinking LED. Set a sinusoidal signal with 0 V offset, 5 V V_{pp} and 5 Hz frequency on the function generator. Human eye can detect signal rate < 40 Hz. Try to change the frequency of the signal on the function generator to measure the upper limit of the frequency that your eyes can detect.
- e. Set the function generator to give 1-Hz sinusoidal signal output (the rest of the setup is the same as previous step). Modify the circuit in the previous step (d) by

adding in one more LED (same color) so that two LEDs blinking in phase (on/off at the same time). Can you make two LEDs blinking out of phase (on/off alternatively)?

- f. Set up the function generator with 5 V V_{pp} and 500 Hz sinusoidal signal, and then hook it up to the speaker/buzzer. Change the signal frequency and listen to the sound the speaker generated. Give a frequency range that your ears feel comfortable with the sound. Keep the frequency at which the sound is loud and enjoyable, and then change the signal pattern from **Sin** to **Square**, to **Triangle** to **Sawtooth** and finally **Noise**. How are they different from each other?

Note: Don't try to find the upper limit of your ears. Stop if you don't feel the sound is pleasant. Sound with too high frequency may damage your hearing.

- g. Now hook up the speaker/buzzer directly to the oscilloscope and use it as a microphone. Try to speak, sing, whistle or breathe to the buzzer and look at the signal pattern you generated on the oscilloscope. You may need to press the **Auto-scale** button while you are performing to get a proper signal displayed on the screen.

Appendix I Component and equipment list

Component		
Resistor	1 k Ω	4
Resistor	2.2 k Ω	1
Resistor	4.7 k Ω	1
LED	red/yellow/green	2
Speaker/Buzzer		1

Equipment
Power Supply HP E3631A
Digital Multimeter HP 34401A
Function Generator HP 33120A
Oscilloscope HP 54645D
Breadboard