

EECS 16A Designing Information Devices and Systems I Discussion 10A
 Fall 2022

1. Capacitive Touchscreen

Consider the 2-dimensional capacitive touchscreen in Figure 1. Node F (green) represents the contact area of the finger with the top insulator. The finger contact area has horizontal width w_2 and depth (into the page) d_1 . The ‘top’ metal at node E_1 (red) has width w_1 and depth d_1 . The ‘bottom’ metal at node E_2 (grey) has width w and depth d_2 , where w is much larger than w_1 and w_2 . The vertical distance between the top metal (red) and bottom plate (grey) is t_1 , and the vertical distance between the finger (green) and the bottom plate (grey) is t_2 .

Table 1: Touchscreen Dimension Values

d_1	d_2	w_1	w_2	t_1	t_2
10mm	1mm	1mm	2mm	2mm	4mm

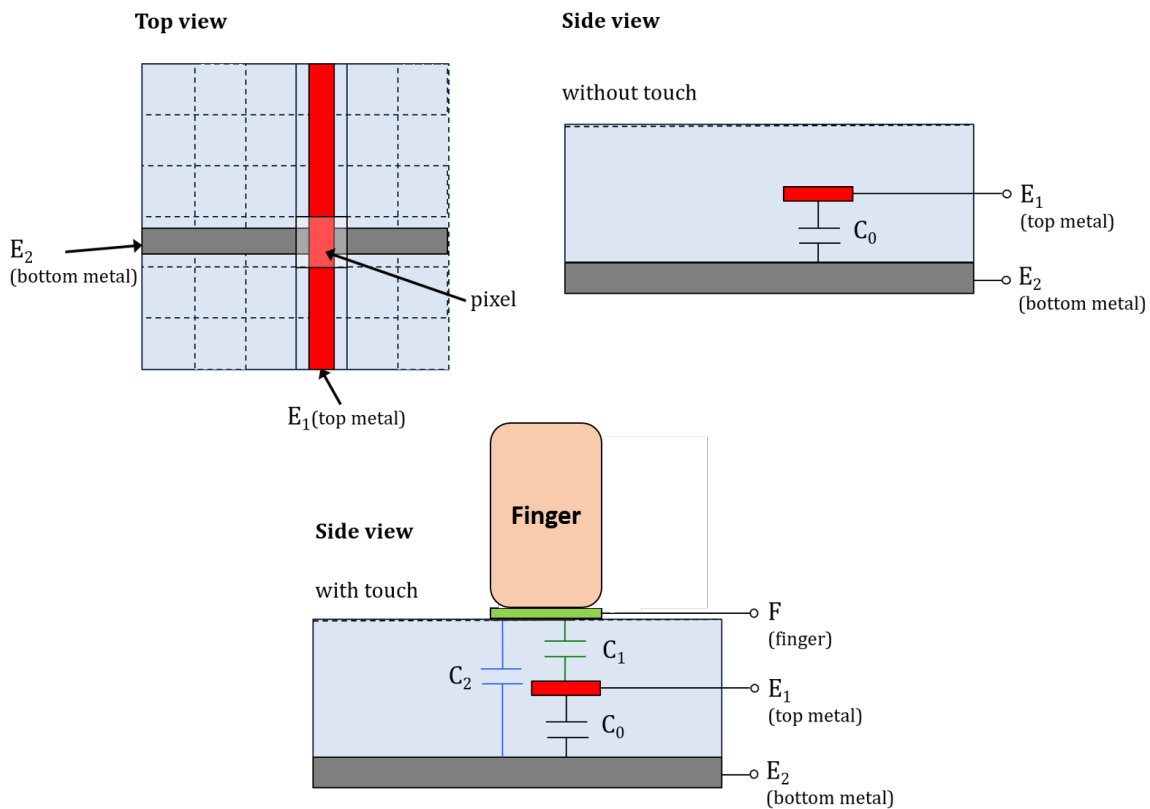

Figure 1: Model of capacitive touchscreen.

- (a) Draw the equivalent circuit of the touchscreen that contains the nodes F , E_1 , and E_2 when: (i) there is no finger present; and (ii) when there is a finger present. Express the capacitance values in terms of C_0 , C_1 , and C_2 .

Hint: Note that node F represents the finger. When there is no touch node, F would be non-existent.

- (b) What are the values of C_0 , C_1 , and C_2 ? Assume the insulating material has a permittivity of $\epsilon = 4.43 \cdot 10^{-11}$ F/m and the thickness of the metal layers is small compared to t_1 (so you can ignore the thickness of the metal layers). Also assume that the right edge of the top metal (red area) in the diagram is aligned with the right edge of the finger (green area) in the diagram.

(c) What is the effective capacitance between the two metal plates (nodes E_1 and E_2) when a finger is present?

(d) What are the advantages of a capacitive touchscreen over a resistive touchscreen?

Hint: Can we do multi-finger detections using a capacitive touchscreen? What about resistive touchscreens?

2. Comparators

For each of the circuits shown below, plot V_{out} for V_{in} ranging from -10 V to 10 V for part (a) and from 0 V to 5 V for part (b).

(a)

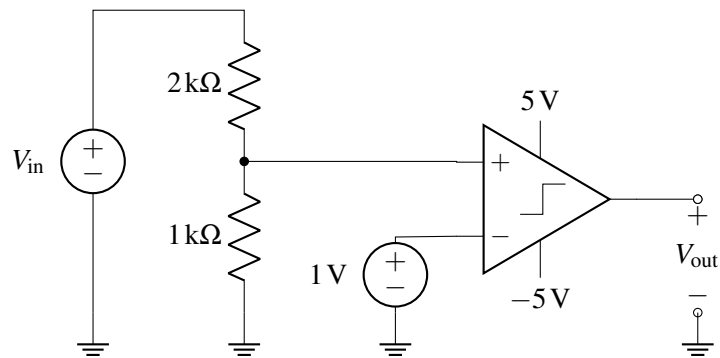

(b) **Practice**

