EECS 16A Designing Information Devices and Systems I

Fall 2022 Homework 8

This homework is due Friday, October 28, 2022 at 23:59. Self-grades are due Monday, October 31, 2022, at 23:59.

Submission Format

Your homework submission should consist of **one** file.

- `hw8.pdf`: A single PDF file that contains all of your answers (any handwritten answers should be scanned).

Submit the file to the appropriate assignment on Gradescope.

1. Reading Assignment

For this homework, please read Notes 15 and 16. Note 15 covers superposition and equivalence, two very helpful techniques to help simplify circuit analysis. Note 16 will provide an introduction to capacitors (a circuit element which stores charge), capacitive equivalence, and the underlying physics behind them.

- (a) Describe the key ideas behind how a capacitor works. How are capacitor equivalences calculated? Compare this with how we calculate resistor equivalences.

2. Equivalent Resistance

Learning Goal: *The objective of this problem is to practice finding the equivalent to a series/parallel combination of resistors.*

- (a) Find the equivalent resistance looking in from points a and b . In other words, express the resistive network in the dashed box as one resistor.

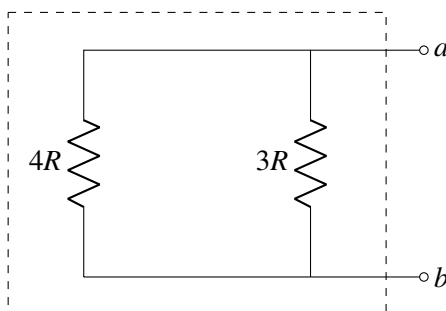

- (b) Find the equivalent resistance looking in from points a and b . In other words, express the resistive network in the dashed box as one resistor.

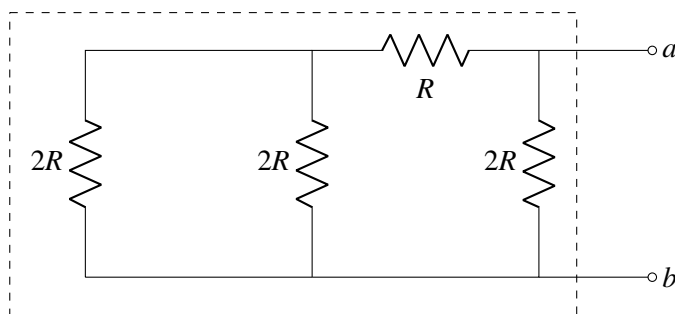

(c) Find the equivalent resistance looking in from points a and b . In other words, express the resistive network in the dashed box as one resistor.

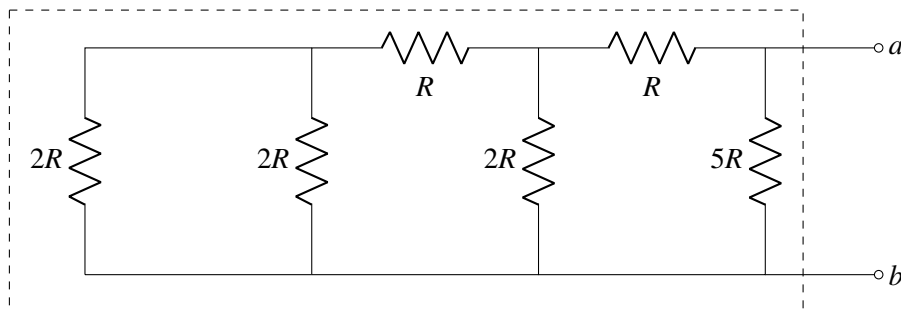

(d) **(OPTIONAL, CHALLENGE)** Find the equivalent resistance for the infinite ladder looking in from points a and b . In other words, express the resistive network in the dashed region as one resistor. (Hint: Let's call the resistance looking in from a and b as R_{in} , and the resistance looking to the left from points c and d as R_{in1} . Replace the entire circuit to the left of points c and d with a resistor whose value is given by R_{in1} . Find the relationship between R_{in} and R_{in1} using this circuit. Find another relationship between R_{in} and R_{in1} using the fact that the ladder is infinite. For an infinite ladder, adding another branch does not change the equivalent resistance. Think of this as a convergent infinite series.)

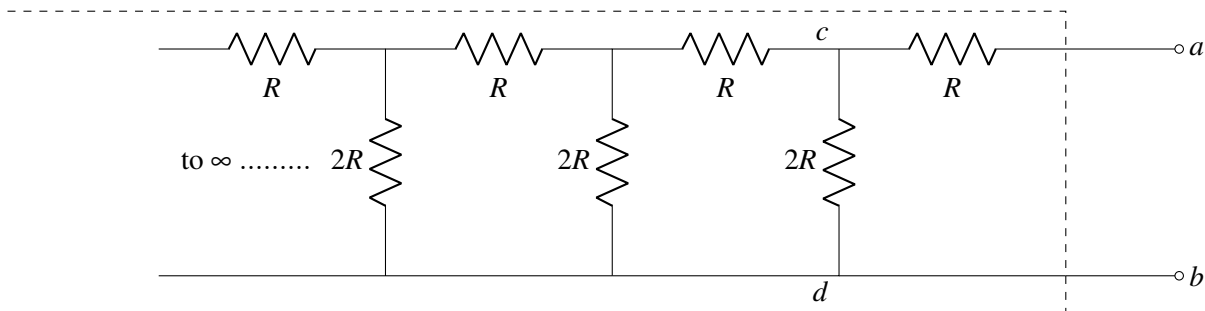

As a first step you can replace the circuit looking to the left from c and d by R_{in1} .

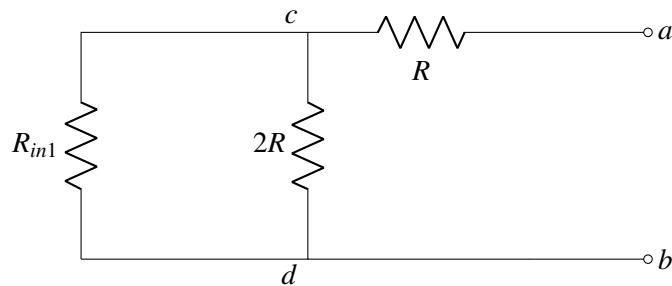

3. Why Bother With Thévenin Anyway?

- (a) Find a Thévenin equivalent for the circuit shown below looking from the terminals a and b . (Hint: That is, find the open circuit voltage V_R across the terminals a and b . Also, find the equivalent resistance looking from the terminals a and b when the input voltage source is zeroed.)

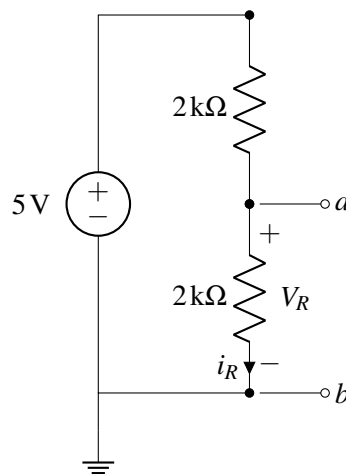

- (b) Now consider the circuit shown below where a load resistor of resistance R_L is attached across the terminals a and b . Compute the voltage drop V_R across the terminals a and b in this new circuit with the attached load. Express your answer in terms of R_L . (Hint: We have already computed the Thévenin equivalent of the unloaded circuit in part (a). To analyze the new circuit, attach R_L as the load resistance across the Thévenin equivalent computed in part (a), as shown in the figure below. One of the main advantages of using Thévenin (and Norton) equivalents is to avoid re-analyzing different circuits which differ only by the amount of loading.)

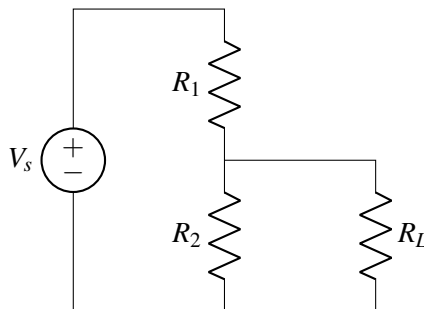

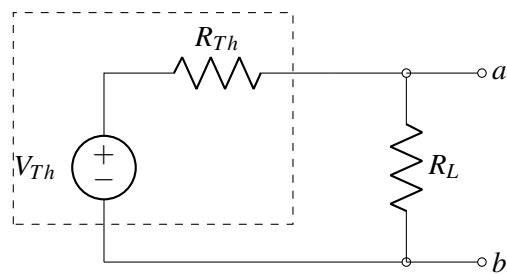

- (c) Now compute the voltage drop V_R for three different values of R_L equal to $5/3 \text{ k}\Omega$, $5 \text{ k}\Omega$, and $50 \text{ k}\Omega$? What can you comment on the value of R_L needed to ensure that the loading does not reduce the voltage drop V_R compared to the unloaded voltage V_R computed in part (a)?
- (d) Say that we want to support loads in the range of $8 \text{ k}\Omega$ to $10 \text{ k}\Omega$. We would like to maintain 3 V across these loads. How can we approximately achieve this by setting R_1 and R_2 in the following circuit?

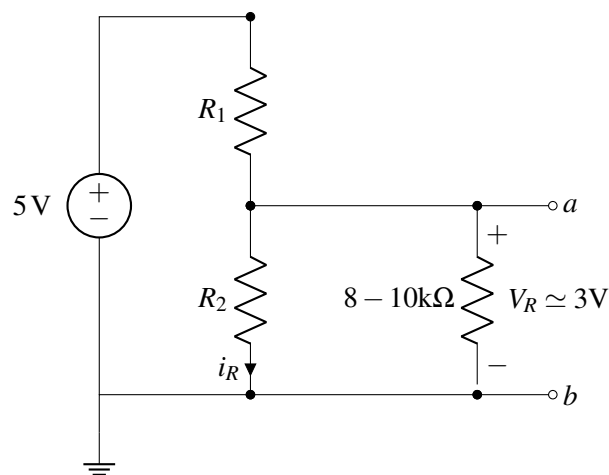

- (e) Thus far, we have seen how to use Thévenin equivalents to compute the voltage drop across a load without re-analyzing the entire circuit. We would like to see if we can use the Thévenin equivalent for power computations. Consider the case where the load resistance $R_L = 8 \text{ k}\Omega$, $V_S = 5 \text{ V}$, $R_1 = R_2 = 2 \text{ k}\Omega$. Compute the power dissipated across the load resistor R_L both using the original circuit and the Thévenin equivalent. Are they equal? Now, compute the power dissipated by the voltage source V_S in the original circuit. Also, compute the power dissipated by the Thévenin voltage source V_{Th} in the Thévenin equivalent circuit. Is the power dissipated by the two sources equal?

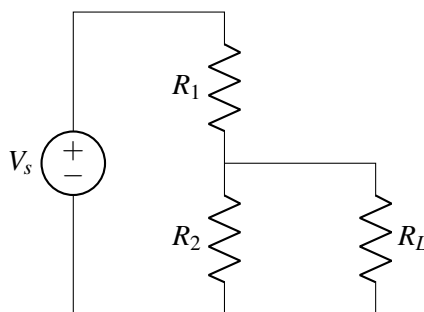

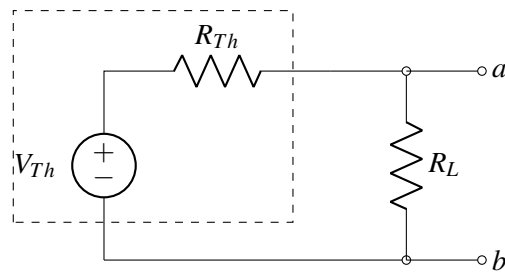

4. Thévenin and Norton Equivalent Circuits

Find the Thévenin and Norton equivalent circuits seen from terminals A and B.

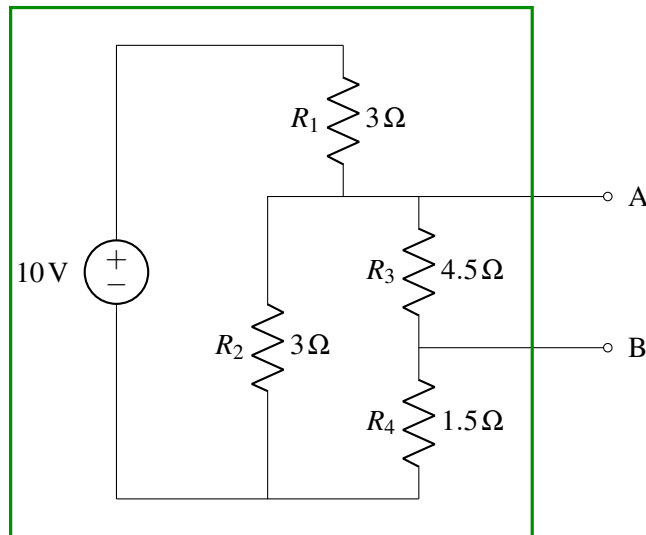

5. Superposition

Learning Goal: The objective of this problem is to help you practice solving circuits using the principles of superposition.

Find the node potential V_a indicated in the diagram using superposition. Be careful when solving to take into account where the reference potential is.

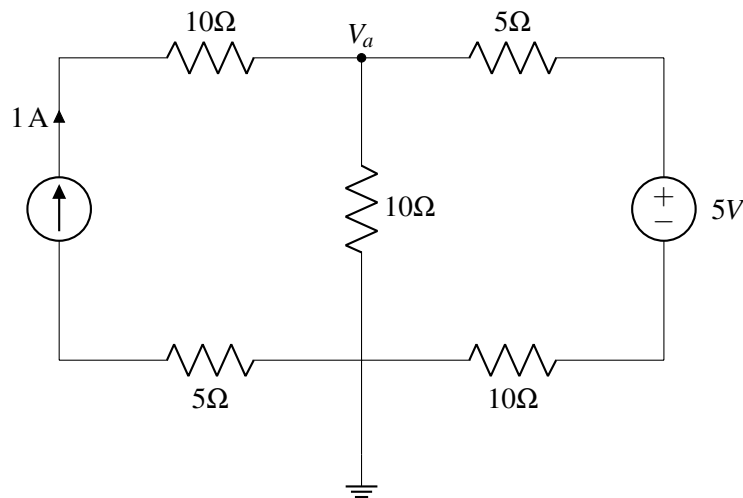

6. It's finally raining!

A lettuce farmer in Salinas Valley has grown tired of weather.com's imprecise rain measurements. Therefore, they decided to take matters into their own hands by building a rain sensor. They placed a square tank outside and attached two metal plates to two opposite sides in an effort to make a capacitor whose capacitance varies with the amount of water inside.

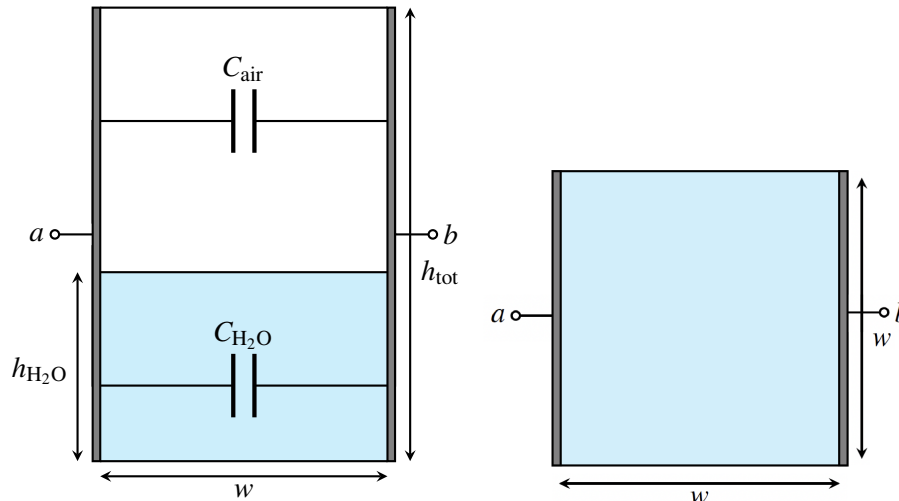

Tank side view (left) and top view (right).

The width and length of the tank are both w (i.e., the base is square) and the height of the tank is h_{tot} .

- What is the capacitance between terminals a and b when the tank is full? What about when it is empty?
Note: the permittivity of air is ϵ , and the permittivity of rainwater is 71ϵ .
- Suppose the height of the water in the tank is $h_{\text{H}_2\text{O}}$. Model the tank as a pair of capacitors in parallel, where one capacitor has a dielectric of air, and one capacitor has a dielectric of water. Find the total capacitance between the two plates using equivalence. Call this capacitance C_{tank} .
- After building this capacitor, the farmer consults the internet to assist them with a capacitance-measuring circuit. A fellow internet user recommends the following:

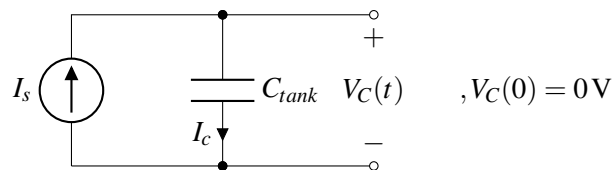

In this circuit, C_{tank} is the total tank capacitance that you calculated earlier. I_s is a known current supplied by a current source.

The suggestion is to measure V_C for a brief interval of time, and then use the difference to determine C_{tank} .

Determine $V_C(t)$, where t is the number of seconds elapsed since the start of the measurement. You should assume that before any measurements are taken, the voltage across C_{tank} , i.e. V_C , is initialized to 0 V, i.e. $V_C(0) = 0$.

- Using the equation you derived for $V_C(t)$, describe how you can use this circuit to determine C_{tank} and $h_{\text{H}_2\text{O}}$.

7. Prelab Questions

These questions pertain to the Pre-Lab reading for the Touch 3A lab. You can find the reading under the Touch 3A Lab section on the 'Schedule' page of the website.

- (a) What basic principle governs the working of the capacitive touchscreen?
- (b) What is the equation that relates the Current (I), Voltage (V) and Capacitance (C) of a capacitor?

8. Homework Process and Study Group

Who did you work with on this homework? List names and student ID's. (In case you met people at homework party or in office hours, you can also just describe the group.) How did you work on this homework? If you worked in your study group, explain what role each student played for the meetings this week.