EECS 16A Designing Information Devices and Systems I
Fall 2018

Midterm 2

Midterm 2 Solution

PRINT your student ID: _____

PRINT AND SIGN your name: _____, _____ _____
(last name) (first name) (signature)

PRINT your discussion section and GSI(s) (the one you attend): _____

Name and SID of the person to your left: _____

Name and SID of the person to your right: _____

Name and SID of the person in front of you: _____

Name and SID of the person behind you: _____

1. What is one of your hobbies? (2 Points)

2. Tell us about something that makes you happy. (2 Points)

Do not turn this page until the proctor tells you to do so. You may work on the questions above.

PRINT your name and student ID: _____

3. Know Thy Nodes (10 points)

Refer to the circuit below for the entirety of this question.

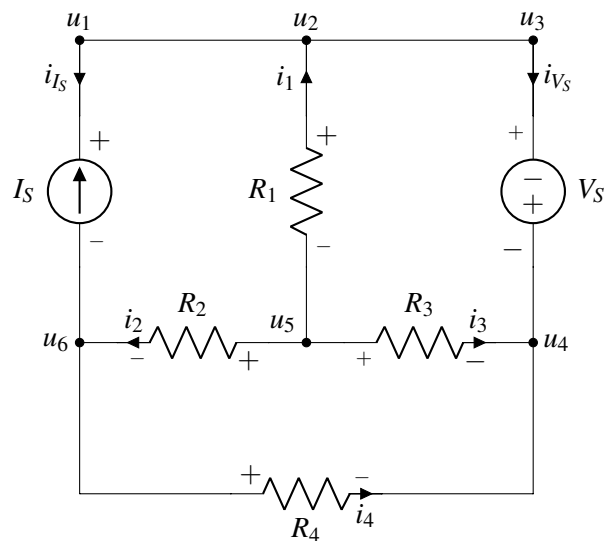

- (a) (2 points) Which element(s) of the circuit have current-voltage labeling that violates Passive Sign Convention? Fill in the circle on the left of all the right answer(s).

I_s V_s R_1 R_2 R_3 R_4

Solution: The correct answer is R_1 . Element voltage $+/-$ should be labeled so that i_1 enters the $+$ sign or exits from the $-$ sign, according to the passive sign convention.

- (b) (2 points) There are more node labelings (u_1, \dots, u_6) than necessary. There is one subset of node labelings that are all for the same node. Fill in the circles on the left of all nodes that can be merged into a single node.

u_1 u_2 u_3 u_4 u_5 u_6

Solution: Nodes $u_1, u_2,$ and u_3 are all connected by an ideal wire, so they are all at the same potential and are all thus the same node. We can merge these into a single node.

- (c) (3 points) Write the equation for current-voltage relationship of R_3 in terms of resistance, current and node potentials.

Solution:

$$R_3 = \frac{u_5 - u_4}{i_3}$$

Any equation that can be rearranged to become this is fine.

- (d) (3 points) Write the KCL equation for the currents associated with node u_6 in terms of i_1, \dots, i_4, i_{I_s} and i_{V_s} .

Solution: At node u_6 :

$$\sigma \text{currents in} = \sigma \text{currents out} \rightarrow i_{I_s} + i_2 = i_4$$

Any equation that can be rearranged to become this is fine.

PRINT your name and student ID: _____

4. A Tale of Two (Independent) Sources (12 points)

You are given the following circuit and asked what function it serves. We will use superposition to discover how the circuit can be used. g is a constant value with units $[\frac{A}{V}]$.

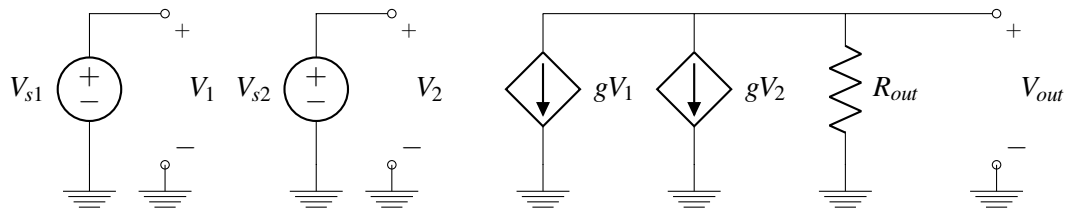

- (a) (3 points) First turn off V_{s2} . When only V_{s1} is active, let the output voltage $= V_{out}$ be $V_{out,1}$. What is $V_{out,1}$?

Solution: In that case, $V_1 = V_{s1}$ and $V_2 = 0V$. As a result, the controlled source gV_2 acts like an open-circuit. The circuit reduces to the following:

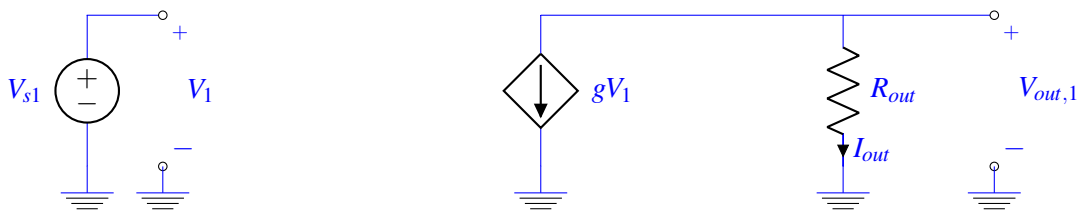

Applying KCL, we see that $I_{out} = -gV_1$. So

$$V_{out,1} = I_{out}R_{out} = -gR_{out}V_{s1}$$

- (b) (3 points) Now turn off V_{s1} . When only V_{s2} is active, let the output voltage $= V_{out}$ be $V_{out,2}$. What is $V_{out,2}$?

Solution: This analysis is just like the previous step. $V_1 = 0V$ and $V_2 = V_{s2}$. As a result, the controlled source gV_1 acts like an open-circuit. The circuit reduces to the following:

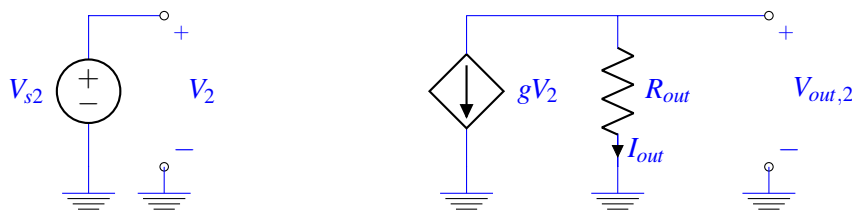

Applying KCL, we see that $I_{out} = -gV_2$. So

$$V_{out,2} = I_{out}R_{out} = -gR_{out}V_{s2}$$

- (c) (3 points) What is V_{out} , the output voltage, when both V_{s1} and V_{s2} are active? If $g = \frac{1}{R_{out}}$, then what is the function of the circuit in terms of V_{s1} and V_{s2} ?

Solution: By superposition, $V_{out} = V_{out,1} + V_{out,2}$. Therefore,

$$V_{out} = -gR_{out}(V_{s1} + V_{s2})$$

If $g = \frac{1}{R_{out}}$, then $V_{out} = -(V_{s1} + V_{s2})$. That means this circuit acts as an inverting summer: it adds the inputs V_{s1} and V_{s2} and then flips the sign of the sum.

- (d) (3 points) Find the Thevenin equivalent of this circuit with respect to the output terminal, i.e. find the Thevenin equivalent of the boxed circuit with respect to terminals a and b , where $g = \frac{1}{R_{out}}$.

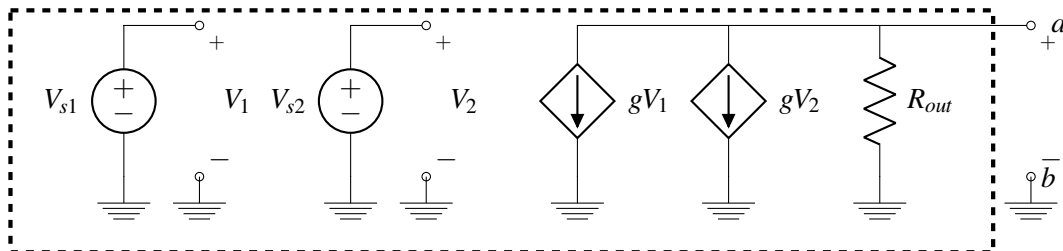

Solution: First, we must find $V_{th} = V_{oc}$. This is just V_{out} measured without a load connected: we got this value in part (c) using superposition.

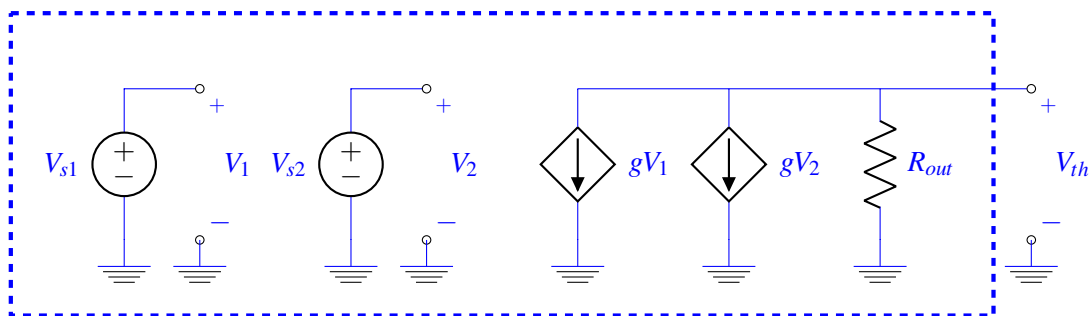

$$V_{th} = -gR_{out}(V_{s1} + V_{s2}) = -(V_{s1} + V_{s2})$$

Next, we must find R_{th} . We turn off all independent voltage sources (i.e. $V_{s1} = 0$ and $V_{s2} = 0$ are replaced by a wire). This means that the dependent current sources output $g \cdot 0 = 0A$. Consequently, we can replace the dependent current sources with open circuits. Applying these simplifications, we end up with the following circuit to find R_{th} :

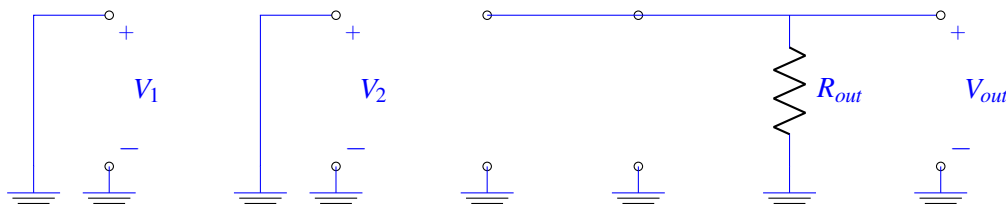

By inspection (or by applying the V_{test}, I_{test} method), we observe that $R_{th} = R_{out}$. So our equivalent Thevenin circuit will look like the following:

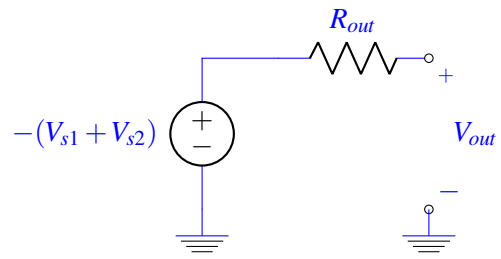

PRINT your name and student ID: _____

5. Hot Dogs (14 points)

Michael and Alice are going on a picnic with Daisy the robot dog! But when they arrive at the park, a thunderstorm starts with lots of lightning... However, Daisy still wants to play in the park!

- (a) (6 points) We want to understand what will happen *if* Daisy is struck by lightning. A lightning bolt is represented with a voltage source of 1000 Volts (1kV) with reference to the Earth. The lightning travels through the ionized air ($R_{Air} = 4$ kilo-Ohms ($4k\Omega$)), and through Daisy $R_{Daisy} = 4k\Omega$ before reaching the ground. Daisy can withstand up to 10 Watts (W) of power before breakdown.

Using the circuit diagram in Figure 5.1, find if it is safe for Daisy to be struck by a lightning bolt. Justify your answer by showing your work!

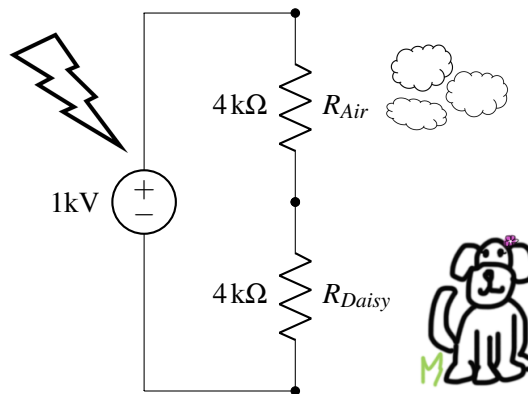

Figure 5.1: Circuit for Part (a)

Solution: No, this is way too much power for Daisy! Below we compute that $62.5kW$ of power is dissipated across Daisy.

$$V_D = \frac{4k\Omega}{4k\Omega + 4k\Omega} 1kV = 0.5kV$$

$$I_D = \frac{V_D}{R_D} = \frac{0.5kV}{4k\Omega} = \frac{1}{8}A$$

$$P_D = V_D I_D = \left(\frac{1}{8}A\right)\left(\frac{1}{2}kV\right) = 62.5W$$

- (b) (8 points) Laura also brings along her dog, Elton, for the picnic. Elton has a resistance of $R_{Elton} = 2k\Omega$ and can withstand up to 25W of power. If Daisy and Elton hide together next to a tree of resistance $R_{Tree} = 4k\Omega$ as shown in the Figure 5.2, would either of the dogs withstand being struck by lightning? Show your work.

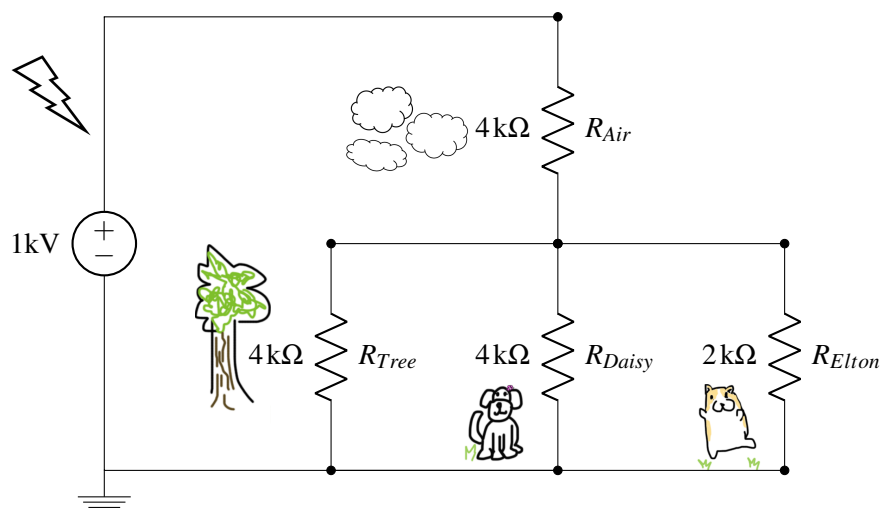

Figure 5.2: Circuit for Part (b)

Solution: The equivalent resistance of the three resistors in parallel is:

$$R_{eq} = R_T \parallel R_D \parallel R_E = 4\text{k}\Omega \parallel 4\text{k}\Omega \parallel 2\text{k}\Omega = 1\text{k}\Omega$$

The voltage across the dogs can be computed using the voltage divider equation:

$$V_D = V_T = V_E = \frac{1}{1+4} 1\text{kV} = 0.2\text{kV}$$

The power dissipated on each dog can be computed using the V and R .

$$P_D = \frac{V_D^2}{R_D} = \frac{0.2\text{kV}^2}{4\text{k}\Omega} = 10\text{W}$$

$$P_E = \frac{V_E^2}{R_E} = \frac{0.2\text{kV}^2}{2\text{k}\Omega} = 20\text{W} < 25\text{W}$$

If struck by lightning, Daisy would be fine (barely) and Elton should survive as well!

PRINT your name and student ID: _____

6. Fire Away! (18 points)

You have graduated from UC Berkeley to become an engineer for the International Fleet, and are tasked with improving the firing system of their spaceships for the battle against Formics.

These ships, which will be commanded by Ender, were built with the ability to fire a special attack known as the Molecular Disruption Device (MDD). However, there is a problem: the capacitive touchscreens on the ships heat up with every use of the MDD, and as the touchscreen heats up, the properties of the faulty dielectric material change. Without the touchscreen, the pilots of Ender’s fleet won’t be able to fire at enemy ships!

The touchscreen configuration is shown below, where Bar1 and Bar2 are two conductors with terminals E_1 and E_2 respectively. **The faulty dielectric material, between Bar1 and Bar2, is represented by the darkly shaded rectangle in the Figures 6.3 and 6.4.**

0.5

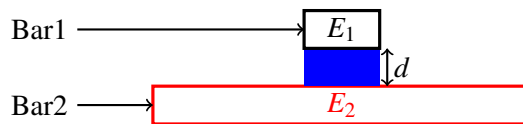

Figure 6.1: : No touch

0.5

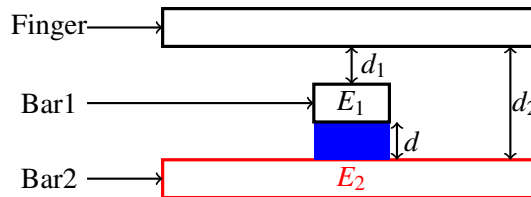

Figure 6.2: : With touch

Figure 6.3: Side View

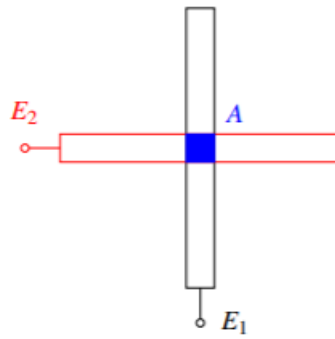

Figure 6.4: Top View

Your job is to model this problem as a circuit configuration, where you're measuring the voltage across points E_1 and E_2 . Then you can figure out what the limiting factors are and try to improve the ships of Ender's fleet.

PRINT your name and student ID: _____

- (a) (2 points) Model the above configuration as a system of capacitors, **for when there is no touch** as shown in Figure 6.1. Draw your circuit between the terminals E_1 and E_2 below.

You can draw a maximum of 3 capacitors to model this system. You **do not** have to label any properties of the capacitors yet.

Solution:

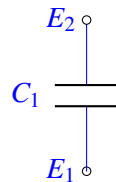

- (b) (4 points) Model the configuration shown in Figure 6.2, with the gap between the bars, as a system of capacitors, **for when there is a touch**. Draw your circuit between the terminals E_1 and E_2 below.

You can draw a maximum of 3 capacitors to model this system. You **do not** have to label any properties of the capacitors yet. **Hint:** *The finger is conductive. Consider it to be a node in your circuit diagram.*

Solution:

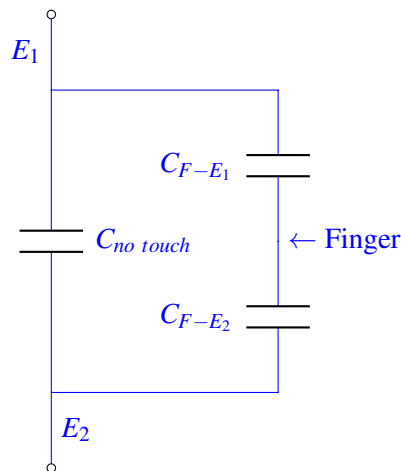

- (c) (5 points) You ask the pilots to run some experiments, and find out that the dielectric material between Bar1 and Bar2 has a permittivity ϵ that starts at 12 F/mm and increases by 1 F/mm instantly every time the screen is touched. Using the variables d , d_1 , d_2 , and A , write the capacitance of the capacitor between Bar1 and Bar2 as a function of n , where n is the number of touches that have already happened (**there is no touch now**).

(Note: 12 Farads/mm is a very large permittivity. Normal permittivity values would be on the order of 10^{-12} F/m.)

Solution:

The formula for capacitance is $\epsilon * A/d$

$$\epsilon(n) = 12 + n$$

$$C_{notouch}(n) = (12 + n) \frac{A}{d}$$

(d) (7 points) **For the rest of this problem, use the circuit below to model the capacitive touchscreen.**

You are now given that $C_{F-E_1} = 8F$, $C_{F-E_{2L}} = 4F$, and $C_{F-E_{2R}} = 4F$. Also, $d = 2mm$, $d_1 = 3mm$, $d_2 = 7mm$, and $A = 4mm^2$.

(Note: $8F$ is a very large capacitance. Normal capacitance values would be on the order of nano-Farads, which are 10^{-9} of a Farad.)

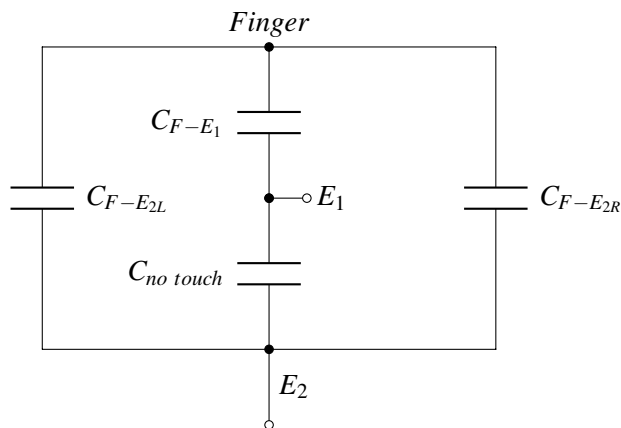

- Calculate the equivalent capacitance of the circuit between terminals E_1 and E_2 at the following times: (1) **during the n^{th} touch** (assume that the permittivity of faulty dielectric changes **instantly as the finger touches the screen.**) and (2) **after the n^{th} touch** (when the finger is not touching anymore.)
- The display cannot detect the touch if the difference between the touch and no-touch capacitances is smaller than 10% of the no-touch capacitance. Determine the **number of times the pilot can fire** before the display cannot detect the touch anymore. Show all your work.

Solution: $C_{notouch} = (12 + n) * A/d = 24 + 2n$

$$C_{touch} = (C_{F-E_1} || C_{F-E_2}) + C_{notouch} = (8 || 8) + 24 + 2n = 28 + 2n$$

The display will not be able to detect a touch if:

$$\begin{aligned} C_{touch} - C_{notouch} &< 0.1C_{notouch} \\ 28 + 2n - 24 - 2n &< 0.1(24 + 2n) \\ 4 &< 0.1(24 + 2n) \\ 40 &< 24 + 2n \\ 16 &< 2n \\ n &> 8 \end{aligned}$$

PRINT your name and student ID: _____

7. Noisy Parties (20 points)

To celebrate the (peaceful and very reasonable) end of the pizza-on-pineapple war, course staff decided to throw a party for the entire class! (Disclaimer: Not really) You and your friends want to take a picture to commemorate the night. In the imaging lab, you learned about how to make a camera with a single photodiode and a projector. Most modern cameras, however, have many photodiodes and do not need a sweeping light source like what you used in lab and need to work in non-ideal, non-laboratory conditions.

- (a) (4 points) We can model a photodiode as a capacitor in parallel with a current source:

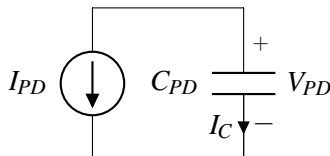

Figure 7.1: Photodiode circuit model

The current I_{PD} is related to the intensity of the light shining on the photodiode. Start with the following equations:

- $V_{PD}(t = 0) = V_{DD}$
- $I_C = C_{PD} \frac{dV_{PD}}{dt}$

Begin with the above equations and show that $V_{PD}(t) = V_{DD} - \frac{I_{PD}}{C_{PD}}t$.

Hint: Follow passive sign convention.

Solution: In the diagram, I_{PD} goes in the opposite direction of the passive sign convention with V_{PD} ! That said,

$$\begin{aligned} I_{PD} &= -I_C \\ &= -C_{PD} \frac{dV_{PD}}{dt} \\ \frac{dV_{PD}}{dt} &= -\frac{I_{PD}}{C_{PD}} \\ V_{PD}(t) - V_{PD}(0) &= -\frac{I_{PD}}{C_{PD}}(t - 0) \\ V_{PD}(t) &= V_{DD} - \frac{I_{PD}}{C_{PD}}t \end{aligned}$$

Taking the integral or using $\frac{\Delta V_{PD}}{\Delta t}$ both warrant full credit.

- (b) (6 points) When feeding information from circuits into computers, we need to convert from our continuous-valued analog signals into discrete-valued digital signals the computer can understand using an analog-to-digital converter (ADC).

One type of ADC uses the time it takes for an event to occur in its conversion (converting time to the digital domain involves counting at a steady rate until the event occurs). We care about the time it takes for the comparator output to change.

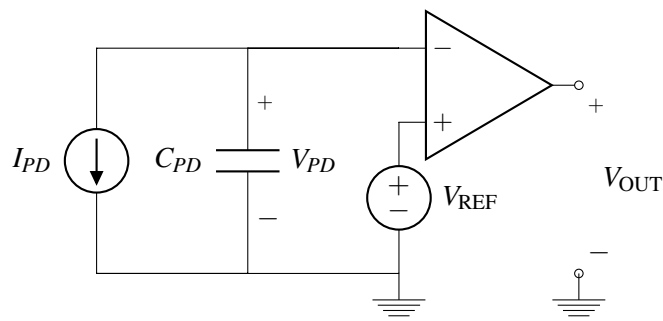

Parameter	Unit	Value
I_{PD}	A	$1 \cdot 10^{-3}$
C_{PD}	F	$1 \cdot 10^{-9}$
V_{REF}	V	0.5
V_{DD}	V	1.0

Figure 7.2: Integrating ADC

Table 7.1: Numerical values for parts (b) and (c)

Draw $V_{PD}(t)$ in the graph below, where $V_{PD}(t=0) = V_{DD}$. Clearly label the following with numerical values:

- Slope of the $V_{PD}(t)$ vs. t curve, i.e. $\frac{dV_{PD}}{dt}$.
- t_{flip} where $V_{PD}(t_{\text{flip}}) = V_{REF}$ and the comparator output goes high for the first time
- t_{zero} where $V_{PD}(t_{\text{zero}}) = 0V$

Hint: $1\mu\text{s} = 1 \cdot 10^{-6}\text{s}$.

Solution: We know that V_{PD} will begin high and decrease linearly, so V_{OUT} will start low and go high when $V_{PD} = V_{REF}$. Using the expression from (a):

$$\begin{aligned}
 V_{PD}(t_{\text{flip}}) &= V_{REF} \\
 V_{DD} - \frac{I_{PD}}{C_{PD}} t_{\text{flip}} &= V_{REF} \\
 t_{\text{flip}} &= \frac{C_{PD}}{I_{PD}} (V_{DD} - V_{REF}) \\
 &= 0.5 \cdot 10^{-6}\text{s}
 \end{aligned}$$

$$\begin{aligned}
 V_{PD}(t_{\text{zero}}) &= 0 \\
 V_{DD} - \frac{I_{PD}}{C_{PD}} t_{\text{zero}} &= 0 \\
 t_{\text{zero}} &= \frac{C_{PD}}{I_{PD}} \cdot V_{DD} \\
 &= 1 \cdot 10^{-6}\text{s}
 \end{aligned}$$

Plotting the result:

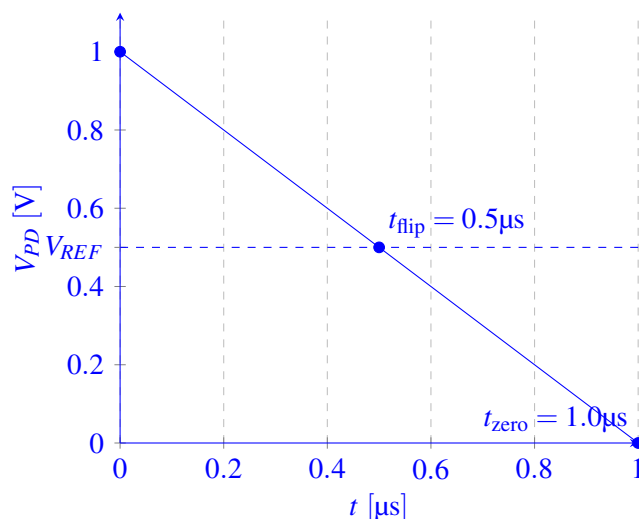

(c) (10 points) Everyone in your picture is holding still, and in previous parts we assumed a constant current across the capacitor. However, someone just turned on strobe lights! You only want a picture of people, so we can treat the flashing lights as interference. Now our full circuit looks like Figure 7.3

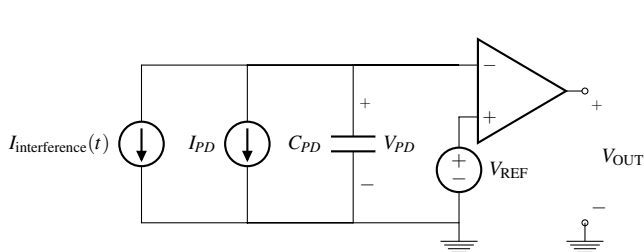

Figure 7.3: Model with interference

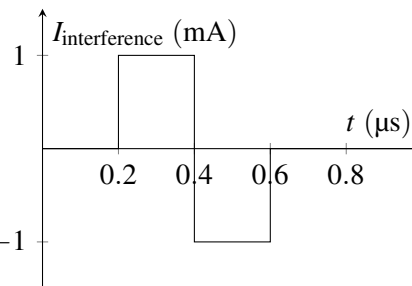

Figure 7.4: Interference current for part (c)

For this subpart, use the interference current defined in Figure 7.4 and the values in Table 7.1 (repeated for convenience).

Parameter	Unit	Value
I_{PD}	A	$1 \cdot 10^{-3}$
C_{PD}	F	$1 \cdot 10^{-9}$
V_{REF}	V	0.5
V_{DD}	V	1.0

Table 7.1 repeated for convenience

Draw $V_{PD}(t)$ in the graph below given $V_{PD}(0) = V_{DD}$. Clearly label $\frac{dV_{PD}}{dt}$ for every line segment in your graph with numerical values. Also find t_{flip} where $V_{PD}(t_{flip}) = V_{REF}$.

Hint: $V_{PD}(t)$ is continuous.

Solution: Now we have two current sources in parallel, one of which is constant and one of which varies with time. Because they're in parallel, we can combine them into a single current source $I_{total}(t) = I_{interference}(t) + I_{PD}$.

Plotting the total current:

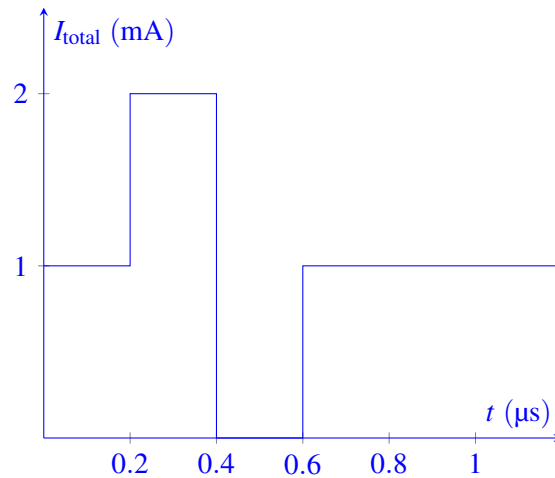

With this and $\frac{dV_{PD}}{dt} = -\frac{I_{total}}{C_{PD}}$ we can find the slope of $V_{PD}(t)$ in different time intervals. Using the slopes and our initial condition, we can also find the endpoints for each time interval.

- $t \in [0.0, 0.2]\mu\text{s}$

$$\frac{dV_{PD}}{dt} = -\frac{10^{-3}\text{A}}{10^{-9}\text{F}} = -10^6 \frac{\text{V}}{\text{s}} = -1 \frac{\text{V}}{\mu\text{s}}$$

$$V_{PD}(0) = 1\text{V}$$

$$V_{PD}(0.2\mu\text{s}) = 0.8\text{V}$$

- $t \in [0.2, 0.4]\mu\text{s}$

$$\frac{dV_{PD}}{dt} = -2 \frac{\text{V}}{\mu\text{s}}$$

$$V_{PD}(0.2\mu\text{s}) = 0.8\text{V}$$

$$V_{PD}(0.4\mu\text{s}) = 0.4\text{V}$$

We can see here that $V_{PD}(t)$ intersects $V_{REF} = 0.5\text{V}$ somewhere in this interval and use the equation below to find t_{flip} .

$$V_{PD}(0.2\mu\text{s} \leq t \leq 0.4\mu\text{s}) = V_{PD}(0.2\mu\text{s}) - 2 \frac{\text{V}}{\mu\text{s}} t V_{PD}(t_{\text{flip}}) = V_{REF}$$

to find $t_{\text{flip}} = 0.35\mu\text{s}$

- $t \in [0.4, 0.6]\mu\text{s}$

$$\frac{dV_{PD}}{dt} = 0 \frac{\text{V}}{\mu\text{s}}$$

$$V_{PD}(0.4\mu\text{s}) = 0.4\text{V}$$

$$V_{PD}(0.6\mu\text{s}) = 0.4\text{V}$$

- $t \geq 0.6\mu\text{s}$

$$\frac{dV_{PD}}{dt} = -1 \frac{\text{V}}{\mu\text{s}}$$

$$V_{PD}(0.6\mu\text{s}) = 0.4\text{V}$$

$$V_{PD}(1.0\mu\text{s}) = 0.0\text{V}$$

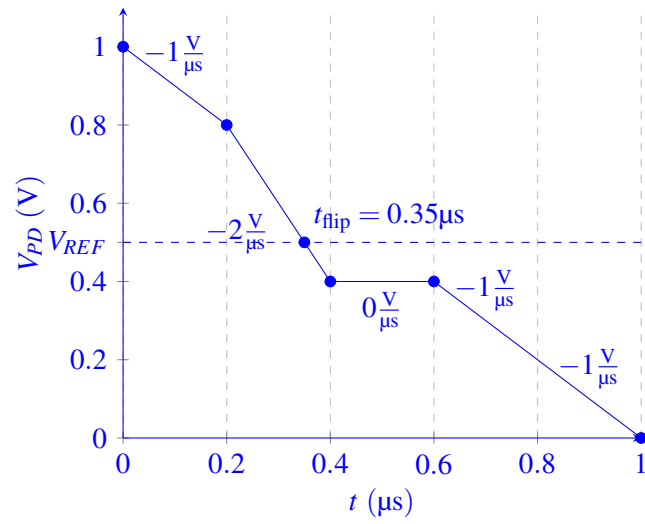

PRINT your name and student ID: _____

8. Otamatone Stars (28 points)

Your friendly lab TAs Alan and Ryan are trying to become YouTube musical sensations by playing the otamatone, which is a funny looking instrument shaped like a music note (Figure 8.1). With one hand you press your fingers to the touch pad on the stem of the otamatone, and with the other hand you squeeze open its mouth, which plays the sound corresponding to the position of your finger. As the position of your finger moves up the stem (away from the mouth) the frequency of the sound gets higher.

Instead of buying an otamatone, Ryan thinks it's cooler to build one. He has a spare "Black Box Speaker System" that takes a voltage signal input, and outputs a sound to a speaker, as shown in Figure 8.2.

All that he is missing is an input for the black box, but you notice that you can design the pad on the stem of the otamatone exactly like you designed the one-dimensional resistive touchscreen, as seen in Figure 8.3.

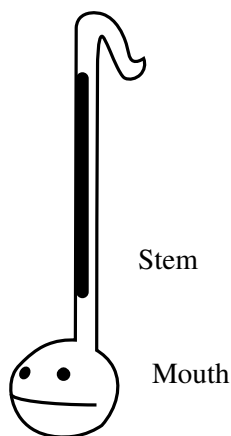

Figure 8.1: An Otamatone

You may find the following helpful:

- For Ryan's Black Box Speaker, the higher the voltage input, V_{BB} , the higher the frequency of the sound.
- The Black Box Speaker requires a minimum input voltage of $V_{BB,min} > 0$ and outputs its lowest frequency at the input voltage, $V_{BB} = V_{BB,min}$. Frequency will be higher for $V_{BB} > V_{BB,min}$.
- The darkly shaded resistive bars in Figure 8.3 are identical with a cross sectional area A , uniform resistivity ρ , and length L .
- x in Figure 8.3 indicates the position of touch.
- **We need to design an otamatone such that as we touch closer to the top ($x = L$), output sound with higher frequency is produced.**

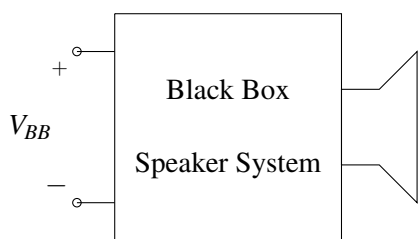

Figure 8.2: Black Box Speaker System

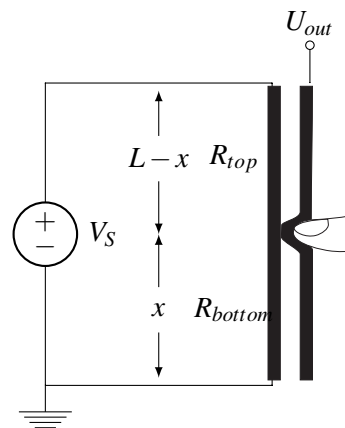

Figure 8.3: Resistive Touchscreen Schematic

PRINT your name and student ID: _____

- (a) (3 points) R_{bottom} is the resistance of the **left resistive bar** below the finger touch point x ; R_{top} is the resistance of the left resistive bar above the touch point. Find R_{bottom} and R_{top} in terms of x and other physical parameters.

Solution:

We can find both these values by simply using the equation for physical resistance: $R = \frac{\rho L}{A}$. Where L is the length of the portion and A is the area cross section.

$$R_{bottom} = \frac{\rho x}{A}$$

$$R_{top} = \frac{\rho(L-x)}{A}$$

- (b) (3 points) Find U_{out} of the touch portion of this circuit in terms of V_S , R_{top} and R_{bottom} . Show work or provide justification for your answer.

Solution:

Method 1: We can use KVL and the voltage divider equation to solve for the voltage drop over R_{top}

$$U_{out} = V_S \frac{R_{bottom}}{R_{top} + R_{bottom}}$$

Method 2: starting from scratch, you can note that the current through the circuit must be constant

$$I_0 = I_{bottom} \implies \frac{V_S}{R_{total}} = \frac{V_S}{R_{top} + R_{bottom}} = \frac{U_{out}}{R_{bottom}}$$

Which will result in the voltage divider equation above in Method 1.

- (c) (3 points) Can we directly plug our U_{out} into our black box speaker system if we want to utilize **the full range of our touchscreen**? Recall that the Black Box requires a minimum input voltage of $V_{BB,min} > 0$ to function. Justify your answer.

Solution:

No. The minimum value of U_{out} is 0V, and Ryan's black box needs at least $V_{BB,min}$

- (d) (6 points) Your discussion TAs, Rishi and Sarika, see that you are working hard on your design. To help you out, they give you the following circuit below.

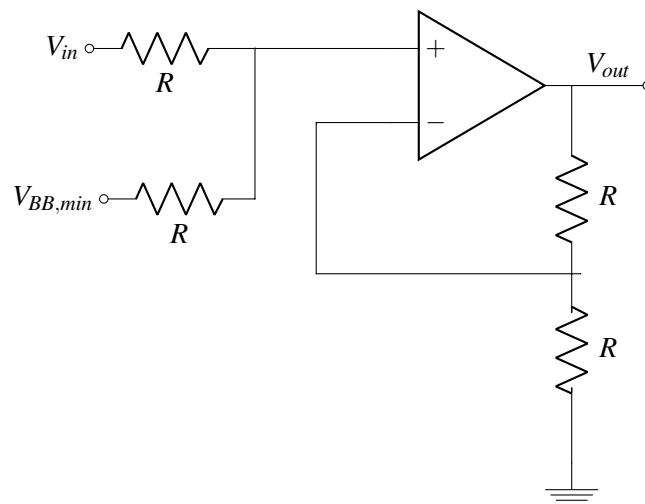

Figure 8.4: Circuit for part (d)

Find V_{out} in terms of V_{in} . What does the circuit do?

Show your work. Ignore the op-amp supply voltages for the calculations. Label any nodes you define.

Solution:

The circuit shown is a voltage summer, so $V_{out} = V_{in} + V_{BB,min}$. A full credit solution must state that the circuit is a voltage summer and give the equation for V_{out} .

It's also okay to do the nodal analysis for V_{out} . In this case, the circuit first takes the average of V_{in} and $V_{BB,min}$ and then amplifies the result by factor of 2.

- (e) (6 points) Now, complete your otamatone design! Draw the connections between the components in the figure below so that the circuit blocks function as intended. Recall that you want to increase frequency of the speaker system as you move your finger toward the top of the otamatone stem. You may use **only one additional op-amp and one additional voltage source** if needed and no other components.

Solution:

It's important to know that we can't connect anything directly to the touchscreen component, otherwise it would create extra load and change how the current will flow overall. For this reason, we can't just connect the summer to our touchscreen directly, even though it would resolve our problem in part (c). The solution is to insert a buffer between the touchscreen and then summer, which will isolate the two

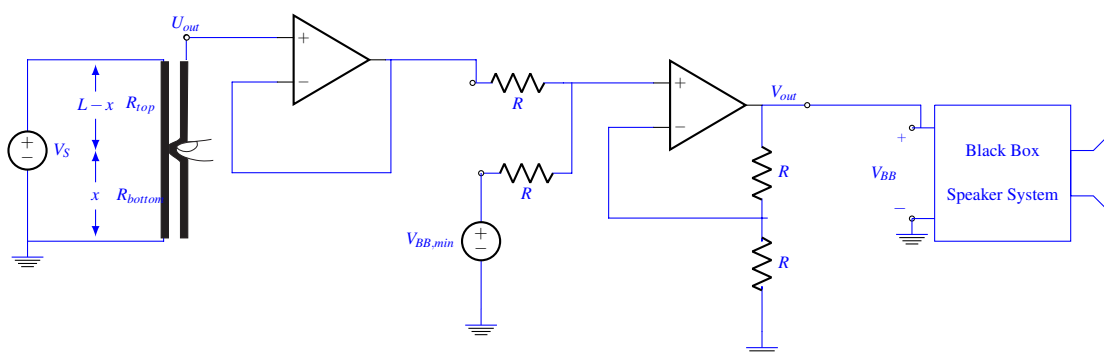

Figure 8.5: Your answer to part (e)

circuit parts. Note that no buffer is needed after the summer since V_{out} is after an op amp already.

The full circuit will look like such: [Touchscreen] + [Buffer] + [Summer/Amp] + [BB Circuit]

- (f) (6 points) Using your design from Figure 8.5, find your V_{BB} , the signal going into the black box speaker system, as a function of x , the location of touch on the touch bar.

Solution:

Again, show work for full points.

Our touchscreen output and our summer circuit have the V_{out} expressions:

$$U_{out} = V_S \frac{x}{L}, V_{out} = V_{BB,min} + V_{in}$$

Since we have fed the output of the touchscreen circuit through a buffer already, we can now plug in U_{out} for V_{in} :

$$V_{out} = V_{BB,min} + U_{out}$$

$$V_{out} = V_{BB,min} + V_S \frac{x}{L}$$

And since we will feed V_{out} from the summer circuit into the black box, our V_{BB} expression is:

$$V_{BB} = V_{BB,min} + V_S \frac{x}{L}$$

- (g) (1 point) Would you hit like, comment, and subscribe on Alan's YouTube channel? (*This is a fun question! Any answer will receive full credit.*)

Solution:

Full points awarded for any answer.