

# EECS 16A Designing Information Devices and Systems I

## Spring 2022 Homework 11

**This homework is due November 12, 2021, at 23:59.**

**Self-grades are due November 15, 2021, at 23:59.**

### Submission Format

Your homework submission should consist of **one** file.

- `hw11.pdf`: A single PDF file that contains all of your answers (any handwritten answers should be scanned)

Submit each file to its respective assignment on Gradescope.

### 1. Reading Assignment

For this homework, please read Notes 18 and 19. They will provide an overview on operational amplifiers (op-amps), negative feedback, the "golden rules" of op-amps, and various op-amp configurations (non-inverting, inverting, buffers, etc). You are always encouraged to read beyond this as well.

- What are the two "golden rules" of ideal op-amps? When do these rules hold true?
- What does the internal gain of an op-amp,  $A$ , mean? What is its value for an ideal op-amp? What about for a non-ideal one?

### 2. Basic Amplifier Building Blocks

The following amplifier stages are used often in many circuits and are well known as (a) the non-inverting amplifier and (b) the inverting amplifier.

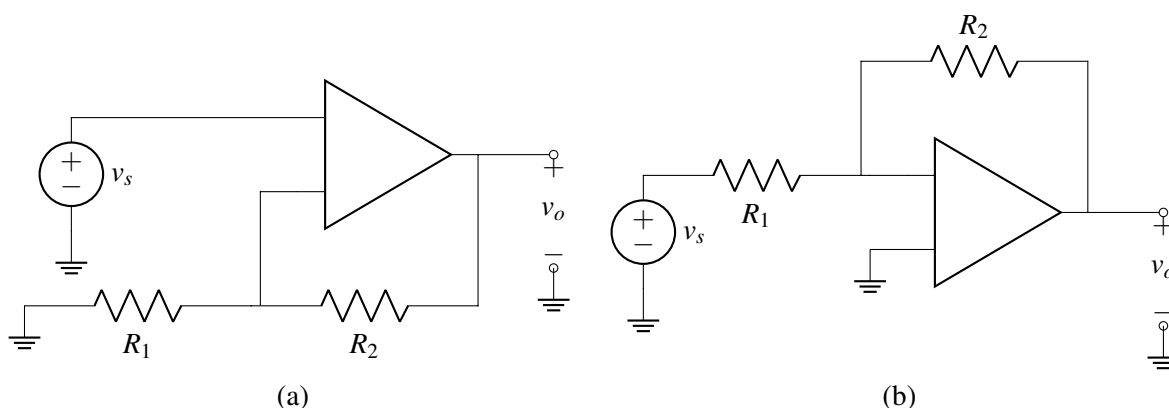

- Label the input terminals of the op-amp with (+) and (-) signs in Figure (a), so that it is in negative feedback. Then derive the voltage gain ( $G = \frac{v_o}{v_s}$ ) of the non-inverting amplifier in Figure (a) using the Golden Rules. Why do you think this circuit is called a non-inverting amplifier?

- (b) Label the input terminals of the op-amp with (+) and (-) signs in Figure (b), so that it is in negative feedback. Then derive the voltage gain ( $G = \frac{v_o}{v_s}$ ) of the inverting amplifier using the Golden Rules. Can you explain why this circuit is called an inverting amplifier?
- (c) Using your toolkit of circuit topologies, design blocks that implement the following equations. Feel free to reference Discussion 10B for circuit topologies:
- $v_o = 2v_s$
  - $v_o = -3v_s + 8$

### 3. Amplifier with Multiple Inputs

- (a) Use the Golden Rules to find  $v_{o1}$  for the circuit below.

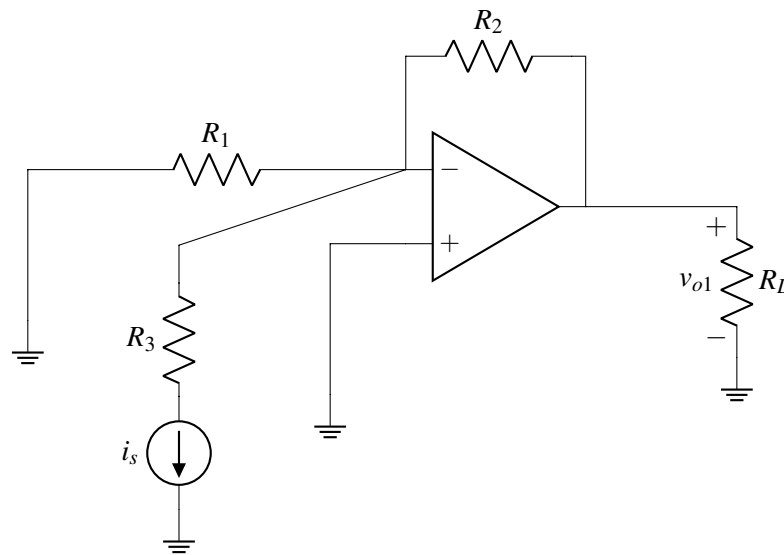

- (b) Use the Golden Rules to find  $v_{o2}$  for the circuit below.

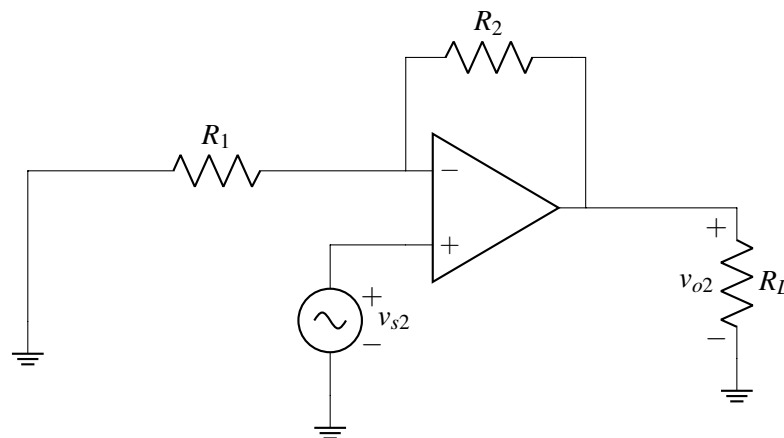

- (c) Use the Golden Rules to find the output voltage  $v_o$  for the circuit shown below.

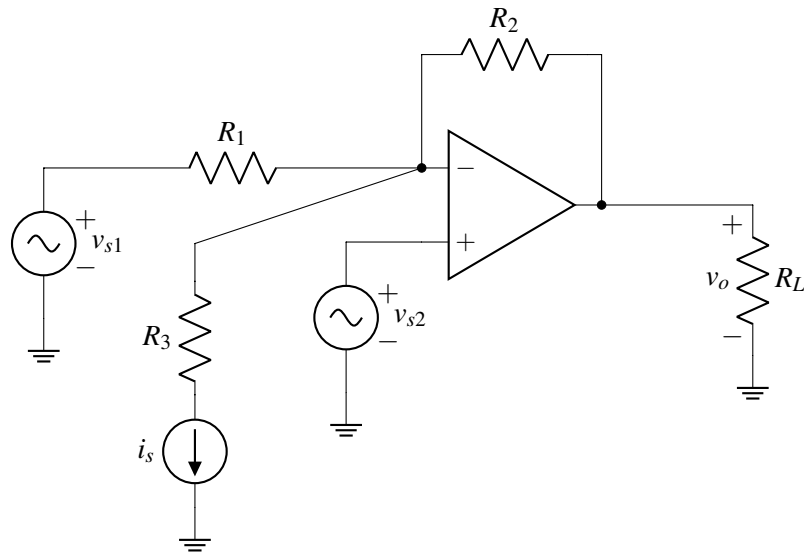

- (d) Use superposition and the answers to the first few parts of this problem to verify your answer to part c. *Hint: See if you can generate some combination of the circuits in a & b that is equivalent to the one in c.*
- (e) Now add a second stage as shown below. What is  $v_{o,new}$ ? Does  $v_o$  change between part (c) and this part? Does the voltage  $v_{o,new}$  depend on  $R_L$ ?

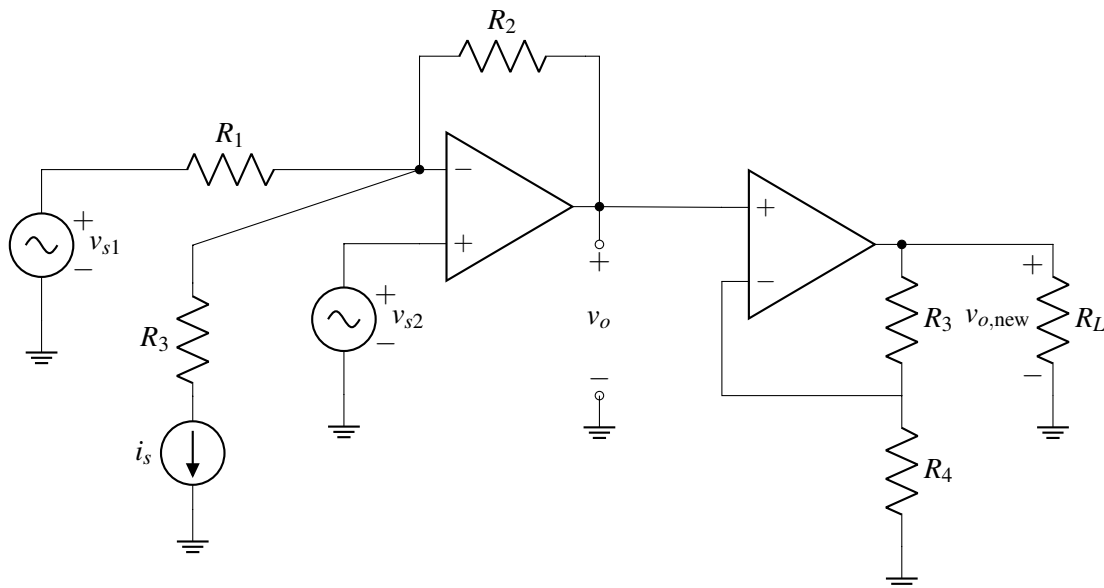

#### 4. Cool For The Summer

You and a friend want to make a box that helps control an air conditioning unit based on both your inputs. You both have individual dials which you can use to control the voltage. An input of 0 V means that you want to leave the temperature as is. A **negative voltage input** means that you want to **reduce** the temperature. (It's hot out, so we will assume that you never want to increase the temperature – so no, we're not talking about a Berkeley summer...)

Your air conditioning unit, however, responds only to **positive voltages**. The higher the magnitude of the voltage, the stronger it runs. At zero, it is off. You also need a system that **sums up** both you and your friend's control inputs.

Therefore, you need a box that acts as an **an inverting summer** – it outputs a weighted sum of two voltages where the weights are both negative. The sum is weighted because one room is bigger, so you need to compensate for this.

- (a) As a first step, derive  $v_{out}$  in terms of  $R_2$ ,  $R_1$ , and  $v_{in}$ .

*Hint: Have you solved for this particular amplifier configuration before? You can use your answer from the time you did this earlier.*

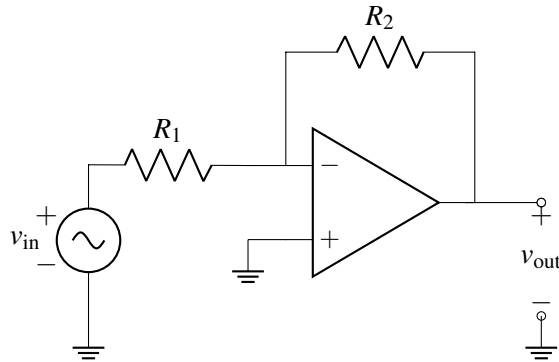

- (b) Now we will add a second input to this circuit as shown below. Find  $v_{out}$  in terms of  $v_{S1}$ ,  $v_{S2}$ ,  $R_{S1}$ ,  $R_{S2}$  and  $R_2$ .

*Hint: You can solve this problem using either superposition or our tried-and-true KCL analysis.*

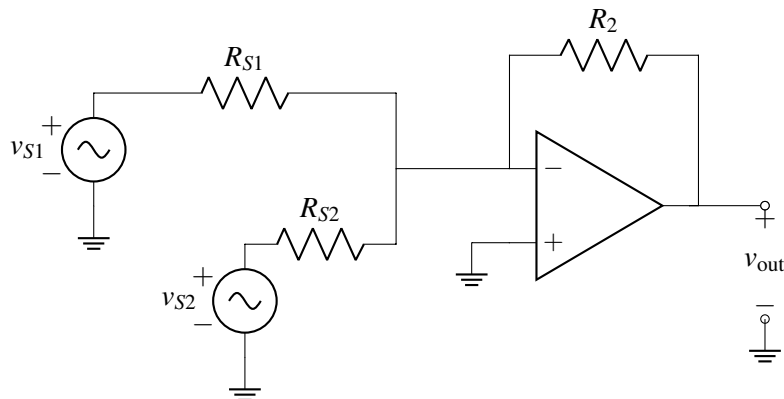

- (c) Let's suppose that you want  $v_{out} = -\left(\frac{1}{4}v_{S1} + 2v_{S2}\right)$  where again  $v_{S1}$  and  $v_{S2}$  represent the input voltages from you and your friend's control knobs. Select resistor values such that the circuit from part (b) implements this desired relationship.
- (d) Suppose that you have a new AC unit that you want to use with your original control inputs  $v_{S1}$  and  $v_{S2}$ . **This unit, however, responds only to negative voltages – the opposite of your previous air conditioning unit, which only responded to positive input voltages.** The higher the magnitude of the negative voltage, the stronger the AC runs. You want to modify your prior circuit for the new AC unit. Your circuit takes in two control voltages and outputs a weighted sum, but the sum should now become more negative as you increase your input voltages.

*Hint: Consider adding another op-amp circuit to the output of your circuit from part (b), such that you invert the output of the op-amp circuit of part (b) **without** adding additional gain.*

## 5. Putting on the Pressure: Build Your Own InstantPot

Prof. Arias had a great experience with her automatic pressure cooker, so she was inspired to try and build her own. She's enlisting your help! The design of the pressure cooker uses a pressure sensor and a heating element. Whenever the pressure is below a set target value, an electronic circuit turns on the heating element.

### Pressure Sensor Resistance

The first step is designing a pressure sensor. The figure below shows your design. As pressure  $p_c$  is applied, the flexible membrane stretches.

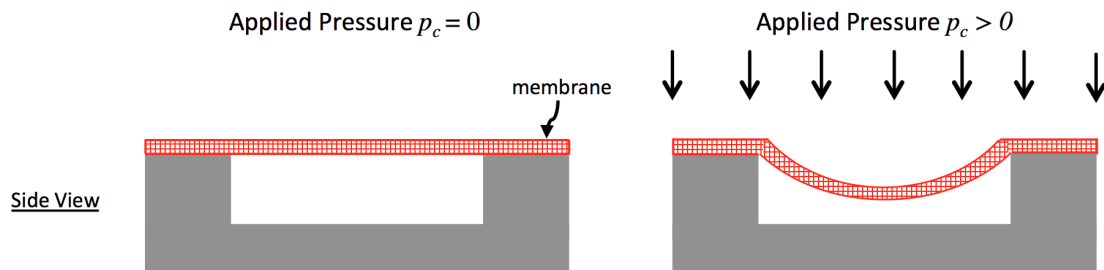

- (a) You attach a resistor layer  $R_p$  with resistivity  $\rho = 0.1 \Omega\text{m}$ , width  $W$ , length  $L$ , and thickness  $t$  to the pressure sensor membrane, as illustrated in the figure below. When the pressure  $p_c = 0 \text{ Pa}$  (i.e. there is no applied pressure),  $W = 1 \text{ mm}$ ,  $L = L_0 = 1 \text{ cm}$ ,  $t = 100 \mu\text{m} = 100 \times 10^{-6} \text{ m}$ .

$R_{p0}$  is the value of  $R_p$  when there is no applied pressure. Calculate  $R_{p0}$ . Note that direction of current flow in the resistor is from A to B as marked in the diagram.

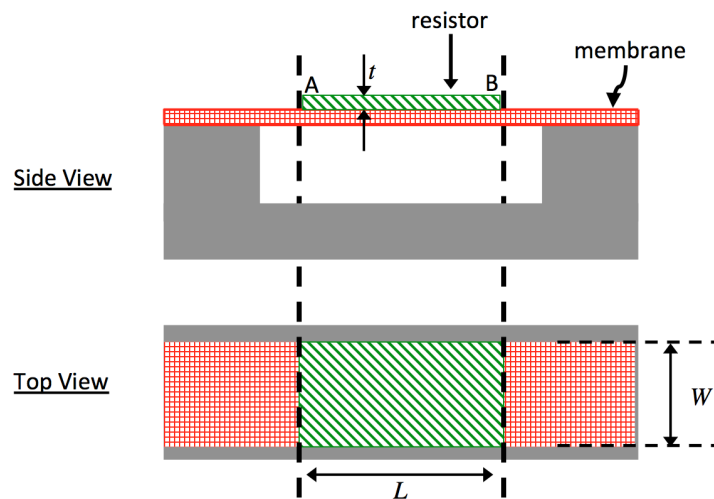

- (b) When pressure is applied, the length of the resistor  $L$  changes from  $L_0$  and is a function of applied pressure  $p_c$ , and is given by

$$L = L_0 + \beta p_c,$$

where  $L_0$  is the nominal length of the resistor with no pressure applied, and  $\beta$  is a constant with units  $\text{m}/\text{Pa}$ . As a result of the length change, the value of resistance  $R_p$  also changes from its nominal value  $R_{p0}$  (the value of  $R_p$  with no pressure applied).

**Derive an expression for  $R_p$  as a function of resistivity  $\rho$ , width  $W$ , thickness  $t$ , nominal length  $L_0$ , constant  $\beta$ , and applied pressure  $p_c$ , when pressure is applied.**

*Note:* The width and thickness of the resistor will also change with applied pressure. However, we ignore this to keep the math simple.

**(c) Pressure Sensor Circuit Design**

For this sub-part and the following sub-parts, we will use a new model for pressure-sensitive resistance  $R_p$ . Assume that the resistance  $R_p$  is a function of applied pressure  $p_c$  according to the relationship  $R_p = R_o \times \frac{p_c}{p_{\text{ref}}}$ , where  $R_o = 1\text{k}\Omega$ , and  $p_{\text{ref}} = 100\text{kPa}$ .

To complete our sensor circuit, we would like to generate a voltage  $V_p$  that is a function of the pressure  $p_c$ .

**Complete the circuit below so that the output voltage  $V_p$  depends on the pressure  $p_c$  as:**

$$V_p = -V_o \times \frac{p_c}{p_{\text{ref}}}, \text{ where } V_o = 1 \text{ V.}$$

Restrictions on your pressure sensor circuit design are as follows:

- **You may add at most one ideal voltage source and one additional resistor besides  $R_p$  to the circuit, but you must calculate their values and mark them in the diagram.**
- **Mark the positive and negative inputs of the operational amplifier with “+” and “-” symbols, respectively, in the boxes provided.**
- **Assume op-amp supply voltages  $V_{DD}$  and  $V_{SS} = -V_{DD}$  are already provided.**

You may assume that the operational amplifier is ideal.

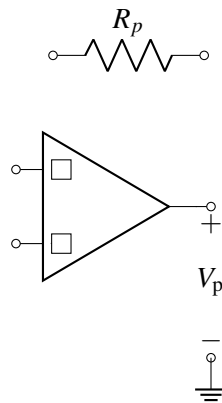

**(d) Resistive Heating Element**

To heat the pressure cooker, you use a heating element with resistance  $R_{\text{heat}}$ . Calculate the value of  $R_{\text{heat}}$  such that the power dissipated is  $P_{\text{heat}} = 1000\text{W}$  with  $V_{\text{heat}} = 100\text{V}$  applied across the heating element.

**(e) Pressure Regulation**

You are finally ready to complete the design of your pressure cooker.

**Using all of the circuit elements below, make a circuit that will turn the heater on (i.e. will cause a current to flow through  $R_{\text{heat}}$ ) when the pressure is less than 500 kPa, and off (i.e. will cause no current to flow through  $R_{\text{heat}}$ ) when the pressure is greater than 500 kPa.**

The elements are:

- A voltage source  $V_s = 10\text{V}$  in series with a resistance of  $500\Omega$ .

- A dependent voltage source  $V_p = V_o \times \frac{p_c}{p_{\text{ref}}}$ , with  $V_o = 1\text{V}$  and  $p_{\text{ref}} = 100\text{kPa}$ . (This is a voltage source whose voltage is a function of pressure  $p_c$ , unrelated to any previous parts of the question.)
- A comparator that controls switch  $S_0$ . The switch is normally opened (i.e. an open circuit between nodes  $V_a$  and  $V_b$ ), and is closed only when  $V_1 > V_2$  (i.e. a short circuit between nodes  $V_a$  and  $V_b$ ).
- The heater supply ( $V_{\text{heat}} = 100\text{V}$ ).
- The heater resistor  $R_{\text{heat}}$ .
- One additional resistor  $R_{\text{extra}}$  that can have **any value**.
- Assume comparator supply voltages  $V_{DD}$  and  $V_{SS} = -V_{DD}$  are already provided.

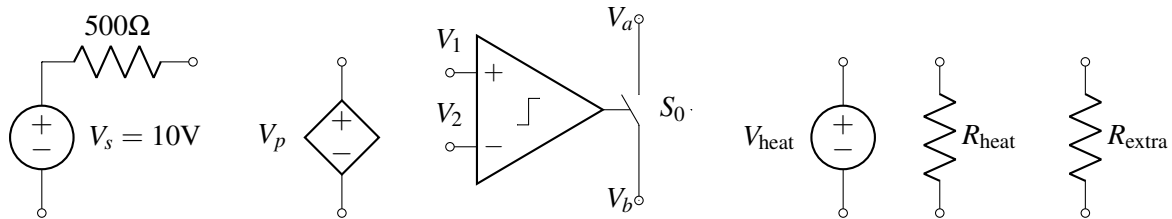

## 6. Homework Process and Study Group

Who did you work with on this homework? List names and student ID's. (In case you met people at homework party or in office hours, you can also just describe the group.) How did you work on this homework? If you worked in your study group, explain what role each student played for the meetings this week.