EECS 16A Imaging 1

Insert your names here

DSP Accommodations

- If you need any DSP accommodations (lab-specific or general class-related), please make sure your accommodation letter has been submitted.
- If you need anything further regarding lab, please reach out to Anastasia and Shreyash at the lab email: eeecs16a.lab@berkeley.edu

Pre-Lab Reading

- Pre-Lab Readings are short, 1-2 page readings that will introduce a bit of theory as well as act as a review of what you have seen in class and labs in previous weeks. Readings for each lab can be found on the course website.
- Pre-Lab readings are mandatory and are a part of that week's HW (the week that it is released).
- Imaging 1's reading is not part of any HW!

Semester Outline



Imaging
Module



Touchscreen
Module



Acoustic
Positioning
Module

Why Imaging?

- Use linear algebra techniques to capture real world images with limited sensors
- Today:
 - Finding a link between physical quantities and voltage
 - If you can digitize it, you can do anything (IOT devices, internet, code, processing)

Today's Lab: Imaging Part 1

- You'll receive lab kit materials after completing part 1 of today's lab (TI MSP430F5529 + lab kit)
- Circuits + Breadboarding 101
- Build circuit that reacts to light intensity
 - Use Launchpad (+ Oscilloscope) to see how the circuit behaves
- **Graded checkoff starts today!**

Our circuit

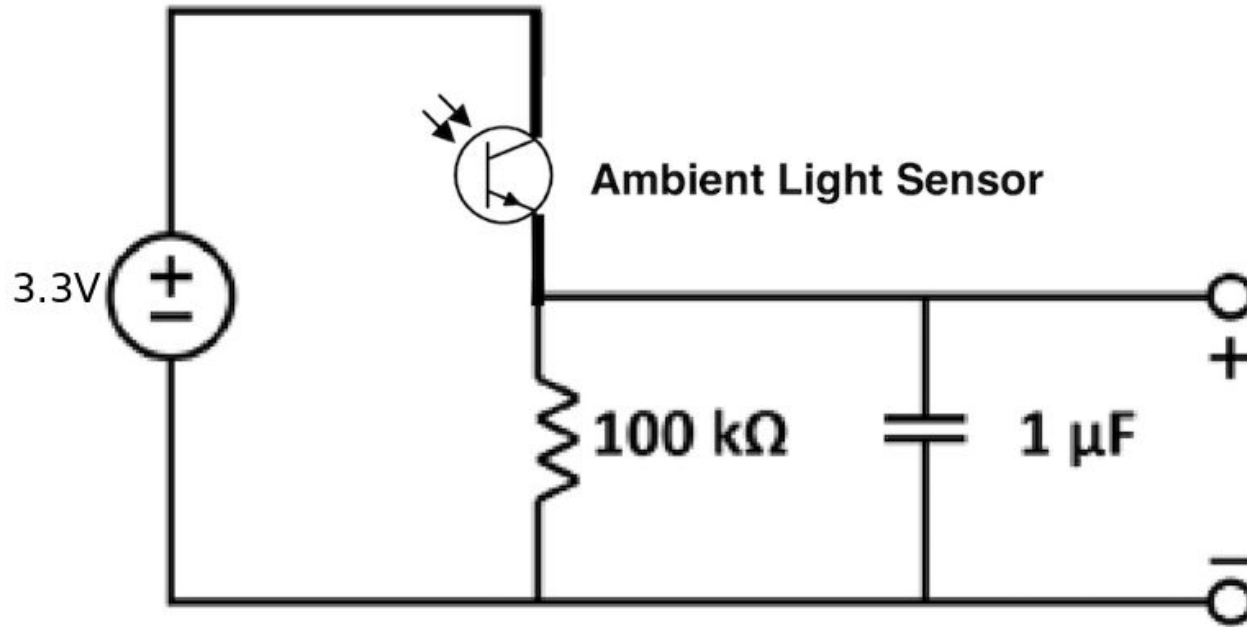

A Little Physics: Voltage, Current, and Resistors

- **Voltage [Volts]** - electric “pressure” that pushes charge through circuit
- **Current [Amps]** - flow of charge through circuit
 - 1 Amp = 1 Coulomb per second =
- **Resistor [Ohms]** - circuit component that resists the flow of charge through circuit

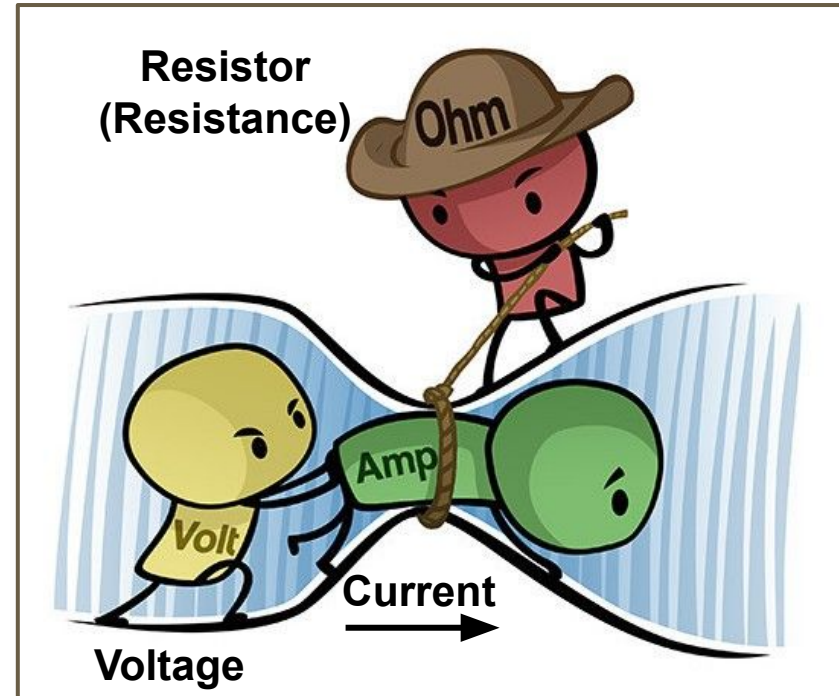

Simple Circuit: The Tools™

- Components
 - Resistors
 - Capacitors
 - Voltage Source
- Wires / Jumpers [pin-to-pin vs pin-to-socket]

What's in your circuit? : Resistors

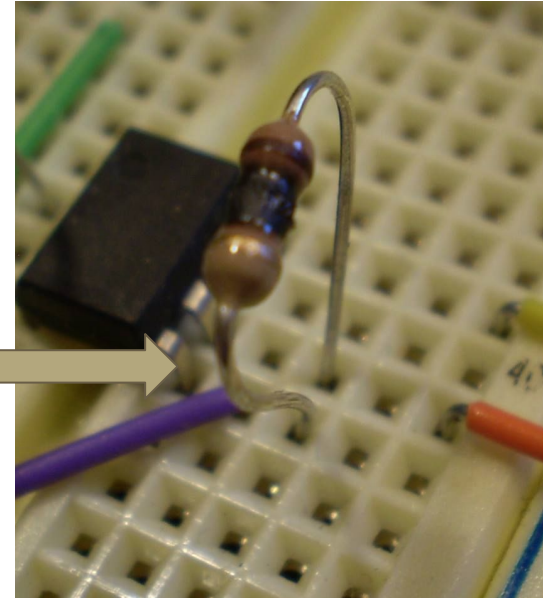
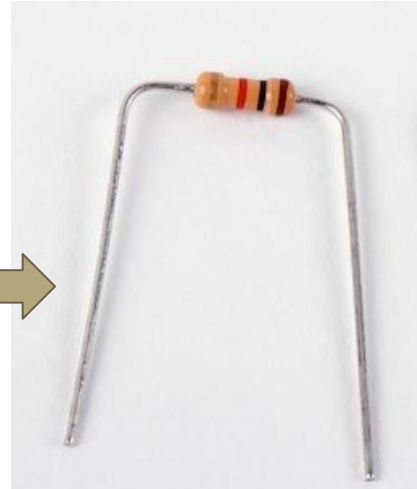

What's on your circuit? : Resistors



4 Band Resistor Color Coding

COLOR	1ST BAND	2ND BAND	MULTIPLIER	TOLERANCE
BLACK	0	0	x1 Ω	
BROWN	1	1	x10 Ω	$\pm 1\%$
RED	2	2	x100 Ω	$\pm 2\%$
ORANGE	3	3	x1000 Ω	
YELLOW	4	4	x10000 Ω	
GREEN	5	5	x100000 Ω	$\pm 0.5\%$
BLUE	6	6	x1000000 Ω	$\pm 0.25\%$
VIOLET	7	7	x10000000 Ω	$\pm 0.10\%$
GREY	8	8		$\pm 0.05\%$
WHITE	9	9		
GOLD			0.1	$\pm 5\%$
SILVER			0.01	$\pm 10\%$

What's on your circuit? : Resistors



4 Band Resistor Color Coding



COLOR	1ST BAND	2ND BAND	MULTIPLIER	TOLERANCE
BLACK	0	0	x1 Ω	
BROWN	1	1	x10 Ω	$\pm 1\%$
RED	2	2	x100 Ω	$\pm 2\%$
ORANGE	3	3	x1000 Ω	
YELLOW	4	4	x10000 Ω	
GREEN	5	5	x100000 Ω	$\pm 0.5\%$
BLUE	6	6	x1000000 Ω	$\pm 0.25\%$
VIOLET	7	7	x10000000 Ω	$\pm 0.1\%$
GREY	8	8		$\pm 0.05\%$
WHITE	9	9		
GOLD			0.1	$\pm 5\%$
SILVER			0.01	$\pm 10\%$

Difficult to see on projector:
this says "x1 Ω ", not "x10"

Poll Time! What color is a 100 ohm resistor?

4 Band Resistor Color Coding



COLOR	1ST BAND	2ND BAND	MULTIPLIER	TOLERANCE
BLACK	0	0	x1 Ω	
BROWN	1	1	x10 Ω	$\pm 1\%$
RED	2	2	x100 Ω	$\pm 2\%$
ORANGE	3	3	x1000 Ω	
YELLOW	4	4	x10000 Ω	
GREEN	5	5	x100000 Ω	$\pm 0.5\%$
BLUE	6	6	x1000000 Ω	$\pm 0.25\%$
VIOLET	7	7	x10000000 Ω	$\pm 0.10\%$
GREY	8	8		$\pm 0.05\%$
WHITE	9	9		
GOLD			0.1	$\pm 5\%$
SILVER			0.01	$\pm 10\%$

1. black-brown-red
2. brown-black-brown
3. brown-black-red
4. brown-black-black

Poll Time! What color is a 100 ohm resistor?



4 Band Resistor Color Coding

COLOR	1ST BAND	2ND BAND	MULTIPLIER	TOLERANCE
BLACK	0	0	x1 Ω	
BROWN	1	1	x10 Ω	$\pm 1\%$
RED	2	2	x100 Ω	$\pm 2\%$
ORANGE	3	3	x1000 Ω	
YELLOW	4	4	x10000 Ω	
GREEN	5	5	x100000 Ω	$\pm 0.5\%$
BLUE	6	6	x1000000 Ω	$\pm 0.25\%$
VIOLET	7	7	x10000000 Ω	$\pm 0.10\%$
GREY	8	8		$\pm 0.05\%$
WHITE	9	9		
GOLD			0.1	$\pm 5\%$
SILVER			0.01	$\pm 10\%$

1. black-brown-red
- 2. brown-black-brown**
3. brown-black-red
4. brown-black-black

Poll Time! What color is a 100K resistor? (100 kilo-ohms, so 100,000 ohms)



4 Band Resistor Color Coding



COLOR	1ST BAND	2ND BAND	MULTIPLIER	TOLERANCE
BLACK	0	0	$\times 1\Omega$	
BROWN	1	1	$\times 10\Omega$	$\pm 1\%$
RED	2	2	$\times 100\Omega$	$\pm 2\%$
ORANGE	3	3	$\times 1000\Omega$	
YELLOW	4	4	$\times 10000\Omega$	
GREEN	5	5	$\times 100000\Omega$	$\pm 0.5\%$
BLUE	6	6	$\times 1000000\Omega$	$\pm 0.25\%$
VIOLET	7	7	$\times 10000000\Omega$	$\pm 0.10\%$
GREY	8	8		$\pm 0.05\%$
WHITE	9	9		
GOLD			0.1	$\pm 5\%$
SILVER			0.01	$\pm 10\%$

1. brown-black-red
2. brown-black-brown
3. brown-black-yellow
4. brown-black-white

Poll Time! What color is a 100K resistor? (100 kilo-ohms, so 100,000 ohms)



4 Band Resistor Color Coding

COLOR	1ST BAND	2ND BAND	MULTIPLIER	TOLERANCE
BLACK	0	0	x1 Ω	
BROWN	1	1	x10 Ω	$\pm 1\%$
RED	2	2	x100 Ω	$\pm 2\%$
ORANGE	3	3	x1000 Ω	
YELLOW	4	4	x10000 Ω	
GREEN	5	5	x100000 Ω	$\pm 0.5\%$
BLUE	6	6	x1000000 Ω	$\pm 0.25\%$
VIOLET	7	7	x10000000 Ω	$\pm 0.10\%$
GREY	8	8		$\pm 0.05\%$
WHITE	9	9		
GOLD			0.1	$\pm 5\%$
SILVER			0.01	$\pm 10\%$

1. brown-black-red
2. brown-black-brown
- 3. brown-black-yellow**
4. brown-black-white

Light Emitting Diode (LED)

When a sufficient potential difference is placed across its terminals, the LED emits light!

Direction matters!

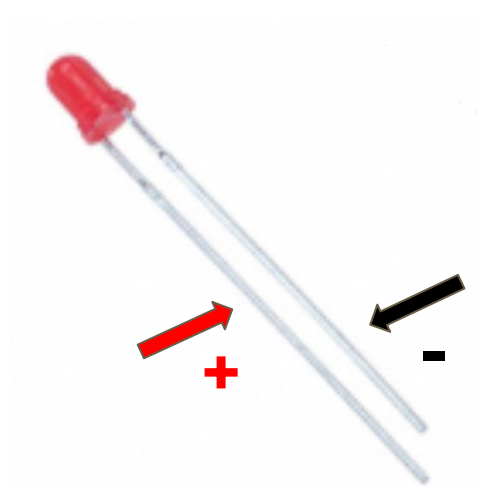

Ambient Light Sensor



It behaves like a resistor and the current passing through it depends on how much light there is around it!

Direction matters! **Note: Polarity is opposite LED's**

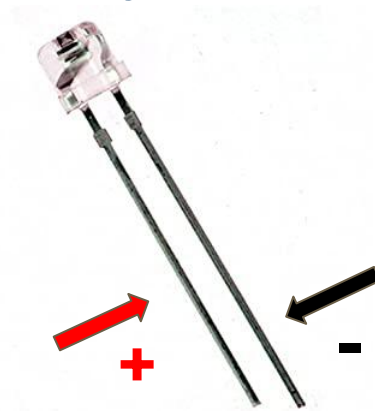

Capacitors

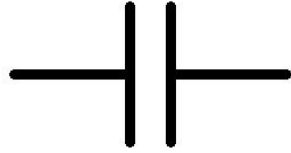

They store your charge!
Called capacitors because
they have a set capacity (in
Farads)

Wires/Jumpers

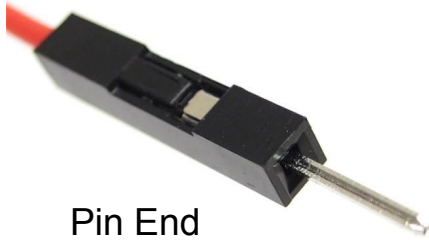

Pin End

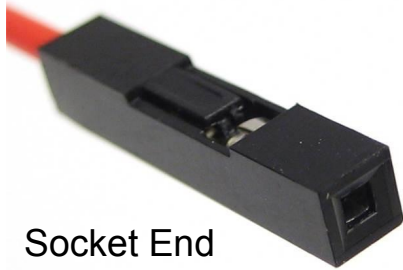

Socket End



IMPORTANT: we use pin/socket terminology for wiring. You may encounter male/female in documentation or in industry.

Voltage Source

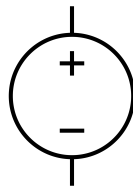

IMPORTANT: Always keep current limited @ 0.1 A limit

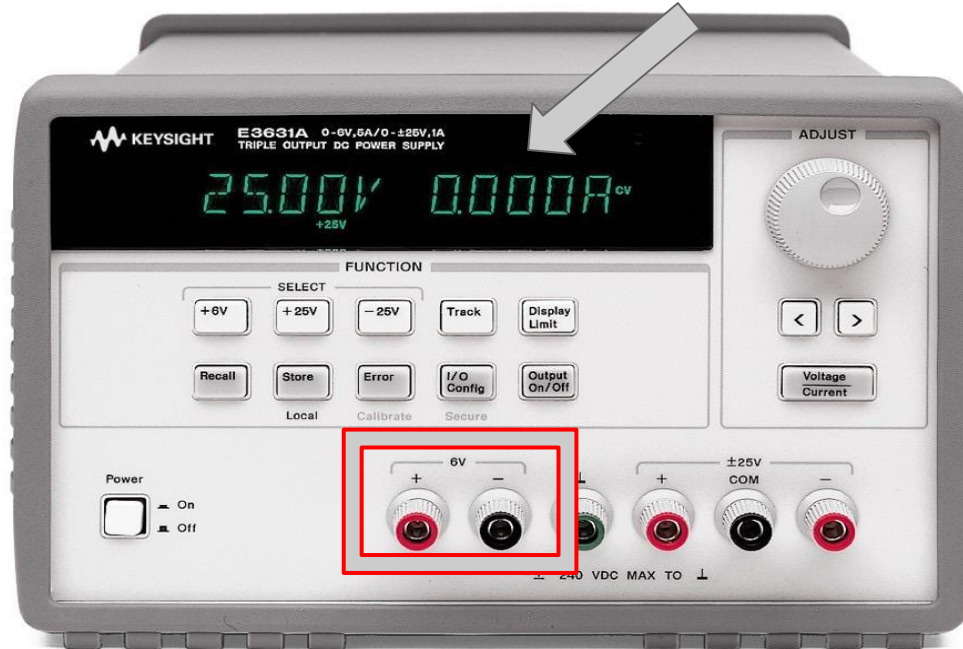

PSU cables are hanging on back wall

Voltage Source

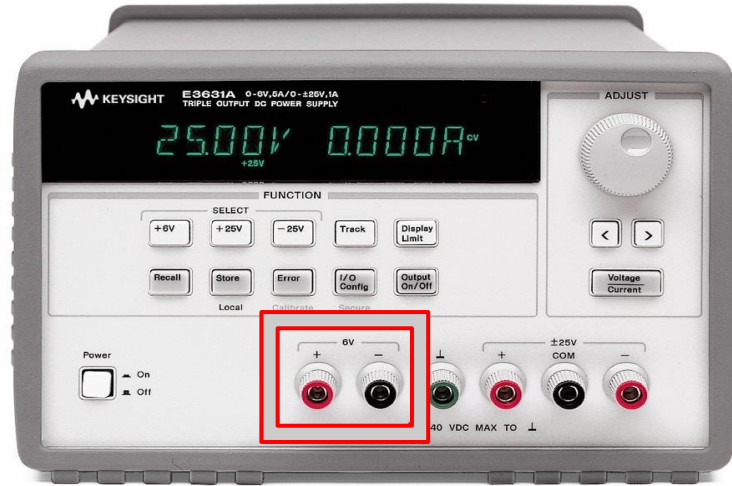
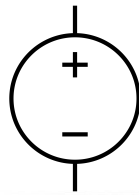

Power Supply Unit (PSU)

We will be using the LaunchPad as well as the PSU as our voltage source. The 3V3 and GND pins on the LaunchPad are the + and - terminals of the voltage source respectively

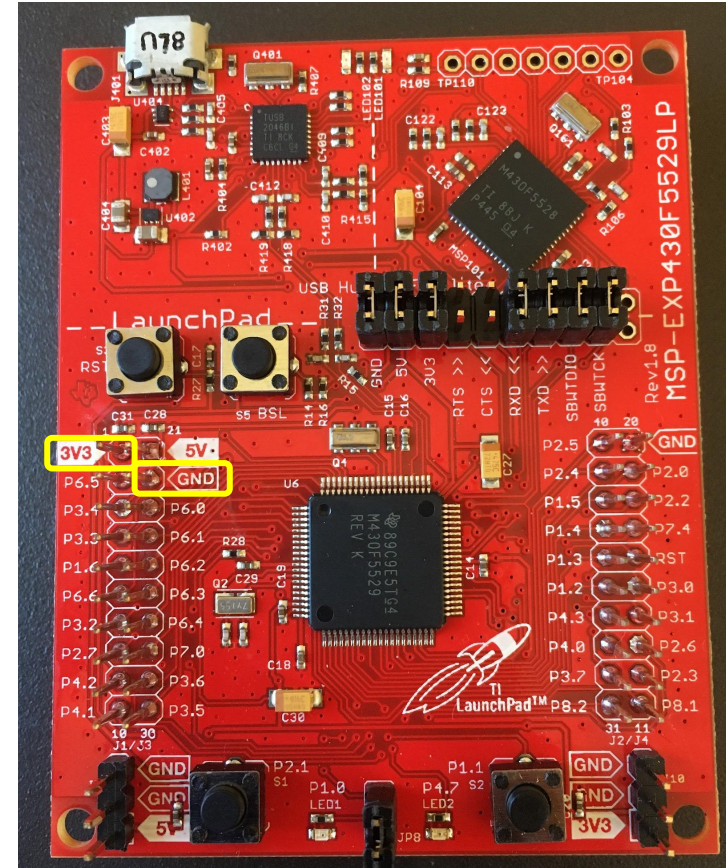

Simple Circuit: The Theory

- Components
- Nodes
 - Point in circuit where circuit elements meet
 - Wire between components are considered part of one node
- We know you don't know much about circuits yet; we've given you very detailed instructions on how to build the circuit in the lab

Simple Circuit: The Theory™

- Components (Resistors, LEDs, Capacitors)
- Nodes
 - Point in circuit where circuit elements meet
 - Wire between components are considered part of one node



What components?

How many nodes?

Where are these nodes?

Simple Circuit: The Theory™

- Components (Resistors, LEDs, Capacitors)
- Nodes
 - Point in circuit where circuit elements meet
 - Wire between components are considered part of one node

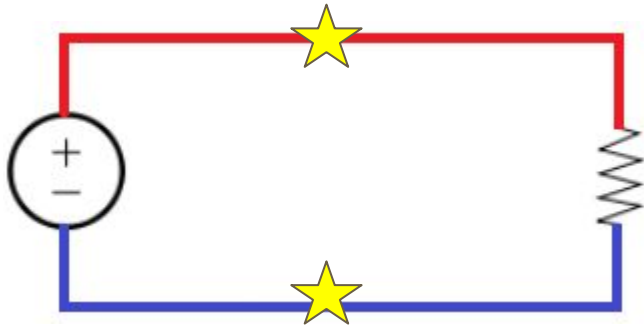

What components?

Voltage source, resistor

How many nodes? **2**

Where are these nodes?

Simple Circuit: The Theory™

- Components (Resistors, LEDs, Capacitors)
- Nodes
 - Point in circuit where circuit elements meet
 - Wire between components are considered part of one node

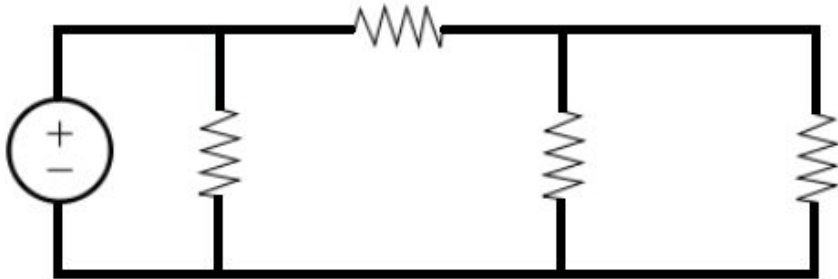

What components?

How many nodes?

Where are these nodes?

Simple Circuit: The Theory™

- Components (Resistors, LEDs, Capacitors)
- Nodes
 - Point in circuit where circuit elements meet
 - Wire between components are considered part of one node

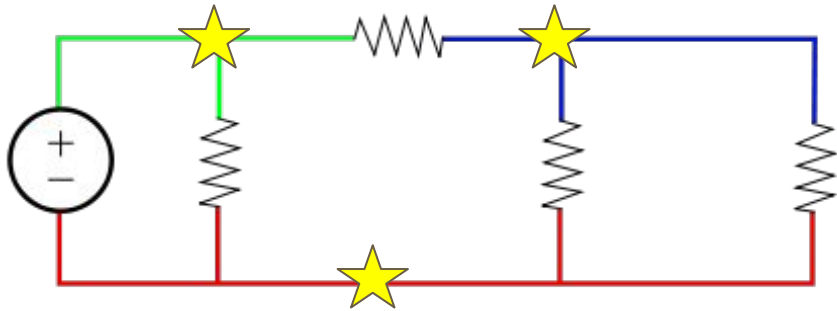

What components? **Same**

How many nodes? **3**

Where are these nodes?

Breadboard

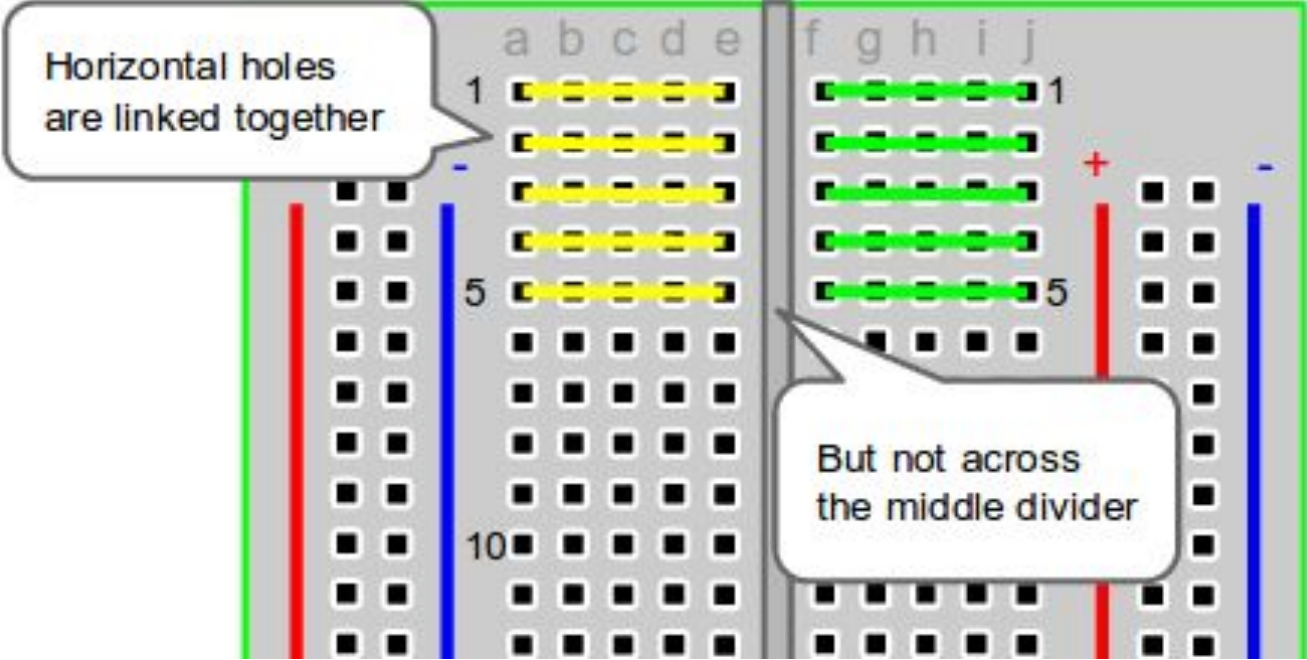

Breadboard

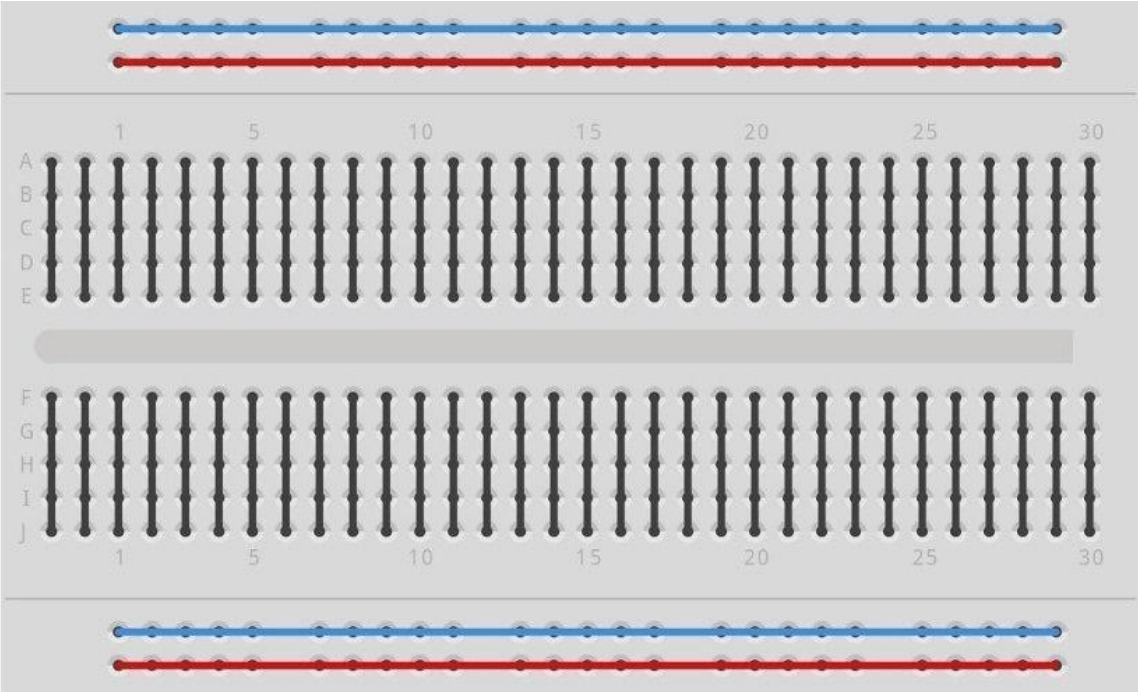

Breadboard Do's and Don't's

- ✓ **Do** plug component's ends into two different rows - separate nodes

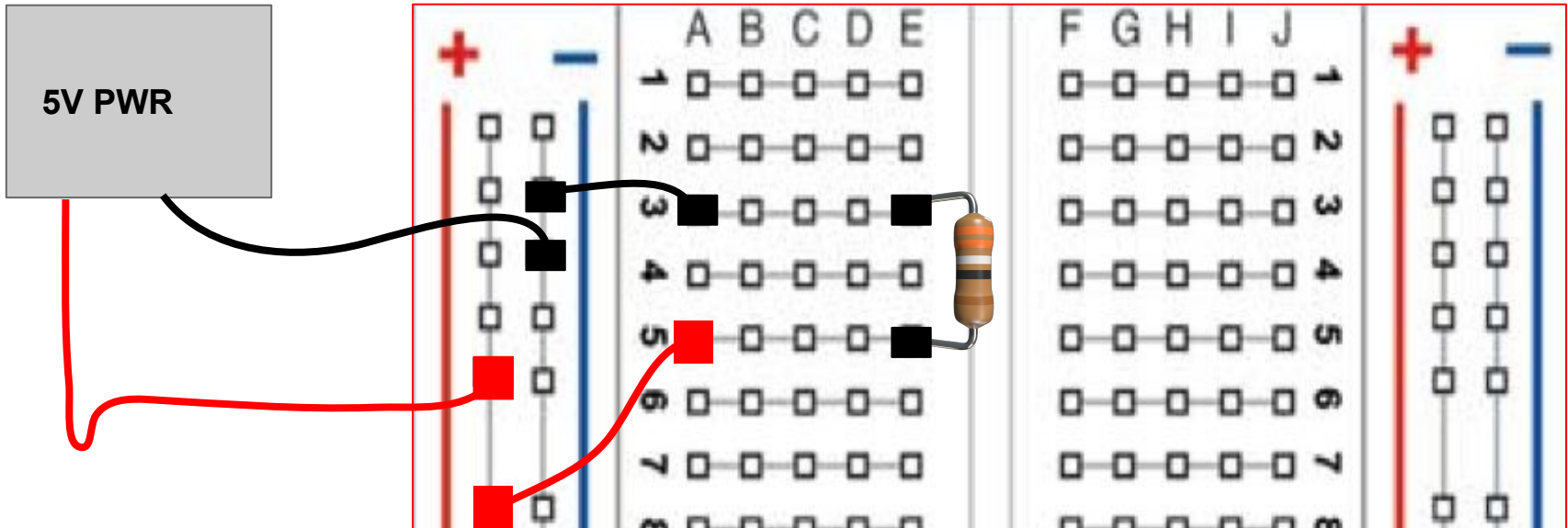
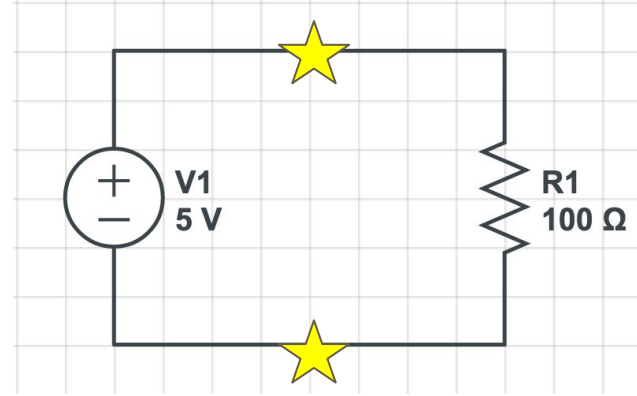

Breadboard Do's and Don't's

- ✓ **Do** plug components across the gap in your breadboard - A-E and F-J are separate

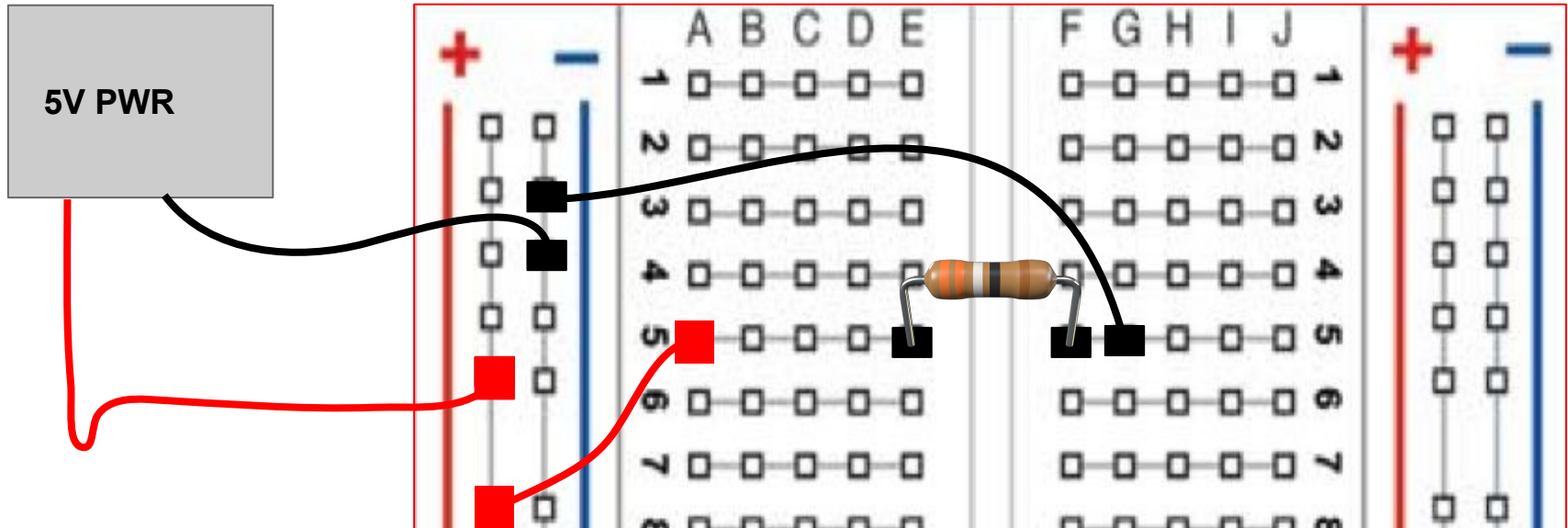
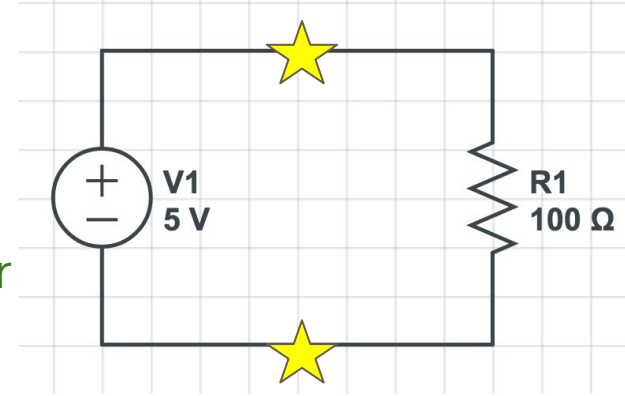

Breadboard Do's and Don't's

Is this okay? If there is an error, where?

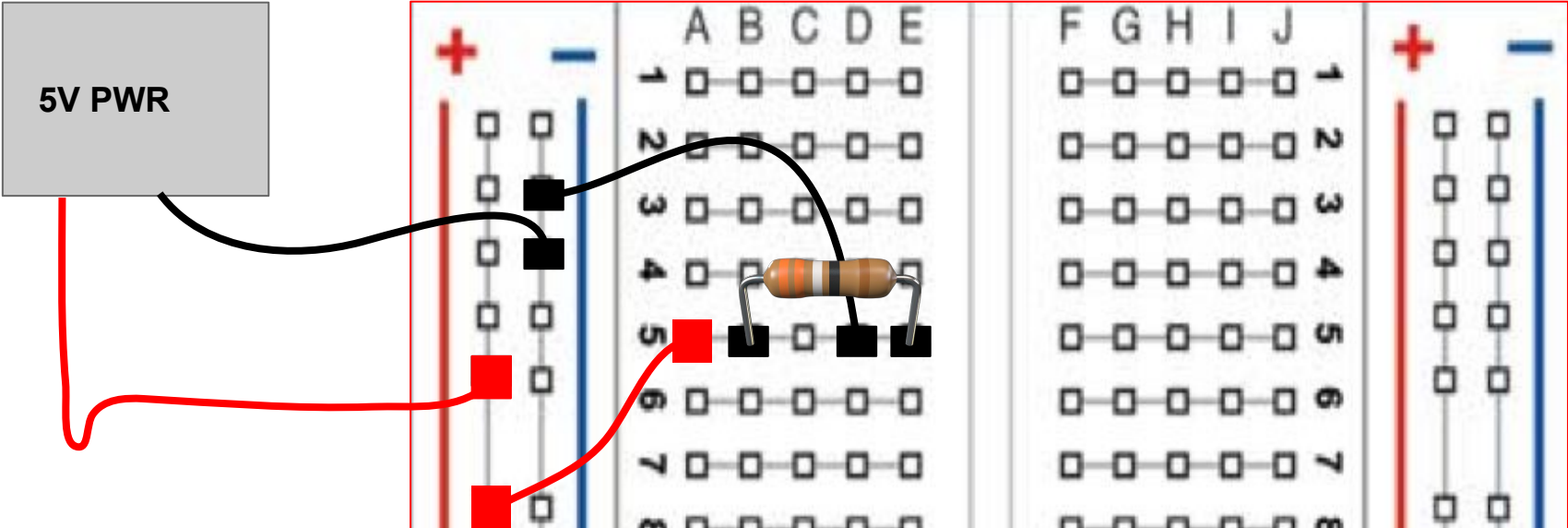
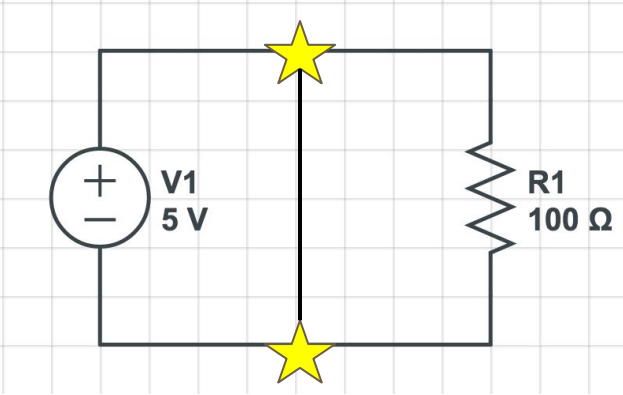

Breadboard Do's and Don't's

✗ **Do not** plug both ends of component into the same row! This creates a short

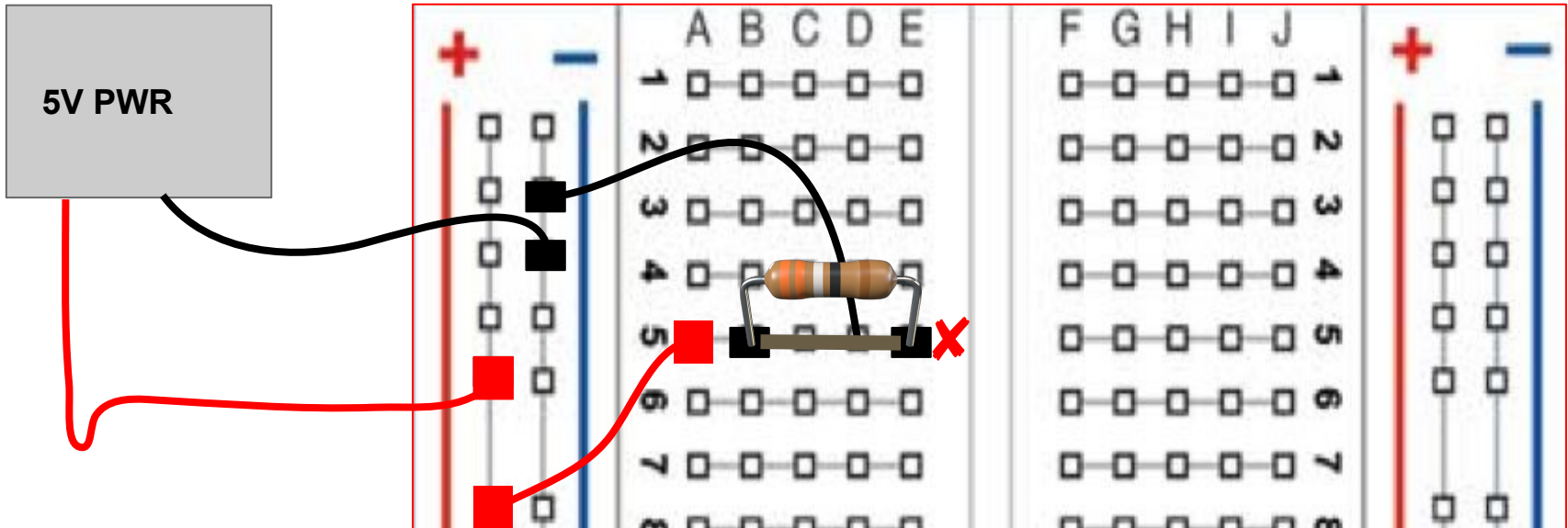
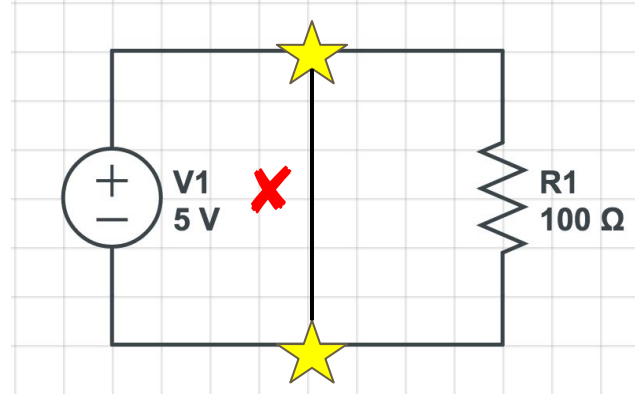

Breadboarding Color Convention

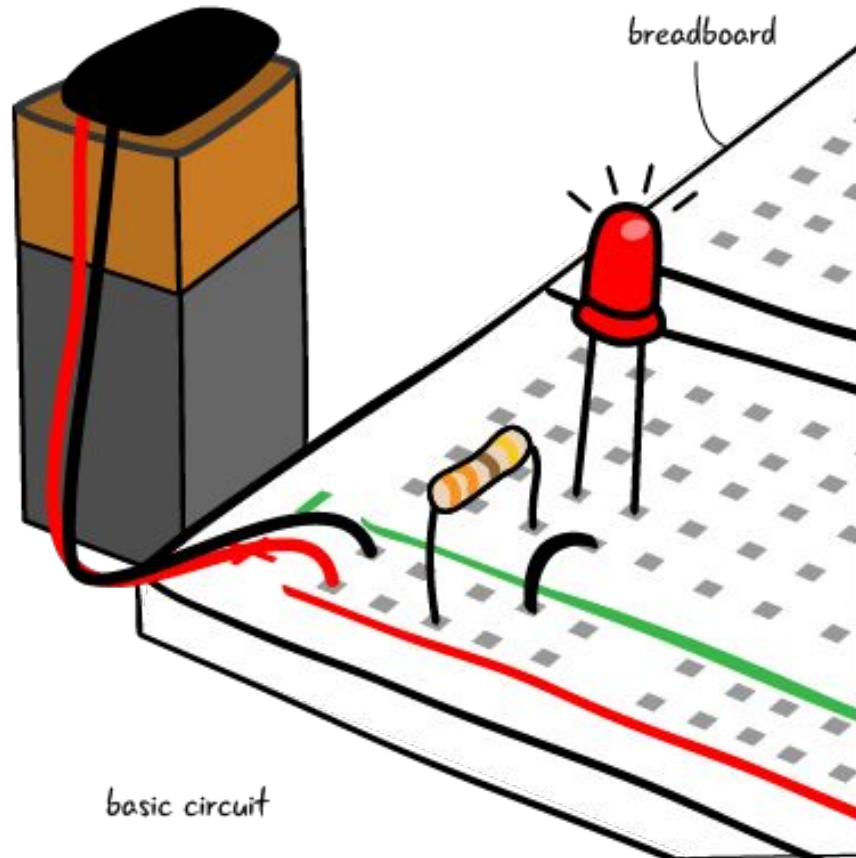

Light-detecting Circuit

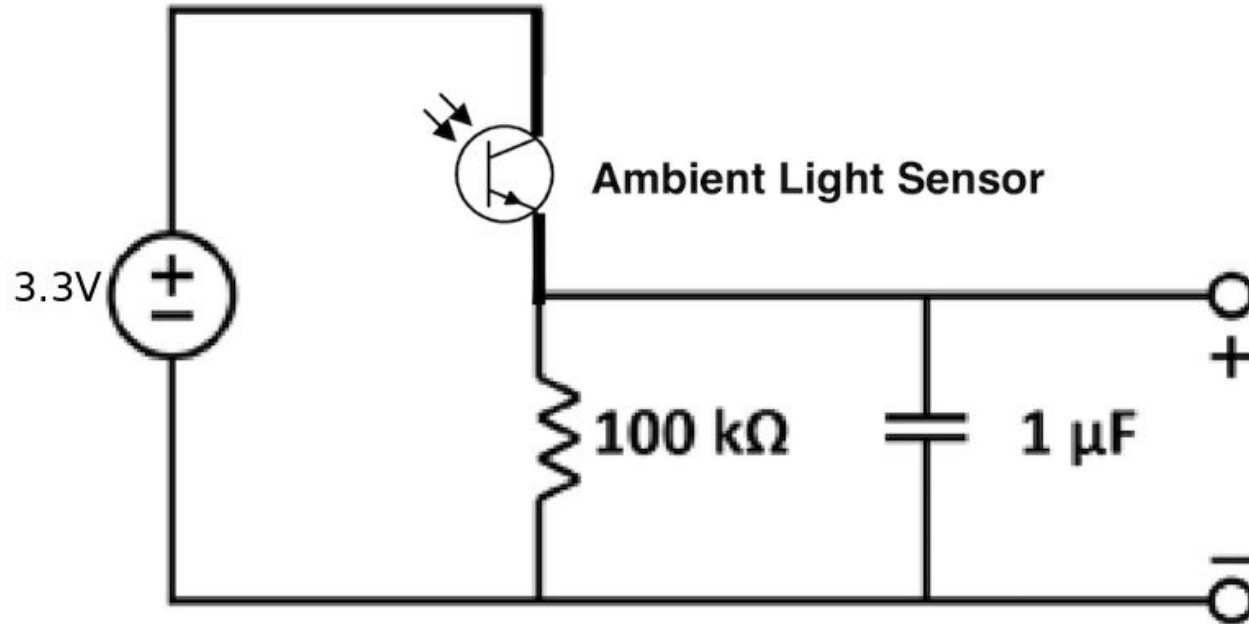

Why the Capacitor?

- The capacitor acts like a bucket of charge – if the input instantaneously increases or decreases, it'll adjust the output flow to compensate
- This results in reducing noise and curve smoothing!

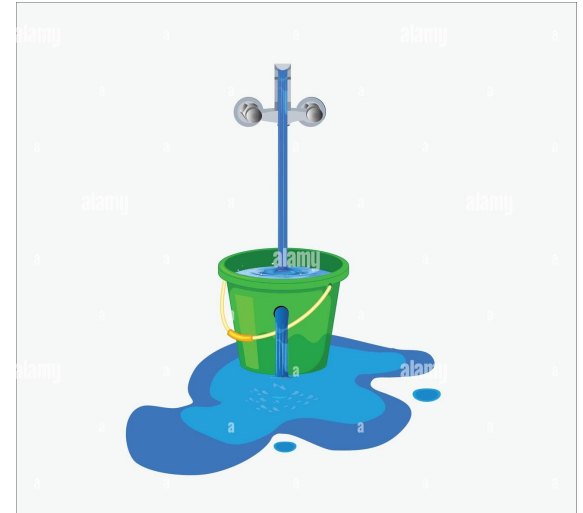
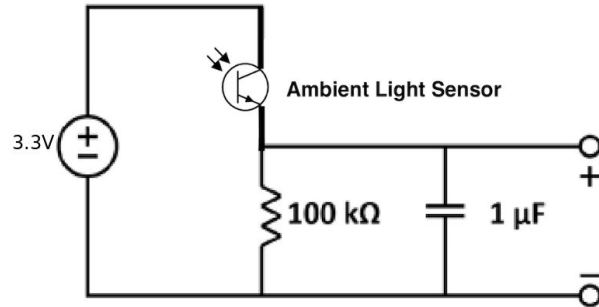
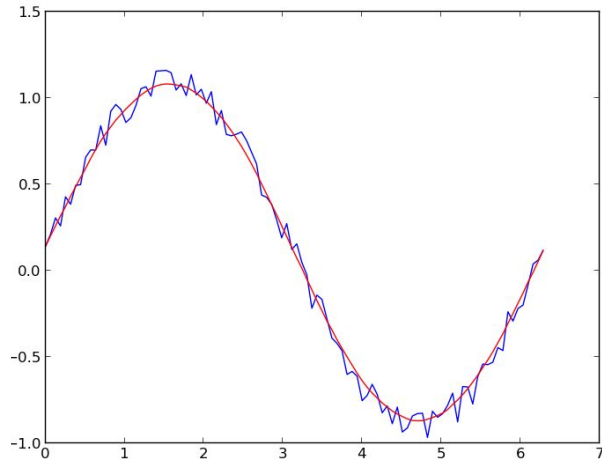

Running Jupyter

- Download the ZIP file from the course website
- Extract the files
- Click on the launch file (Launch.bat) to bring up Jupyter on a local server
- You should see the lab files on a browser window that opens up automatically
- Click on the .ipynb file to start working on the lab!

Lab Rules

- **IMPORTANT:** No food or drink in the lab!
- Be careful with lab equipment. If you are unsure about something, let us know.
- Do not turn off/shut down the computers when you are done. You may switch off the monitors.

FAQ

- Complete the lab in **PAIRS**, do ONE setup and notebook per group (You can also work alone, if that is what you prefer!)
- Speak to the staff if you do not have a partner and would like one
- **DON'T LEAVE/PACK UP YOUR CIRCUIT WITHOUT BEING CHECKED OFF FIRST!!!**
- Checkoff:
 - Fill out the checkoff form (both partners must fill out individual forms. You can use the same signed in email)
 - Wait for a staff member (TA/ASE) to complete the check-off

FAQ

- Make sure current limit of power supply is set to 0.1A
- Turn PSU **output off** while building your circuit
- Keep voltage source leads from LaunchPad to breadboard disconnected while building your circuit
 - Socket ends can stay connected to the LaunchPad
- Probes are on the back wall
- **Make sure you are using the correct resistors (Brown Black Yellow Gold for light sensor)**
- **Make sure your ambient light sensor is in the right direction**
- Before leaving, please return the wires, clean up your stations, and sign out of the computers
- If images in the notebook don't show up, save your work and reopen the notebook/reload the page (F5)