

# EECS 16A    Designing Information Devices and Systems I

## Spring 2023    Pre-Lab Reading 2

### 1 Logistics/Announcements

- (a) Lab 2 (last week) was Imaging 1. Checkoff for this lab was **graded**. If you were unable to get checked off during your assigned section, please make use of the Imaging module buffer lab (week of 02/20) to get credit for this lab. As a reminder, you may get checked off for only one missed lab per buffer period by attending a buffer lab. You must sign up for a buffer lab before attending. Further details regarding buffer labs will be shared on Ed. As an alternative to buffer labs, you may also ask your Lab TA if you can be checked off at the start of next week's section (Imaging 2). If you are unsure about the best course of action for receiving lab credit, please speak with your Lab TA!
- (b) You should have received a lab kit if you attended Imaging 1. If you did not receive one or did not attend Imaging 1, please speak with your Lab TA during lab next week. Make sure you always bring your lab kits to your section!
- (c) Unlike Python Bootcamp, we will not be releasing solutions for any of the labs this semester.

### 2 Imaging 1 Review

Last week, you built your very first circuit! Here's a reminder of what the circuit and the equivalent bread-board diagrams looked like:

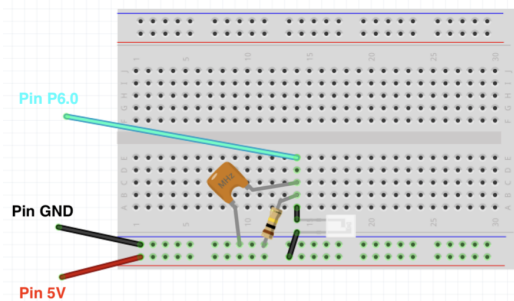
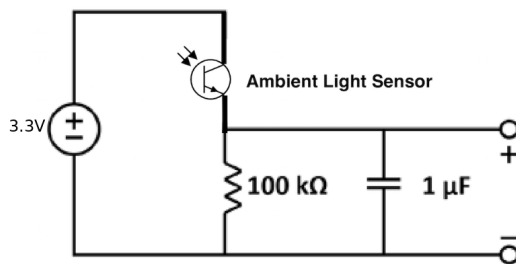

#### What did this circuit do?

This circuit measured light intensity. We saw how the ambient light sensor reacted to brightness/darkness in terms of its voltage and resistance. When the ambient brightness increases, the voltage measured across the resistor/capacitor also increases. The resistance of the light sensor is thus lower when there is more brightness (NOTE: this is not a linear relationship. The true nature of this relationship is out of scope of this class).

### 3 Imaging 2 Overview

Imaging 1 was all about finding a link between a physical quantity (light intensity) and voltage. In Imaging 2, we will look at ways to actually measure this physical quantity in a way that helps us capture image. We

will also look at what measurements are 'good' measurements.

Every image that you see is made up of several pixels. Each pixel has a certain value (usually between 0 and 255 or 0 and 1). We can thus represent an image as a **matrix**, where each value in the matrix corresponds to a pixel in the image. Using this image-matrix (vector) representations, we can now apply familiar linear algebra concepts to scan and reconstruct the images - just like a simple camera would.

How do we "scan" an image? We use something known as a mask matrix, which is simply a matrix that is superimposed on our image matrix such that we can selectively pick which pixels we want to scan at a given time. We will cover more about scanning during the lab so you don't need to worry about it right now. Here's a helpful visual on what a simple mask matrix looks like:

## Pixel-by-Pixel Scan of an Image

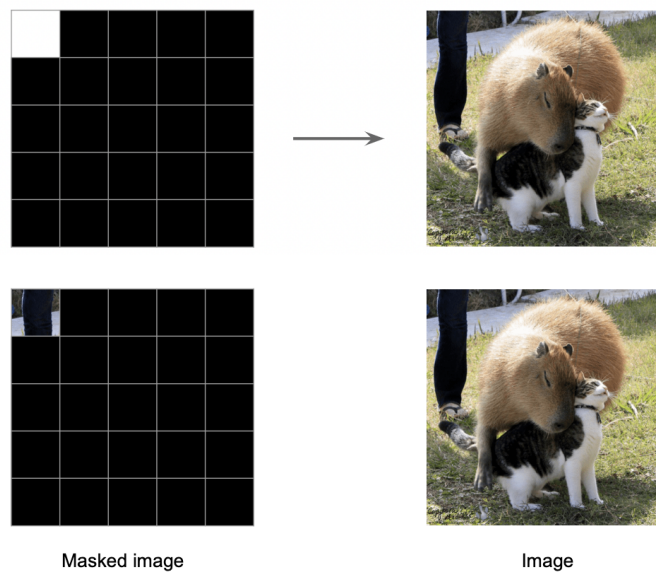

Let's now go over some crucial linear algebra concepts that will we use during lab:

- Linear Dependence:** A set of vectors  $\{\vec{v}_1, \dots, \vec{v}_n\}$  is linearly dependent if there exist scalars  $\alpha_1, \dots, \alpha_n$  such that  $\alpha_1 \vec{v}_1 + \dots + \alpha_n \vec{v}_n = \vec{0}$  and not all  $\alpha_i$ 's are equal to zero. Please refer to Note 3 for a more in-depth review of Linear Dependence.
- Invertibility:** A square matrix  $A$  is said to be invertible if there exists a matrix  $B$  such that

$$AB = BA = I$$

where  $I$  is the identity matrix. In this case, we call the matrix  $B$  the inverse of the matrix  $A$ , which we denote as  $A^{-1}$ . Please refer to Note 6 for a more in-depth review of Matrix Inverses.

How does this relate to our system? In lab we will see that we can setup our imaging system using the following equation:

$$\vec{s} = H\vec{i}$$

where  $\vec{s}$  is the sensor reading (the "scan" that we mentioned earlier),  $H$  is our "mask matrix" and  $\vec{i}$  is the image we want to reconstruct (the unknown). Using the two linear algebra concepts we just covered, you should be able to figure out how and under what conditions we can reconstruct the image vector  $\vec{i}$ . If you are not sure how, stay tuned for the Imaging 2 Lab next week!

---

**Contributors:**

- Shreyash Iyengar
- Ayush Pancholy