

## 15.1 Introduction: Superposition and Equivalence

Circuit analysis can be cumbersome to do by hand, and it can be difficult to understand the high-level behavior of complicated circuits given a schematic. We need tools we can use to both lessen the burden of analysis, and help us think about circuits and understand how they behave. Ultimately, our goal is to **design** interesting circuits, and in this note we will build up additional tools to help us.

## 15.2 Superposition

In this section, we are going to look at circuits with multiple voltage or current sources. In particular, we would like to introduce a very useful idea in working with circuits of this type – superposition.

Let's think back to our seven-step circuit analysis procedure. To solve for the currents and node potentials in a circuit, we set up a matrix problem of the form  $A\vec{x} = \vec{b}$  where  $\vec{x}$  contained the unknown currents and node potentials,  $\vec{b}$  contained the independent current and voltage sources, and  $A$  described the relationship between them. Since this matrix equation describes a real system, we know that there is a unique solution. Therefore,  $A$  is invertible:

$$\vec{x} = A^{-1}\vec{b}$$

This means that we can describe any current or node potential (ie. any element of  $\vec{x}$ ) as a linear combination of the independent current and voltage sources (the elements of  $\vec{b}$ ). For example, consider a circuit with  $n$  independent sources voltage sources  $V_{s1} \dots V_{sn}$ , and  $m$  independent current sources  $I_{s1} \dots I_{sm}$ . An arbitrary node potential  $u_i$  (or equivalently, an arbitrary current  $i_i$ ) can be written as

$$u_i = \alpha_1 V_{s1} + \dots + \alpha_n V_{sn} + \beta_1 I_{s1} + \dots + \beta_m I_{sm}$$

where the  $\alpha$ 's and  $\beta$ 's are coefficients from inverting  $A$ . Since this equation is linear, we can calculate each term of this equation separately and then add them together at the end. For example, if we want to calculate the first term,  $\alpha_1 V_{s1}$  we can set all of the other voltage and current sources to zero, then solve for  $u_i$ . Repeating this for every source then adding the results is equivalent to calculating  $u_i$  with all of the sources present. However, splitting up the calculations can help us see simplifications and patterns that might be less obvious with all of the sources present.

This procedure is known as **superposition** and can be summarized as follows:

**For each independent source  $k$  (either voltage source or current source)**

**Set all other *independent* sources to 0**

- **Voltage source: replace with a wire**
- **Current source: replace with an open circuit**

**Compute the circuit voltages and currents due to this source  $k$**   
**Compute  $V_{out}$  by summing the  $V_{out,k}$ s for all  $k$ .**

Now we ask the question: why does it make sense to replace voltage sources with wires? If we look at the I-V plot of a voltage source  $V_S$ , where  $I$  is the current going through the voltage source, then the plot would be a vertical line:

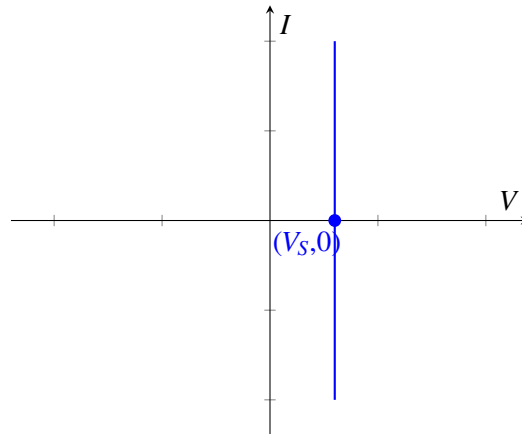

Now if we want to zero out this voltage source, we are setting  $V_S = 0$ . Then the I-V plot is exactly the y-axis.

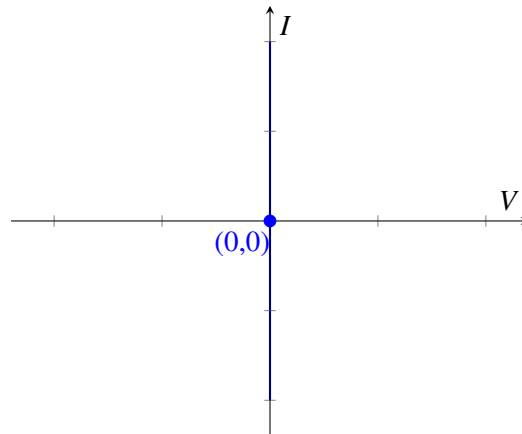

What does this mean? This means that it allows any current to go through, however the voltage drop always remains zero. This is exactly what a wire element (sometimes called a short circuit) does.

Now let's look at why we replace current sources with open circuits. If we plot the I-V graph of a current source  $I_S$ , we get the following:

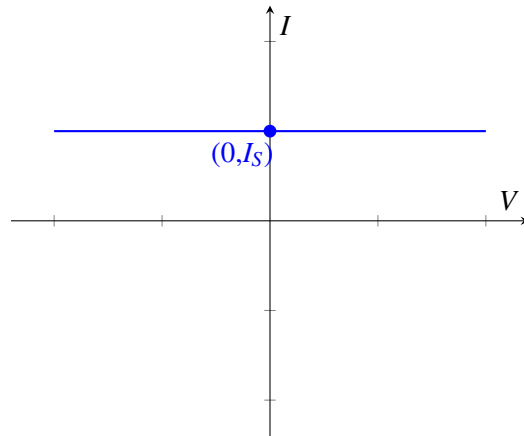

What if we turn off the current source? Then the I-V graph becomes the x-axis, i.e., the line  $I = 0$ .

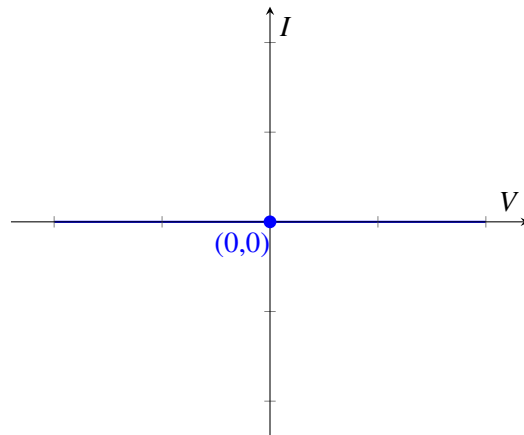

What does this mean? This means no matter what voltage you apply, there will be no current. This is equivalent to an open circuit.

Now let's illustrate this idea on the circuit below, where we would like to figure out  $V_{out}$ .

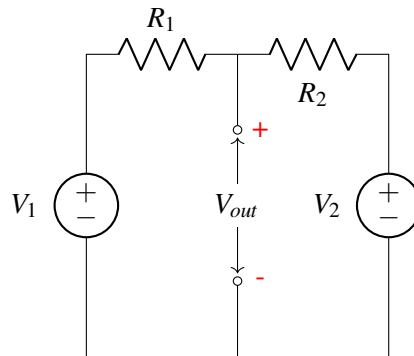

We first compute the output voltage due to  $V_1$  and hence source  $V_2$  will be replaced with a wire:

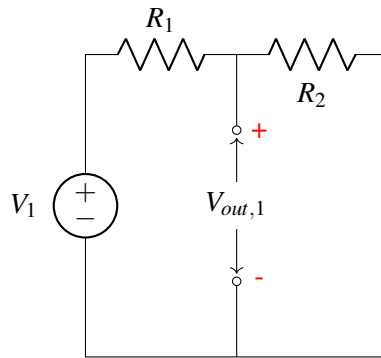

We can recognize this as a voltage divider circuit, and therefore we know that  $V_{out,1} = \frac{R_2}{R_1+R_2}V_1$ . Next we compute the output voltage due to  $V_2$  and hence source  $V_1$  will be replaced with a wire.

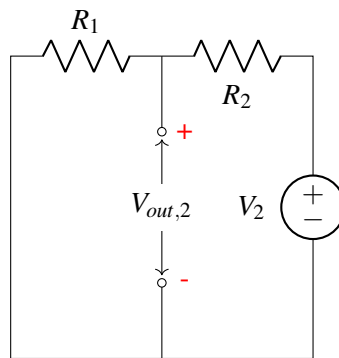

We again recognize that this is just a voltage divider circuit and therefore we can see that  $V_{out,2} = \frac{R_1}{R_1+R_2}V_2$ . Finally, to get the output voltage  $V_{out}$  of the original circuit, we add the contributions from each voltage source  $V_{out} = V_{out,1} + V_{out,2} = \frac{R_2}{R_1+R_2}V_1 + \frac{R_1}{R_1+R_2}V_2$ .

As a side note, we can apply the idea of replacing elements with equivalent elements (e.g. replacing a  $V = 0$  voltage source with a wire) to resistors as well. When do resistors have an equivalent representation? We will try and demonstrate this graphically. Recall that by Ohm's law, the I-V graph across a resistor looks like

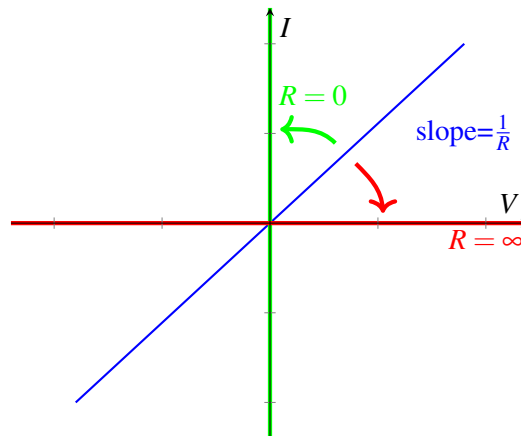

We know that the slope of the line is equal to  $\frac{1}{R}$ . What happens in the limit where  $R$  trends towards infinity? Then the line becomes the x-axis, which corresponds to an open circuit as we've seen earlier. Now what happens in the limit where  $R$  trends towards zero? The line becomes the y-axis, which corresponds to a wire.

To summarize, **zero voltage source and zero resistance are equivalent to wires (i.e. short circuits); zero current source and infinite resistance are equivalent to open circuits.**

## 15.3 Equivalence

One aspect of circuit design that is distinctly different than most software engineering is that when we assemble a large circuit out of a component blocks, each of the blocks can potentially influence the behavior of the others. Does this mean that every addition or change to a circuit means that we need to completely re-analyze the entire system? No, because luckily, the ways they interact are limited in a very specific way that we will discuss. It turns out they actually interact through only 2 parameters, current  $I$  and voltage  $V$ . This leads to a new tool we will develop to help us when describing more complicated/complete circuit models; the concept of equivalence.

Equivalent circuits are used to simplify interactions between circuits. Let's take the simplest case where interactions are only through one pair of nodes. In that case, we just have two possible quantities: the voltage across the nodes and the current flowing through the connections. The relationship between this current and this voltage would then fully define the interactions between the circuits. This is where the idea of equivalence comes in. If we have a circuit that exhibits the same  $I - V$  relationship from the standpoint of a pair of nodes, the other circuit (the one you are interacting with) can't tell the difference. The idea of equivalence is to be able to replace one (or both) of the interacting circuits with a simpler circuit that will give us the same overall behavior.

Before we move on, let's clarify what we mean by "equivalent": **Two circuits are equivalent if they have the same  $I - V$  relationship.** (An example of an  $I - V$  is that of a resistor, i.e.,  $V = IR$  or  $I = \frac{V}{R}$ ). This is *exactly* what we mean by equivalence; be careful not to overextend this definition or apply others. For example, equivalence tells us nothing about the *power* in a circuit and one should be careful not to assume it does.

Now why is this possibly intuitively? Since voltage and current are governed by a linear relationship for all of the circuit elements we've learned about, and a line can be uniquely determined by exactly two points, we can capture the original circuit with a simplified circuit that has exactly two components: a voltage (or current) source and a resistor.

**Definition 15.1 (equivalent circuit):** **If we pick two terminals within a circuit, we say that another circuit is equivalent to the original circuit if it exhibits the same  $I - V$  relationship at those two terminals.**

Note: From the standpoint of any other nodes in the circuit (i.e. any pairs of nodes), the circuit may or may not be equivalent. Furthermore, looking at the same circuit but examining a different pair of terminals may not produce equivalent  $I - V$  relationship.

At a high level, what does it take (at a minimum) to construct a line? We can either use two points along the line, or one point and the slope of the line. Remember, the equivalent circuit of a circuit will have an

identical  $IV$  curve, which is a line. In this class, we will construct these equivalent curves using a point and the slope. The two easiest points to collect along a line are the x-intercept (point with 0 current) and the y-intercept (point with 0 voltage).

There are two types of equivalent circuits we will construct: the *Thevenin* and the *Norton*. For the Thevenin equivalent we look at the intersection with the x-axis (zero current); for the Norton, we look at the intersection with the y-axis (zero voltage).

Next we figure out the slope of the line; remember, for an  $I \times V$  curve, the slope is equal to the resistance ( $V = IR$ ).

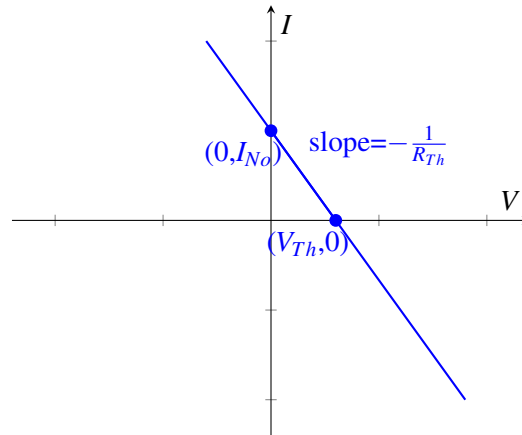

We call the first circuit below, containing a voltage source and a resistor the **Thevenin equivalent circuit**; we call the second circuit, containing a current source and a resistor, the **Norton equivalent circuit**. Once we simplify the original circuit to one of the above, we can easily figure out  $V_{out}$  no matter what resistor it is connected to on the right. In fact, we can convert **any** circuit into any one of these equivalent forms.

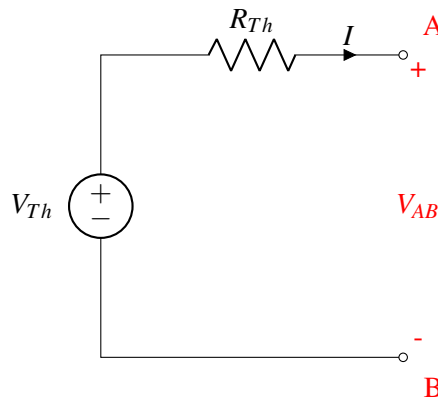

or

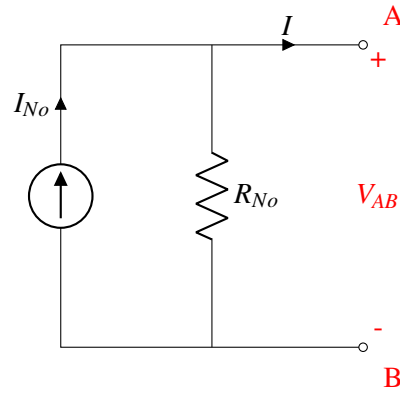

## 15.4 Thevenin Equivalent Circuit

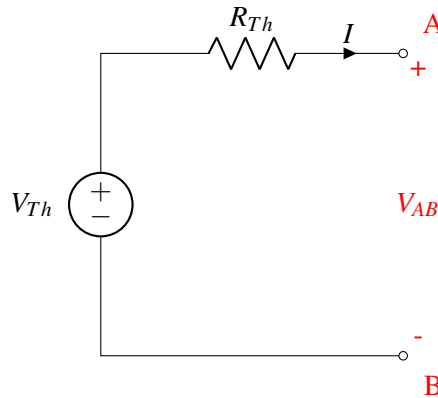

Now how would you figure out  $V_{Th}$  and  $R_{Th}$  for the Thevenin equivalent circuit?

Concretely, the procedure to solve for the Thevenin equivalent is as follows:

**Step 1, find  $V_{Th}$ :** Connect an open circuit across the two output terminals and measure the voltage across them. This measured  $V_{oc}$  equals  $V_{Th}$ .

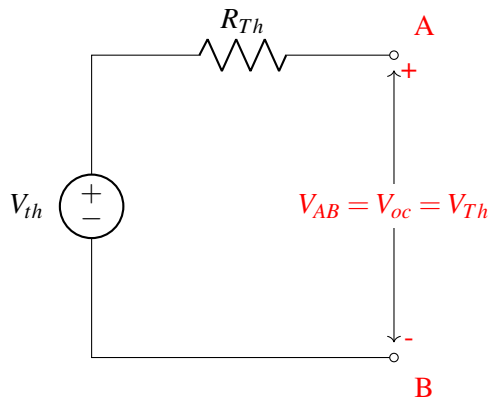

**Step 2, find  $R_{Th}$ :** Zero out any independent sources. Remember, this means voltage sources turn into a wire and current sources turn into an open circuit. Then apply either a test current into the terminal and measure the resultant voltage, or apply a test voltage and measure the resultant current.  $R_{Th} = \frac{V_{test}}{I_{test}}$

## 15.5 Norton Equivalent Circuit

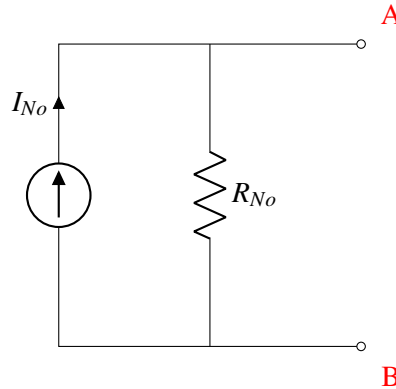

What about solving for the Norton equivalent circuit? First, note that  $R_{No}$  is equal to  $R_{Th}$ , since the slope of the IV curve is the same. Now, instead of looking at the  $V$  axis intercept, we find the intersection with the  $I$ -axis: At the intersection with the  $I$ -axis, the voltage drop between  $A$  and  $B$  is zero, which is equivalent to placing a wire between  $A$  and  $B$  (i.e. shorting  $A$  and  $B$ ). We denote the current through the wire be  $I_{SC}$ .

To put it in terms of our standard procedure:

**Step 1, find  $I_{No}$ :** Connect a short circuit across the two output terminals and measure the current through it. This measured  $I_{SC}$  equals  $I_{No}$ .

**Step 2, find  $R_{No}$ :** Zero out any independent sources. Remember, this means voltage sources turn into a short circuit and current sources turn into an open circuit. Then apply either a test current into the terminal and measure the resultant voltage, or apply a test voltage and measure the resultant current.  $R_{Th} = \frac{V_{test}}{I_{test}}$

Note that the second step doesn't change because  $R_{No}$  is equal to  $R_{Th}$ !

## 15.6 Equivalence Examples

Here will we find the Thevenin equivalents for a set of simple circuits.

### 15.6.1 Series Resistors

Consider the schematic:



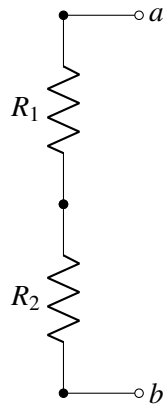

Let's follow the procedure given above.

**Step 1:** Note that there is already an open circuit connected between terminals  $a$  and  $b$ . In this case there is no voltage or current source in the circuit. Therefore, the voltage at every node is the same, and therefore,  $V_{ab,OC} = 0$ . Remember,  $V_{ab,OC} = V_{Th}$ , so  $V_{Th} = 0$ .

**Step 2:** There is no source to zero out in this case. Since it will turn out to be the easier choice, we will apply a test current and measure the resulting voltage, as shown:

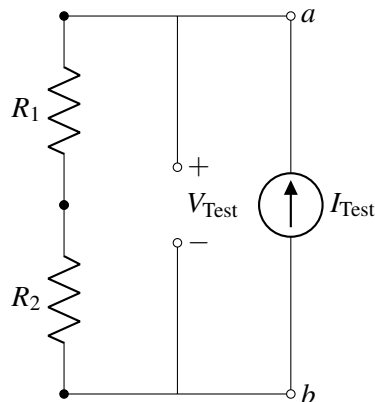

There is only one loop, and therefore all the currents in this circuit are the same.

$$V_{R1} = I_{\text{Test}}R1 \quad (1)$$

$$V_{R2} = I_{\text{Test}}R2 \quad (2)$$

$$V_{\text{Test}} = V_{R1} + V_{R2} = I_{\text{Test}}R1 + I_{\text{Test}}R2 \quad (3)$$

$$V_{\text{Test}} = (R1 + R2)I_{\text{Test}} \quad (4)$$

$$R_{Th} = \frac{V_{\text{Test}}}{I_{\text{Test}}} = R1 + R2 \quad (5)$$

We see that equivalent resistance of these two resistors is simply their sum. We call these resistors in **series**. Note that in order to be in series, the resistors have to have the exact same current through them.

## 15.6.2 Parallel Resistors

Another way to arrange a circuit with two resistors and no voltage source is as follows:

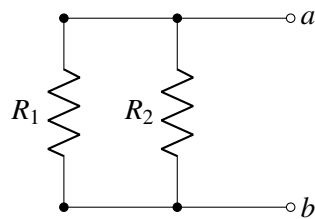

Let's again follow the procedure given above to find our equivalent circuit.

**Step 1:** Note that there is already an open circuit connected between terminals  $a$  and  $b$ . For the same reason as the prior example,  $V_{ab,OC} = 0$  in this case. Therefore,  $V_{Th} = 0$ .

**Step 2:** There is no source to zero out in this case. Since it will turn out to be the easier choice, apply a test voltage and measure the resulting current, as shown:

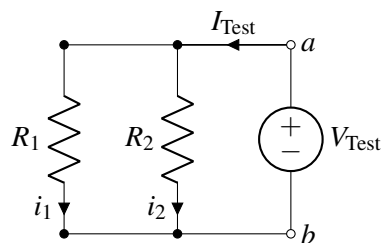

To analyze this circuit, first we notice that the voltage drop over each resistor is equal to  $V_{Test}$ . This is because the voltage drop between node  $a$  and  $b$  is  $V_{Test}$ , and each resistor is connected to node  $a$  on one side and node  $b$  on the other.

First we use the I-V relationship of  $R_1$ .

$$V_{Test} = i_1 R_1 \quad (6)$$

$$i_1 = \frac{V_{Test}}{R_1} \quad (7)$$

Then we use the I-V relationship of  $R_2$ .

$$V_{Test} = i_2 R_2 \quad (8)$$

$$i_2 = \frac{V_{Test}}{R_2} \quad (9)$$

Finally, they are combined to calculate the equivalent resistance.

$$I_{Test} = i_1 + i_2 = \frac{V_{Test}}{R_1} + \frac{V_{Test}}{R_2} \quad (10)$$

$$\frac{I_{Test}}{V_{Test}} = \frac{1}{R_{Th}} = \frac{1}{R_1} + \frac{1}{R_2} \quad (11)$$

Rearranging this expression gives our final resistance:

$$R_{Th} = \frac{R_1 R_2}{R_1 + R_2} \quad (12)$$

We call these resistors in **parallel**. Note that in order to be in parallel, the voltage across them has to be the same.

This mathematical relationship comes up often enough that it actually has a name: the “parallel operator“, denoted  $\parallel$ . When we say  $x \parallel y$ , it means  $\frac{xy}{x+y}$ . Note that this is a mathematical operator and does not say anything about the actual configuration. In the case of resistors the parallel operator is used for parallel resistors, but for other components (like capacitors) this is *not* the case.

**From these analyses, we now have a simple rule to tell if elements are in series or parallel. Series elements will have the exact same current through them due to KCL. Parallel elements will have the exact same voltage across them due to KVL.**

### 15.6.3 Voltage Divider

Now let’s apply our analysis above to a voltage divider circuit shown below (which is very similar to the touchscreen). To figure out  $V_{th}$ , we solve for  $V_{oc}$  in the following circuit

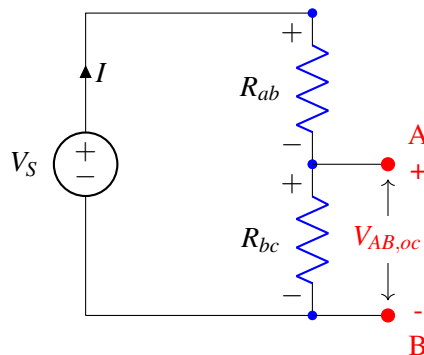

Note that the same current flows through the two resistors. In addition, the voltage drop over the two resistors sums to  $V_s$ , so we can write  $V_{Rab} = V_s - V_{AB,oc}$ . Therefore, using Ohm’s Law:

$$\begin{aligned} I_{Rab} &= I_{Rbc} \\ \frac{V_{Rab}}{R_{ab}} &= \frac{V_{AB,oc}}{R_{bc}} \\ \frac{V_s - V_{AB,oc}}{R_{ab}} &= \frac{V_{AB,oc}}{R_{bc}} \\ \frac{V_s}{R_{ab}} - \frac{V_{AB,oc}}{R_{ab}} &= \frac{V_{AB,oc}}{R_{bc}} \\ V_{AB,oc} &= \frac{R_{bc}}{R_{ab} + R_{bc}} V_s \end{aligned}$$

To figure out  $R_{th}$ , we zero out the independent source and apply a test voltage, measuring the resultant current.

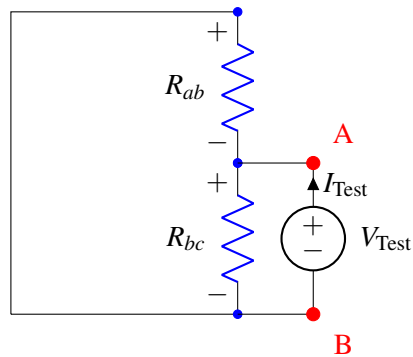

We can see that this is the same as the parallel resistor case we examined above: therefore,  $R_{Th} = \frac{V_{Test}}{I_{Test}} = R_{ab} \parallel R_{bc}$ .

This gives us a resulting Thevenin equivalent circuit of:

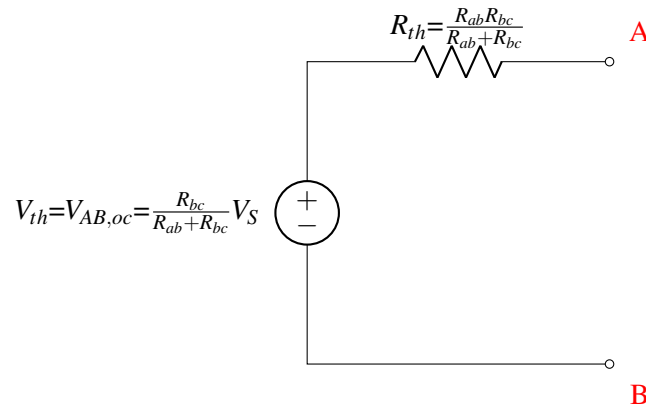

What if we instead chose the upper two nodes (instead of the lower two nodes) as the two terminals (nodes A and B)? We can follow the same procedure to find an equivalent Thevenin circuit from the standpoint of these new nodes,

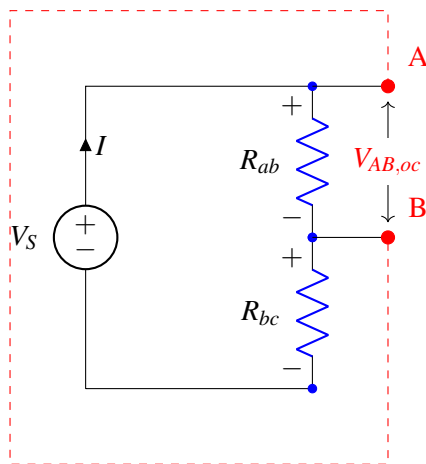

After following the same procedure we get the following equivalent circuit:

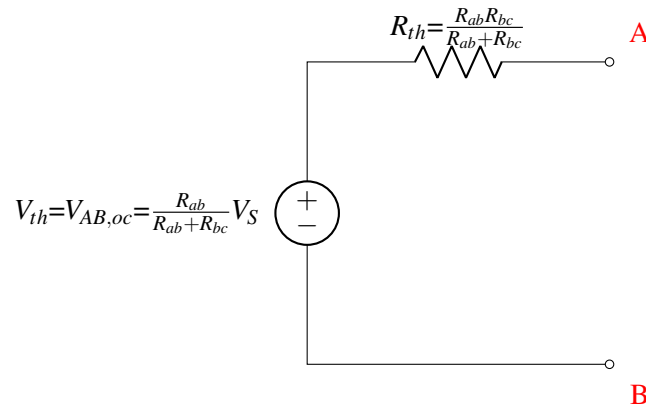

This is not the same result! In this case, the Thevenin voltages in the two circuits are different. This example shows how different pairs of nodes in the same circuit result in different equivalent circuits. In general, there is no guarantee that circuits will behave in the same way from the standpoint of different pairs of nodes.

## 15.7 Summary for Finding Equivalent Resistance

In general, there are three ways of finding the Thevenin/Norton equivalent resistance of a circuit. However, some of them only work in certain situations, so need to be used with caution.

1. Zero out all independent sources and apply a  $V_{test}$  or  $I_{test}$  to calculate the resulting  $I_{test}$  or  $V_{test}$  respectively.  $R_{eq} = \frac{V_{test}}{I_{test}}$ .

This is the method that we described in detail in the examples above, because **this method works for any circuit**. When in doubt, this method is the most reliable.

2. Zero out all independent sources and reduce the entire remaining circuit into a single resistor using the series and parallel resistor formulas that were derived in Sections 15.6.1 and 15.6.2.

**This method does not work if there are dependent sources.** Dependent sources will be discussed later in the course. Remember that only independent sources are zeroed out, and Ohm's Law does not apply (i.e., no resistance) for dependent sources.

In addition, some resistor configurations cannot be fully reduced into a single equivalent resistance utilizing only parallel and series resistance formulas.

3. Calculate  $V_{th}$  and  $I_{no}$ ,  $R_{eq} = \frac{V_{th}}{I_{no}}$ . This is an efficient method of finding  $R_{eq}$  if both the Thevenin and Norton equivalent circuits are being derived. Why does this work? Since the IV relationship is linear, we can calculate the slope (which is the reciprocal of resistance) from any two points.  $V_{th}$  and  $I_{no}$  are the points where the IV curve crosses the  $V$  and  $I$  axes, respectively (see the left-hand figure below).

However, this method does not work if  $V_{th}$  and  $I_{no}$  do not provide two unique points on the IV curve (see the right-hand figure below). Specifically, **this method only works if there is at least one independent source in the circuit**. When there are no independent sources,  $V_{th} = I_{no} = 0$  which does not provide enough information to calculate  $R_{eq}$ .

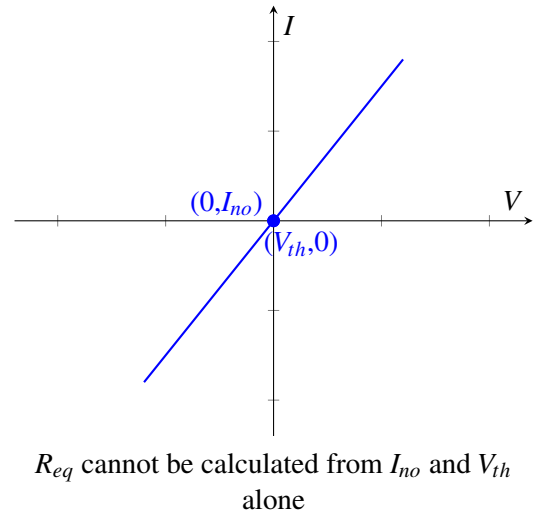
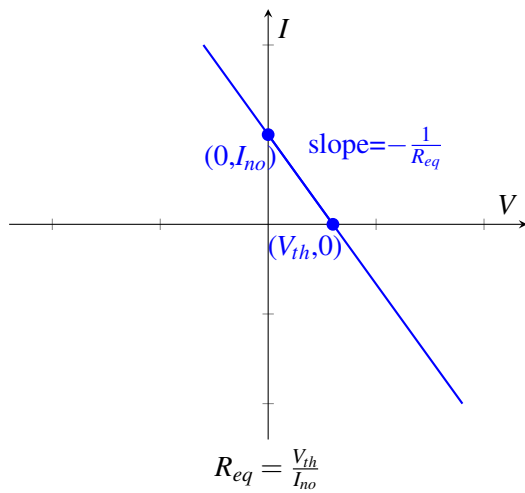

## 15.8 Practice Problems

These practice problems are also available in an interactive form on the course website.

1. True or False: For the following circuit,  $V_{out} < V_{in}$  for any 2 positive resistors  $R_1$  and  $R_2$ .

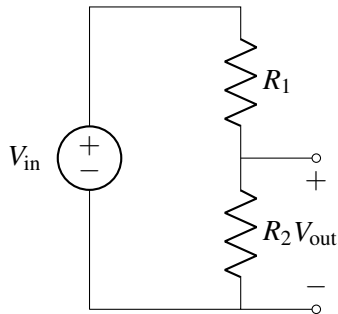

2. Find the equivalent resistance of the following network between  $a$  and  $b$ .

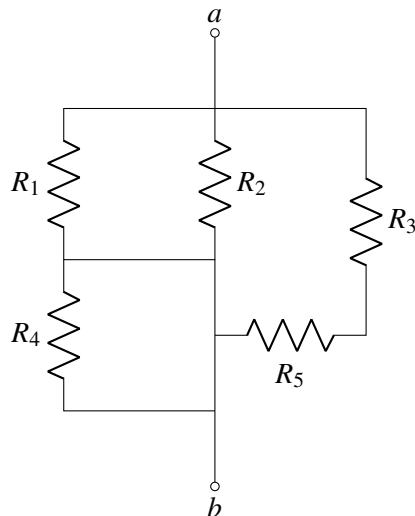

- (a)  $(R_1 + R_4) \parallel R_2 \parallel (R_3 + R_5)$
- (b)  $(R_1 \parallel R_2 + R_4) \parallel (R_3 + R_5)$
- (c)  $R_1 \parallel R_2 \parallel (R_3 + R_5)$
- (d)  $R_1 \parallel R_2 \parallel R_3 + R_4 \parallel R_5$

3. True or False: The power generated by the Thévenin equivalent circuit equals the total power generated in the original circuit.
4. Consider the following circuit:

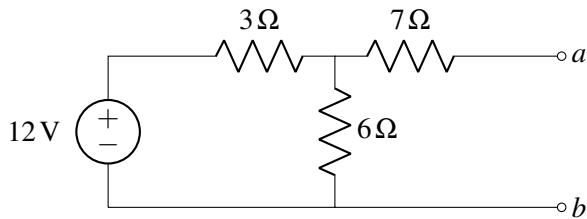

Find  $R_{th}$  and  $V_{th}$  between  $a$  and  $b$ .

5. Consider the following circuit:

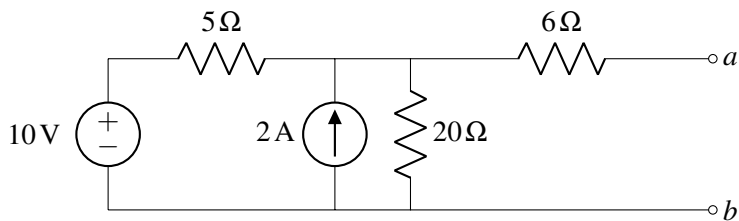

Find  $R_{th}$  and  $V_{th}$  between  $a$  and  $b$ .

6. True or False: Resistors in parallel have an equivalent resistance that is smaller than any of the individual resistances (positive resistance only).
7. What is the voltage between the nodes  $a$  and  $b$ ?

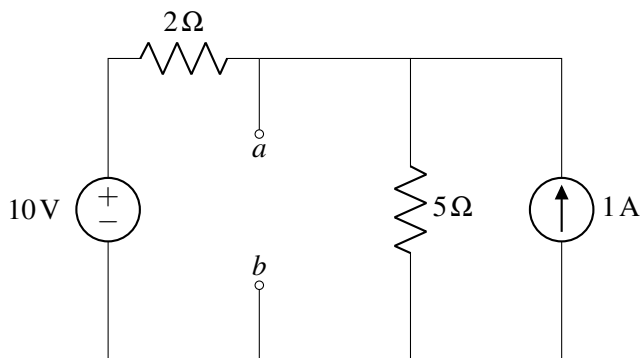

8. For the same circuit above, what is the equivalent Thévenin resistance between the nodes  $a$  and  $b$ ?