

EECS 16A  
Spring 2022

Designing Information Devices and Systems I

Final (170 minutes)

PRINT your student ID: \_\_\_\_\_

PRINT AND SIGN your name: \_\_\_\_\_,  
(last name) (first name) (signature)

PRINT the time of your discussion section and your GSI(s) name: \_\_\_\_\_

PRINT the student IDs of the person sitting on your right: \_\_\_\_\_ and left: \_\_\_\_\_

**1. HONOR CODE**

Please read the following statements of the honor code, and sign your name (you don't need to copy it).

*I will respect my classmates and the integrity of this exam by following this honor code. I affirm:*

- *I have read the instructions for this exam. I understand them and will follow them.*
- *All of the work submitted here is my original work.*
- *I did not reference any sources other than my unlimited printed resources.*
- *I did not collaborate with any other human being on this exam.*



**2. Tell us about something you are looking forward to this summer. (1 point) All answers will be awarded full credit.**

PRINT your student ID: \_\_\_\_\_

### 3. Meow Madness (11 points)

Over quarantine, you adopted a new cat, and as a locked-down signals enthusiast, you spent lots of time noticing patterns in your cat's meows. For instance, the sound your cat makes when it is hungry can be represented as  $\vec{h}[n]$  and the sound when your cat wants to play can be represented as  $\vec{p}[n]$ .

- (a) (4 points) There comes a time when you have to leave your cat with a pet sitter. One day, the pet sitter calls you frantically, not knowing what your cat wants. You receive an audio signal,  $\vec{x}[n]$ , and determine its cross-correlation with  $\vec{h}[n]$  and  $\vec{p}[n]$ . The two cross-correlations,  $\text{corr}_{\vec{x}}(\vec{h}[n])$  and  $\text{corr}_{\vec{x}}(\vec{p}[n])$  are plotted below:

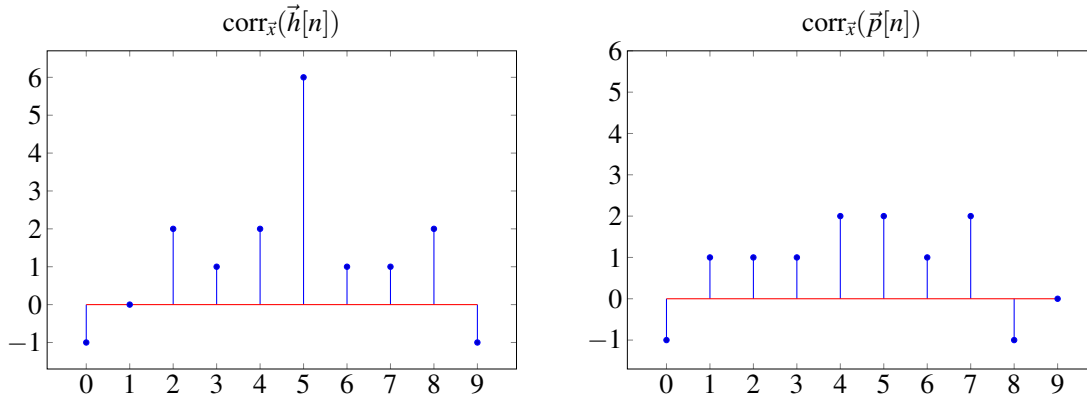

- i. Is your cat more likely to be hungry or want to play? Circle the answer and justify in a sentence or two.

The cat is:    Hungry        Wants to play

- ii. At what time-step of  $\vec{x}[n]$  does the meow begin? Justify.

PRINT your student ID: \_\_\_\_\_

- (b) (3 points) Now, assume that there is a time delay between when your cat meows, and when the meow appears in your audio signal  $\vec{x}[n]$ . This delay is determined by the time it takes for the sound to reach the microphone. You have calculated that the delay is  $t_{delay} = \frac{50}{3}ms$  ( $1ms = 10^{-3}s$ ) and would like to use the delay information to determine where your cat is in the house. You know that your cat has to be in one of the litter boxes either in the bathroom, the bedroom or in the living room. The location of each litter box and of the microphone are shown below.

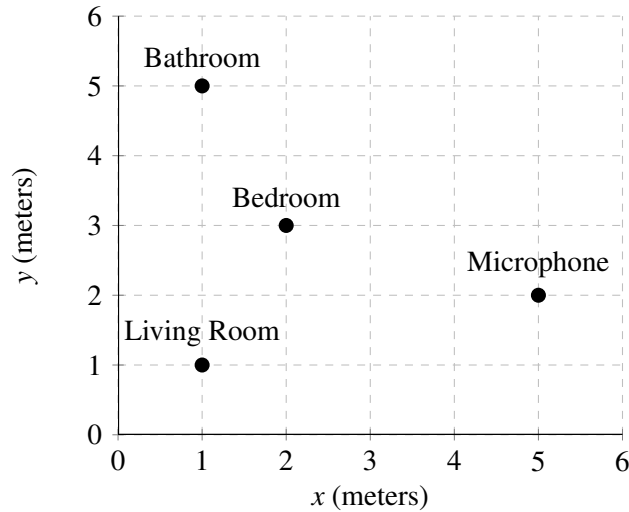
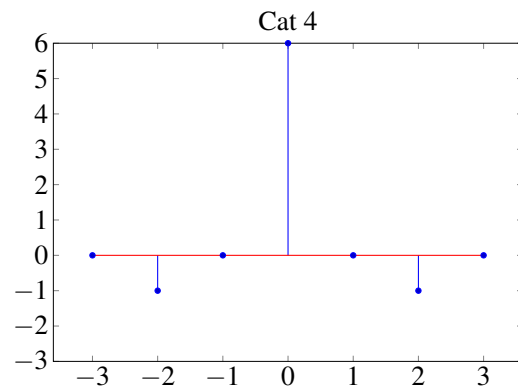
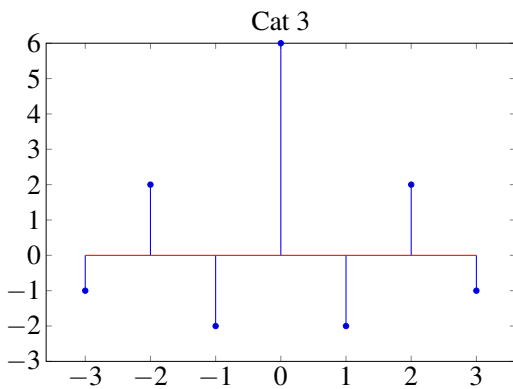
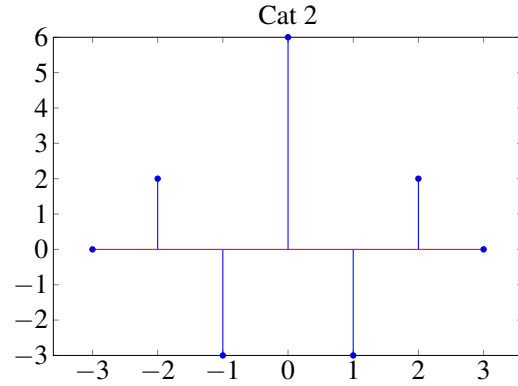
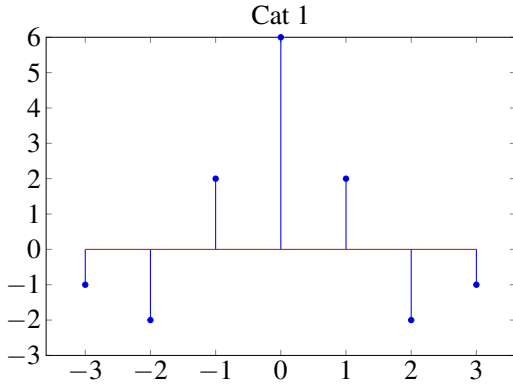

Figure 3.1: Coordinates of litter boxes in each location.

Which location is your cat in? Justify your reasoning. *You can use that the speed of sound is  $v_s = 300m/s$ .*

PRINT your student ID: \_\_\_\_\_

- (c) (4 points) When you go to pick up your cat, you are met with a sea of cats that all look the same! Even your pet sitter is confused by how this came to be. Luckily, it is mealtime, and all of the cats are meowing hungrily. You compute the autocorrelation functions of the meow signals from each of the four cats. The autocorrelation function is defined as  $\text{corr}_{\vec{h}}(\vec{h}[n])$  where  $h[n]$  is the meow signal. Below are the plots of the resulting autocorrelation functions:



Knowing that your cat's "hungry" meow is

$$\vec{h}[n] = [1 \quad -1 \quad 2 \quad 0]$$

which of the cats is yours? Justify your reasoning.

*More space is provided on the next page if needed.*

PRINT your student ID: \_\_\_\_\_



PRINT your student ID: \_\_\_\_\_

#### 4. Eurovision Song Contest (12 points)

The Eurovision Song Contest is a music contest between countries. A participant from each country gives a performance and the remaining countries score this performance. The performance obtaining the highest total score wins. In this example, there are  $n$  countries voting for three performances from Country A, Country B and Country C. You can assume that the performing countries do not vote.

Each of the  $n$  voting countries gives 3 points to the country with the best performance, 2 to the second best and 1 for the last. The points received from each country are summed together to obtain the total score.

- (a) (3 points) Miki and Ana are very enthusiastic about the contest and make predictions of the total score. Their predictions ( $p_{\text{Ana}}$  and  $p_{\text{Miki}}$ ) and the true total scores ( $p_{\text{true}}$ ) are:

$$p_{\text{Ana}} = \begin{bmatrix} 14 \\ 34 \\ 13 \end{bmatrix} \quad p_{\text{Miki}} = \begin{bmatrix} 12 \\ 37 \\ 10 \end{bmatrix} \quad p_{\text{true}} = \begin{bmatrix} 13 \\ 35 \\ \alpha \end{bmatrix}$$

where  $\alpha$  is unknown. If  $\|p_{\text{Ana}} - p_{\text{true}}\|^2 < \|p_{\text{Miki}} - p_{\text{true}}\|^2$ , what are the possible values for  $\alpha$ ?

PRINT your student ID: \_\_\_\_\_

(b) (6 points) The total points can be expressed as the result of a matrix-vector multiplication:

$$\begin{bmatrix} & \\ & A \\ & \end{bmatrix} \begin{bmatrix} 3 \\ 2 \\ 1 \end{bmatrix} = \begin{bmatrix} p_A \\ p_B \\ p_C \end{bmatrix}$$

where  $A$  is an unknown matrix which stores information on scoring and  $\vec{p} = [p_A \ p_B \ p_C]^T$  is the total points received by countries A, B and C.

You are given that the eigenvalues of  $\mathbf{A}$  are  $\lambda_1 = 6$ ,  $\lambda_2 = 0.5$  and  $\lambda_3 = 0$ . The corresponding eigenvectors are:

$$\vec{v}_1 = \begin{bmatrix} 1 \\ 0 \\ 1 \end{bmatrix} \quad \vec{v}_2 = \begin{bmatrix} 1 \\ 1 \\ 0 \end{bmatrix} \quad \vec{v}_3 = \begin{bmatrix} 0 \\ 1 \\ 1 \end{bmatrix}$$

What would be the resulting total points,  $\vec{p}$ , that would be obtained with this matrix  $\mathbf{A}$ ?

PRINT your student ID: \_\_\_\_\_

- (c) (3 points) Somehow your voting system has gotten corrupted. The corrupted total points you obtain is  $\vec{p}_{\text{corrupt}} = [20 \ 15 \ 5]^T$ . You have been told that the uncorrupted (true) points satisfy  $p_A = 2p_B = 2p_C$ . You know that the corruption is small, so the true points must be close to what you received after the corruption. Use projection to find a vector,  $\vec{p}^*$ , that satisfies the constraint and is closest to  $\vec{p}_{\text{corrupt}}$ .





PRINT your student ID: \_\_\_\_\_

### 5. Can I Give You Some Feedback? (4 points)

The following circuit is a linear voltage regulator.

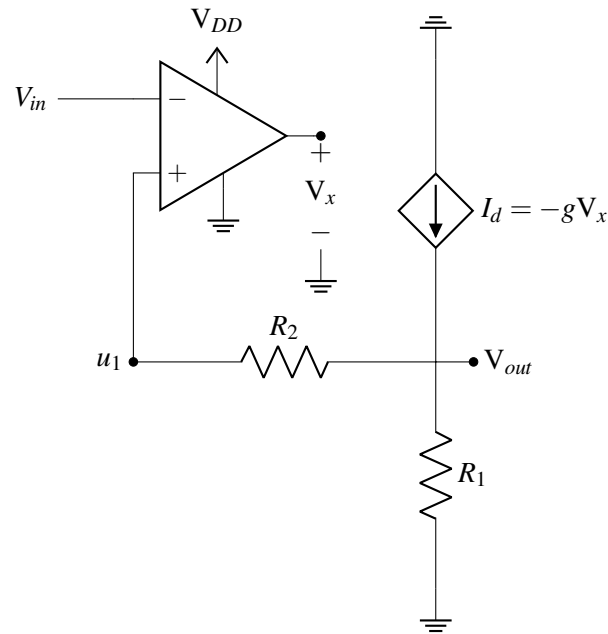

$V_{DD}$  and  $V_{in}$  are both connected to ideal voltage sources.  $g$  is the gain factor of the dependent current source. The opamp has finite gain  $A$ .

Using the method for negative feedback analysis, if  $V_{out}$  **increases**, determine what happens to the following values. Circle one of the two options for each line below. *Note that if a quantity is getting more negative, that means it is decreasing.*

Voltage at  $u_1$  will:    Increase    Decrease

$V_x$  will:    Increase    Decrease

Dependent current  $I_d$  will:    Increase    Decrease

The circuit is in:    Negative Feedback    Positive Feedback

PRINT your student ID: \_\_\_\_\_

### 6. R-I-P Loads (11 points)

One model for representing the behavior of a household appliance under different conditions is with the R-I-P model, which models the device as the parallel combination of a resistor, a current source, and a component that consumes a constant amount of power (shown as a box labeled P):

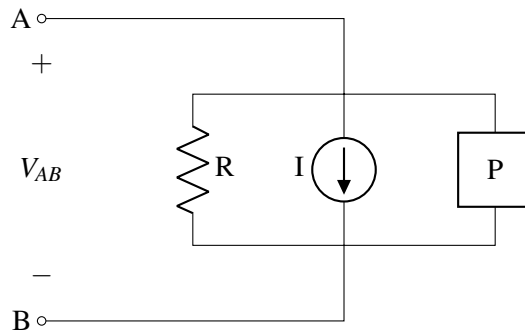

- (a) (3 points) Suppose we apply a test voltage  $V_{AB}$  to this device. How much power will the device use? Express your answer in terms of  $V_{AB}$ ,  $I$ ,  $R$ , and/or  $P$ .

PRINT your student ID: \_\_\_\_\_

- (b) (2 points) Usually the values of  $R$ ,  $I$  and  $P$  are not known ahead of time, so we need to estimate them by measuring the power dissipated by the device at different values of  $V_{AB}$ . What is the minimum number of values of  $V_{AB}$  we could measure at in order to generate a least squares estimate for the values of  $R$ ,  $I$  and  $P$ ?

- (c) (6 points) Now assume that we have a new model where the I-V relationship can be modeled as

$$I = k_0 + \frac{k_1}{V},$$

where  $k_0$  and  $k_1$  are device-specific constants. You want to estimate  $k_0$  and  $k_1$  for a given device, so you apply several test voltages and measure the corresponding current through the device. You get the following measurements:

V	I
$-\frac{1}{3}$ V	-1 A
0.5 V	1 A
1 V	9 A

Given that your ammeter may have some amount of error, find the best estimate of  $k_0$  and  $k_1$  using least squares. Show your work.

*More space is provided on the next page if needed.*

PRINT your student ID: \_\_\_\_\_

A large, empty rectangular box with a thin black border, occupying most of the page. It is intended for the student to write their student ID.

PRINT your student ID: \_\_\_\_\_

### 7. Danville Doozy (9 points)

Aniruddh has been watching a lot of Phineas and Ferb lately, and has decided to use his EECS 16A knowledge to learn more about the denizens of Danville.

- (a) (3 points) Phineas and Ferb have finally built Croquet Y8. In this version, there are lots and lots of balls instead of just one. Let's say the players are Baljeet, Adyson, and Isabella, and the number of balls in each player's possession can be denoted by  $x_B$ ,  $x_A$ , and  $x_I$ , respectively. Suppose we can represent the movement of the balls via the following state transition diagram.

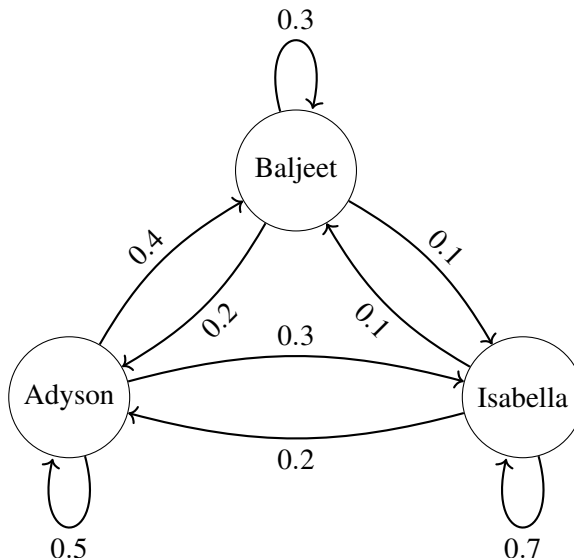

The current number of balls in each player's possession at time-step  $t$  is given by the state vector  $\vec{x}[t]$  defined as:

$$\vec{x}[t] = \begin{bmatrix} x_B[t] \\ x_A[t] \\ x_I[t] \end{bmatrix} = \begin{bmatrix} \text{number of balls in Baljeet's possession at time } t \\ \text{number of balls in Adyson's possession at time } t \\ \text{number of balls in Isabella's possession at time } t \end{bmatrix}$$

Explicitly write out the transition matrix  $\mathbf{T}$  from the provided diagram such that  $\mathbf{T} \vec{x}[t] = \vec{x}[t+1]$ .

PRINT your student ID: \_\_\_\_\_

- (b) (2 points) Suppose instead that the transition matrix,  $\mathbf{T}$  is:

$$\begin{bmatrix} 0.2 & 0.0 & 0.8 \\ 0.2 & 0.6 & 0.4 \\ 0.1 & 0.4 & 0.3 \end{bmatrix}$$

Is this matrix **conservative**? Justify.

- (c) (4 points) Now suppose there is a transition matrix  $\mathbf{B}$  with eigenvalues  $\lambda_1 = 1$ ,  $\lambda_2 = 2$ , and  $\lambda_3 = \frac{1}{2}$ , and

corresponding eigenvectors  $\vec{v}_1 = \begin{bmatrix} 1 \\ 1 \\ 0 \end{bmatrix}$ ,  $\vec{v}_2 = \begin{bmatrix} -1 \\ -2 \\ 1 \end{bmatrix}$ , and  $\vec{v}_3 = \begin{bmatrix} 1 \\ 0 \\ 0 \end{bmatrix}$ .

Given  $\vec{x} = \begin{bmatrix} 3 \\ 2 \\ 0 \end{bmatrix}$ , does  $\lim_{n \rightarrow \infty} \mathbf{B}^n \vec{x}$  converge? If so, what does it converge to?

PRINT your student ID: \_\_\_\_\_

### 8. Plane Repair (9 points)

Congratulations! You've just been hired as the lead of the airplane repair division at Boeing. As your first task, the company wants you to help design their repair queueing system. The setup is as follows:

Each plane has a profile  $\vec{v} \in \mathbb{R}^2$  that describes it, where the the first entry of  $\vec{v}$  represents the the number of thousand miles the plane has flown and the second entry of  $\vec{v}$  represents the priority of the aircraft. For example, the profile

$$\vec{v} = \begin{bmatrix} 650 \\ 2.5 \end{bmatrix}$$

represents a plane that has flown 650,000 miles and has a priority of 2.5.

Like all other airplane companies, Boeing's queueing system takes the profile of all the planes that have come in for repair and orders them by their profile's norm squared ( $\langle \vec{x}, \vec{x} \rangle$ ), from largest to smallest, to determine in which orders the planes need to be fixed. Your job is to help design an inner product  $\langle \vec{x}, \vec{y} \rangle$  to achieve appropriate queueing behavior.

Luckily, you have a friend at Airbus who has worked on the same task years ago. The formula that Airbus uses looks as follows:

$$\langle \vec{x}, \vec{y} \rangle = \vec{x}^T \mathbf{M} \vec{y}, \text{ where } \mathbf{M} = \begin{bmatrix} \frac{1}{100} & \frac{1}{10} \\ \frac{1}{10} & 2 \end{bmatrix}$$

- (a) (3 points) If two planes, Plane 1 with profile  $\vec{v}_1 = \begin{bmatrix} 30 \\ 3 \end{bmatrix}$  and Plane 2 with profile  $\vec{v}_2 = \begin{bmatrix} 20 \\ 10 \end{bmatrix}$  come into Airbus' repair shop, using Airbus' formula, which of the planes would be repaired first? In other words, which plane has the larger norm squared ( $\langle \vec{x}, \vec{x} \rangle$ )?

*More space is provided on the next page if needed.*

PRINT your student ID: \_\_\_\_\_

A large, empty rectangular box with a thin black border, occupying most of the page. It is intended for the student to write their student ID.



PRINT your student ID: \_\_\_\_\_

- (b) (6 points) You decide to take inspiration from Airbus and design your own inner product of the form

$$\langle \vec{x}, \vec{y} \rangle = \vec{x}^T \mathbf{A} \vec{y} \text{ where } \mathbf{A} \text{ takes the form } \mathbf{A} = \begin{bmatrix} a_1 & 0 \\ 0 & a_2 \end{bmatrix}$$

What values must  $a_1$  and  $a_2$  be such that, for  $\vec{x} = \begin{bmatrix} 10 \\ 2 \end{bmatrix}$  and  $\vec{y} = \begin{bmatrix} 20 \\ 1 \end{bmatrix}$ ,  $\langle \vec{x}, \vec{x} \rangle = \langle \vec{y}, \vec{y} \rangle = 5$ ?

PRINT your student ID: \_\_\_\_\_

**9. Equivalent (11 points)**

Suppose you are building a new house and are trying to source the correct lights to use.

- (a) (3 points) The building is powered by a constant voltage source, modeled by the following circuit. You plan for your light (modeled by a load resistor  $R_L$ ) to be connected across terminals  $a$  and  $b$ . If your wiring can handle up to  $5\text{mA}$  (milli =  $10^{-3}$ ) across terminals  $a$  and  $b$ , what is the range of resistance values  $R_L$  that you can connect across those terminals, where  $V_S = 10\text{V}$  and  $R_S = 1\text{k}\Omega$  (kilo =  $10^3$ )?

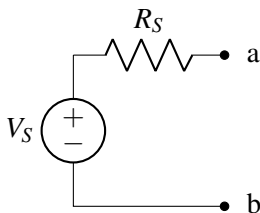

PRINT your student ID: \_\_\_\_\_

- (b) (8 points) Rather than the simplified circuit above, your wiring is actually made up of the following circuit components where  $V_S = 10V$ ,  $R = 1\Omega$

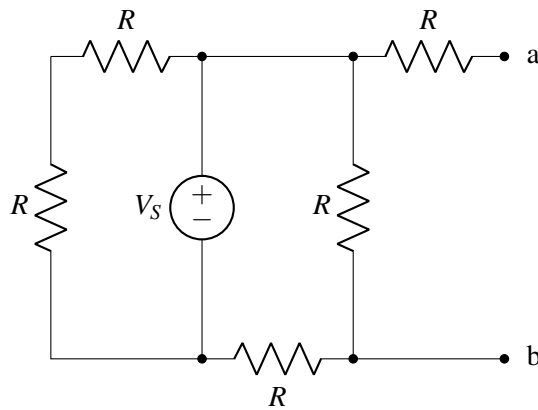

**Figure 1**

Provide values for  $I_{eq}$  and  $R_{eq}$  for the circuit below that will result in the same  $I - V$  characteristics across **nodes a and b** as the circuit in Figure 1.

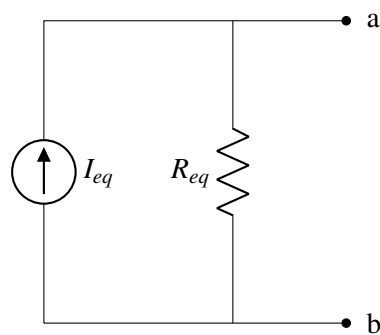

$I_{eq} =$                        $R_{eq} =$

*More space is provided on the next page if needed.*

PRINT your student ID: \_\_\_\_\_



PRINT your student ID: \_\_\_\_\_

### 10. Charge Sharing with Op Amps (10 points)

For the following circuit, assume that all capacitors are initially uncharged, every switch is open, and  $I_s$  and  $V_s$  are constant sources. During phase 1:  $\phi_1$  switches are closed and the  $\phi_2$  switch is open. During phase 2: the  $\phi_2$  switch is closed and  $\phi_1$  switches are open.

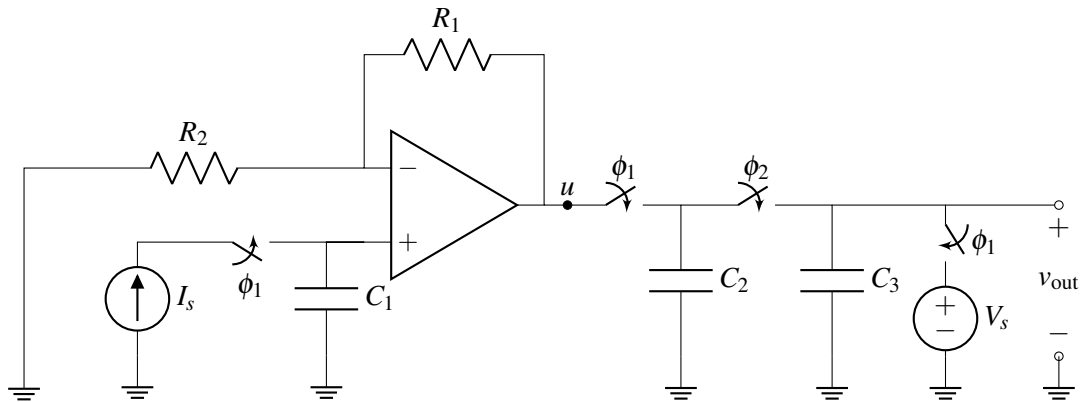

- (a) (6 points) At time  $t = 0$ , phase 1 starts. Compute  $u^{\phi_1}(t)$ , the voltage at node  $u$  during phase 1 in terms of  $t$ ,  $I_s$ ,  $C_1$ ,  $C_2$ ,  $C_3$ ,  $R_1$ ,  $R_2$ , and/or  $V_s$ .

PRINT your student ID: \_\_\_\_\_

- (b) (4 points) After  $\tau$  seconds have elapsed, the switches labeled  $\phi_1$  open and the switch labeled  $\phi_2$  closes. Compute  $v_{out}$  in phase 2 in terms of  $u^{\phi_1}(\tau)$ ,  $I_s$ ,  $C_1$ ,  $C_2$ ,  $C_3$ ,  $R_1$ ,  $R_2$ , and/or  $V_s$ .



PRINT your student ID: \_\_\_\_\_

**11. Amped Up On Op Amps! (11 points)**

(a) (3 points) For the following circuit, find  $V_{out}$  in terms of  $V_{in}$  and/or  $R$ .

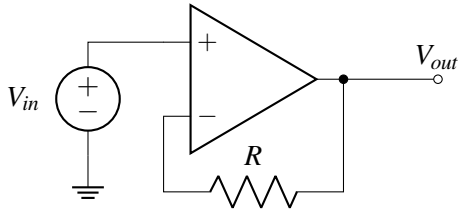

PRINT your student ID: \_\_\_\_\_

- (b) (8 points) For the following circuit in negative feedback, find an expression for node  $V_{out}$  in terms of  $V_{in}$ ,  $V_1$ , and any other necessary labelled circuit components.

*Hint: You may want to start by performing KCL analysis at the  $u_-$  node and solving  $u_-$  in terms of  $V_{out}$  and other variables.*

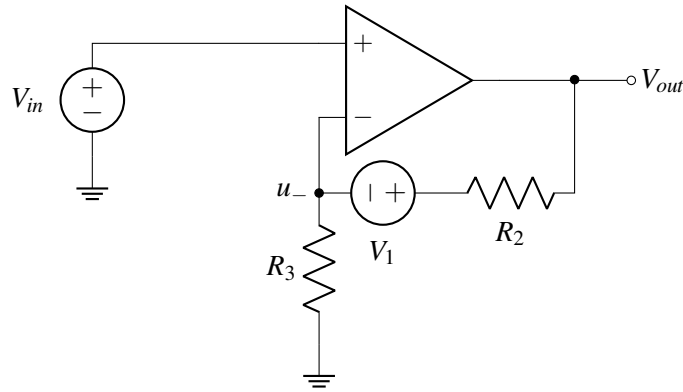



PRINT your student ID: \_\_\_\_\_

**12. Eigenvalues Galore (11 points)**

- (a) (7 points) Prove that if a square matrix  $\mathbf{A}$  is equal to  $\mathbf{A}^2$  ( $\mathbf{A} = \mathbf{A}^2$ ), then all of the eigenvalues of  $\mathbf{A}$  are either 0 or 1.



PRINT your student ID: \_\_\_\_\_

- (b) (4 points) Given matrix  $\mathbf{B} = \begin{bmatrix} 1 & 0 & 0 \\ 0 & \frac{1}{\sqrt{3}} & 0 \\ 0 & 0 & -2 \end{bmatrix}$ , find the eigenvalues of  $4((\mathbf{B}^{-1})^T)^4$ .



PRINT your student ID: \_\_\_\_\_

### 13. An Easier Way To Do Math Homework (10 points)

You're working on your Math 1B homework and you don't know how to calculate an integral. Instead, you decide to put your circuit skills to use to solve this problem!

The integral that you're trying to solve is of the form

$$-\frac{1}{5} \int_0^\tau x(t) dt$$

Your helpful lab TA, Raghav, gives you several circuit elements that you can use.

These elements are:

- A current source  $I_s = x(t)$  amps in parallel with a capacitance of 1F.
- **Two** op-amps (assume that the supply voltages to the op-amps are provided).
- A resistor  $R_{\text{fixed}} = 1\text{k}\Omega$ .
- One additional resistor  $R_{\text{extra}}$  that can have **any value**. Be sure to specify the resistance you use.

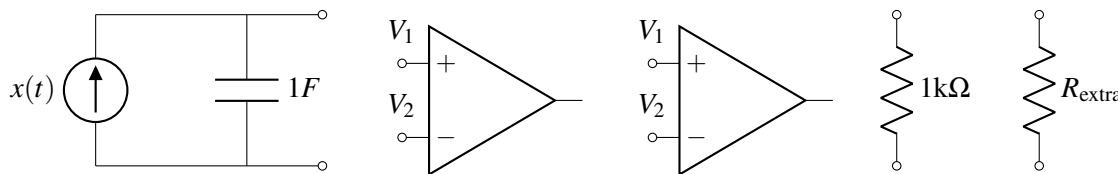

Design a circuit to have the above output using the provided elements. Clearly specify the resistance of  $R_{\text{extra}}$  if used.

*More space is provided on the next page if needed.*

PRINT your student ID: \_\_\_\_\_

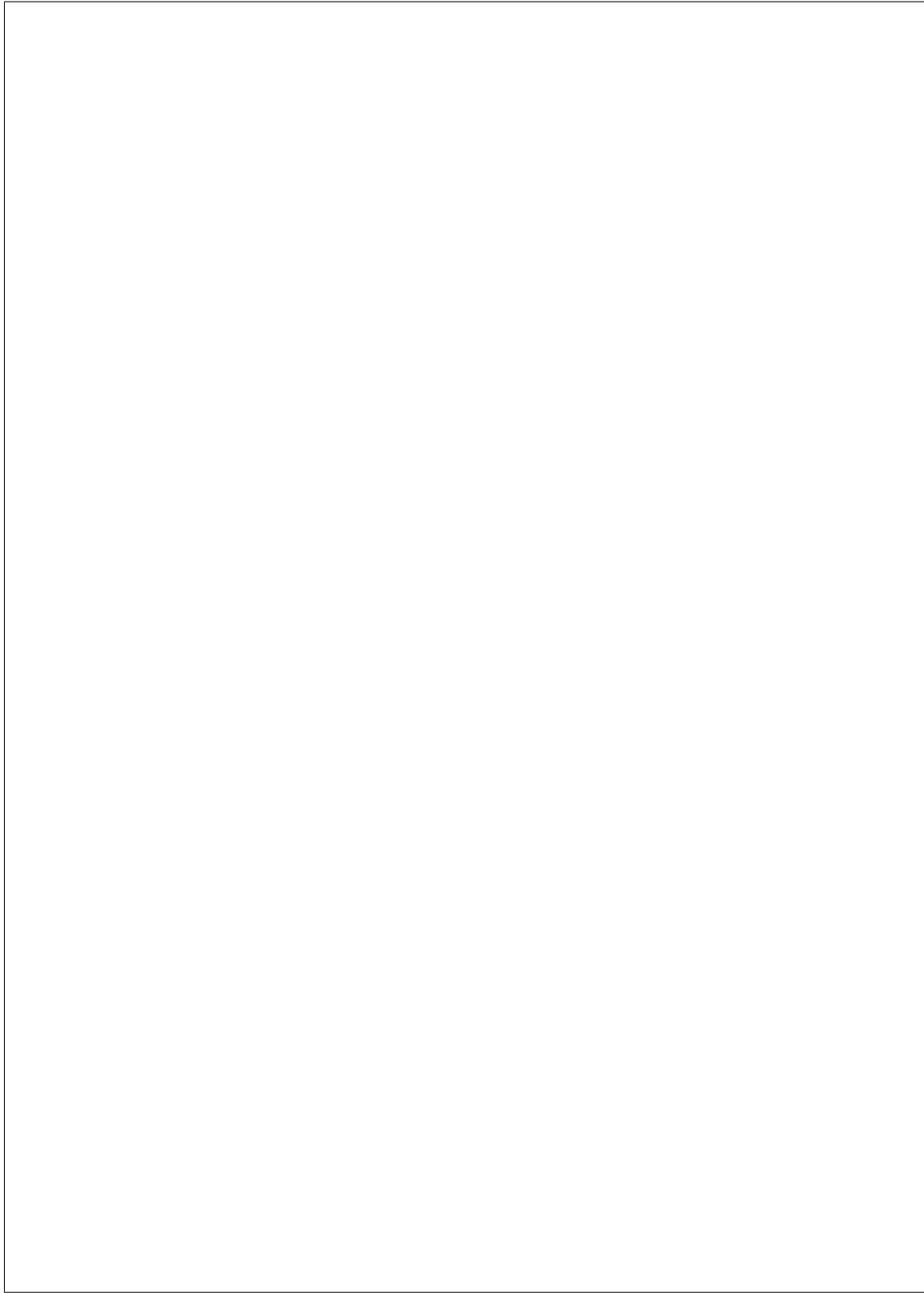

PRINT your student ID: \_\_\_\_\_

Extra page for scratchwork.  
**Work on this page will NOT be graded.**

PRINT your student ID: \_\_\_\_\_

Extra page for scratchwork.  
**Work on this page will NOT be graded.**

PRINT your student ID: \_\_\_\_\_

Extra page for scratchwork.  
**Work on this page will NOT be graded.**