

Lab 1: Intro to SIXT33n

EECS 16B Fall 2022

We'll start on Berkeley Time!

Slides: <https://links.eecs16b.org/lab1-slides>

Administrativa

- Sections should now be locked
 - If you would like to request to permanently change sections, please made a private post on Ed
 - Please attend your enrolled section unless you have signed up for a makeup section
- Make sure you have created an instructional web account to log in to lab computers
- Ensure that your gradescope account email matches you official main Berkeley email (you may not receive lab grades otherwise)

Lab Overview and Goals

Lab Overview

- Lab kit distribution
- Lab equipment training
- Build inverting amplifier on your physical breadboard

Lab Goals

- Gain experience in debugging circuitry
- Practice breadboarding on a physical breadboard
- Learn how to use lab equipment!!!

Breadboarding 101

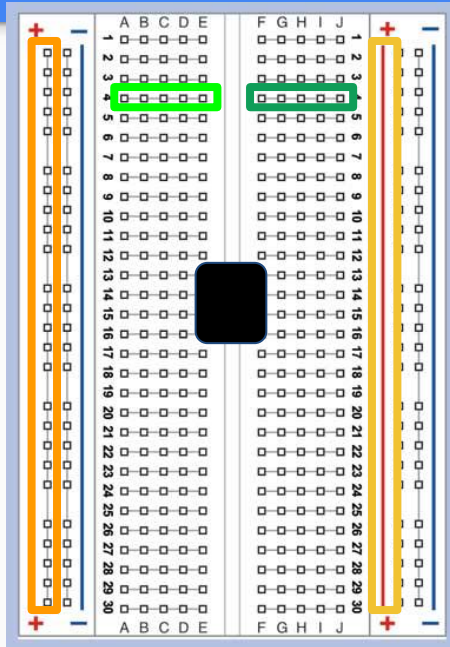

Notch

Rails

- Numbered rows are connected
 - Not connected over the notch!
- Rails connected vertically, but not to each other
 - The 2 red rails are NOT connected
- IC chips like op amps need to straddle the notch
 - Otherwise you'll short the pins together
- Rails are reserved for power traces.
 - + for DC voltage like 3.3V, - for gnd
- Color code wires for easier debugging
 - Red for power, black for gnd
- Keep things planar (flat)! Avoid excessively long wires

Lab Kit Op-Amps

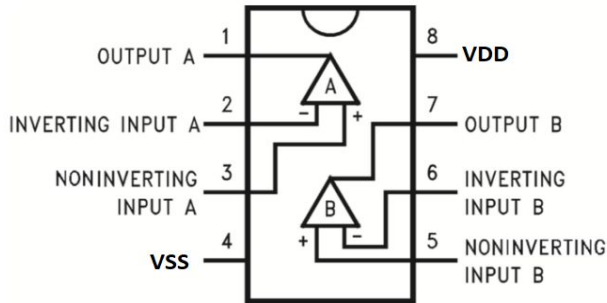

- Match the notch with the diagram
- 2 op-amps on one chip
- Must straddle the notch!
- Op-amp must be powered to provide at output

Today's Circuit

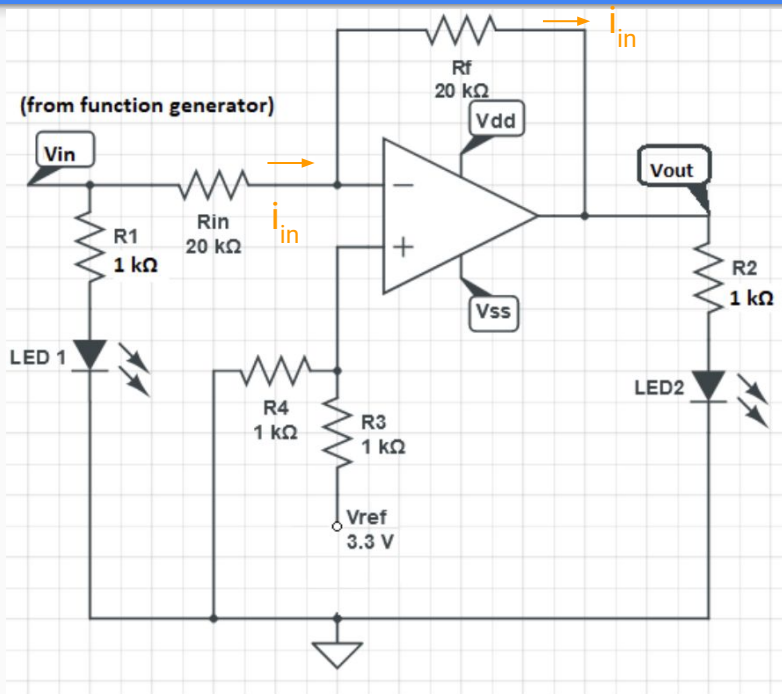

- Inverting amplifier, but with an offset
- No current into inputs of op amp, so

$$i_{in} = (V_{in} - V^-) / R_{in} = (V^- - V_{out}) / R_f$$

- $V^- = V^+$, and solving for V_{out} we get:

$$V_{out} = -(R_f / R_{in}) V_{in} + (1 + R_f / R_{in}) V^+$$

- Plug in resistance values:

$$V_{out} = -V_{in} + 2(V_{ref} / 2) = -V_{in} + 3.3V$$

Debugging 101

- Bugs happen (VERY often) - need skills to identify and fix them
 - Debugging circuits is like debugging a software program
 - Use tools like an oscilloscope to debug instead of a debugger
- Test often!
 - Take advantage of modularity and test individual parts of your circuit and test as you go
 - Make sure you see what you expect
- The oscilloscope is your friend.
 - Use it to gather clues as to what's going wrong
- Build cleanly - staff will not debug spaghetti
- Plan where components will go ahead of time
 - Tinkercad is a great tool to use for this

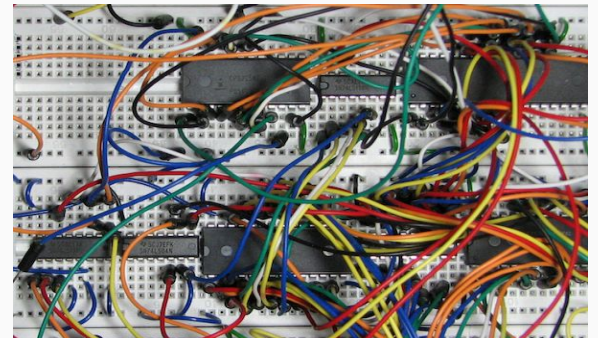

Common Bugs

- Grounds (breadboard ground, equipment grounds) need to all be connected/shorted
- LEDs have orientation
 - Anode (+): longer leg
 - Cathode (-): shorter leg
- Need to power op-amp with V_{dd} and V_{ss}

Reminders

- Collaboration is extremely important. Collaborate not just with your lab partner, but with everyone around you.
- Don't be afraid to ask questions if something doesn't make sense! Submit to help queue as often as you like.
- We are here to support you.

Lab Checkoff

1. **Open the lab** (can use Datahub link or download ipynb files)
2. **Read** Lab 1 Note and 16B Debugging Guide in the ipynb
3. **Watch** Lab Equipment videos in the ipynb
4. **Build** a inverting amplifier with LEDs

Requirements for checkoff:

- a) Show behavior of LEDs
- b) Show input and output signals on oscilloscope
- c) **Have ALL Qs answered in ipynb** and be prepared to answer checkoff Qs

Make sure you're marked as checked off before you leave!

Important Forms/Links

- Help request form: <https://eecs16b.org/lab-help>
- Checkoff request form: <https://eecs16b.org/lab-checkoff>
- Extension Requests: <https://eecs16b.org/extensions>
- Slides: <https://links.eecs16b.org/lab1-slides>

Equipment Training

TAs will give these live demos during section, but please refer to these slides and the resources in the Jupyter notebook as a supplement to the demos.

Power Supply

- Use to generate DC voltages for our circuits.
- +6V, +25V, -25V channels
- Voltage limit: set to maximum output voltage needed
- Current limit: set to 100mA = 0.1A
- For this lab: use +6V channel

Multimeter

- Use to measure voltage, current, resistance
- Continuity test: plays a sound if there is electrical connection
 - Can use to check if power and ground are shorted
- Can also use multimeter provided in lab kits

Function Generator

- Use to generate waveforms (square wave, sinusoids, etc.)
- Use Black cable, NOT the Gray cable
- Channel Setup -> Output Load: Always use High Z
- Waveforms
 - Chose type: square wave, sine wave, etc.
- Parameters
 - Adjust frequency, period, amplitude, phase, offset, duty cycle, etc.
- For this lab: generate a sine wave

Oscilloscope

- Use to view waveforms (square wave, sinusoids, etc.)
- Use Gray cable, NOT the Black cable
- Probe test: Follow instructions in equipment guide to view square wave
- Use knobs to adjust horizontal, time division; vertical, voltage division; vertical shift
- Trigger
 - Use to view static signal
- Cursors/Meas
 - Use to take measurements
- For this lab: view sine wave at input and output of inverting amplifier