

## Lab 4: Sensing Part 1

In the previous lab, you built the S1XT33N’s legs: the motor controller circuits that enable it to move around and the encoder circuits to sense how far and fast S1XT33N has moved. However, you might have noticed that the range of motion is quite limited when we are using the lab station’s DC power supply to power our circuits. We need a portable way to power your circuits so that S1XT33N can freely roam on the ground. Also, our end goal is to have S1XT33N be voice-controlled, and in order to do that, we need a way for S1XT33N to listen to what you’re saying. So, in this lab, you will be building voltage regulator circuits that enable us to power our circuits with batteries (a portable voltage source) and S1XT33N’s “ears”: the mic board circuit that will pick up your voice and convert it into an electrical signal, as well as the surrounding biasing circuits that the mic board requires to function as desired for our circuit.

The goals of this lab are as follows:

- Construct the voltage regulator circuits
- Build the biasing circuit with the mic board
- Tune the mic board and measure the frequency response

### Part 1: Regulator Circuits

S1XT33N, like any other electronics, requires power to run. If we were only using it at the lab stations, we could just hook it up to the DC power supply. However, because we want to let S1XT33N roam freely on the ground without confinement to a lab station, we need to power it with a more portable source: batteries. However, we only have access to 9V batteries, which cannot directly supply the 3.3V and 5V we need for powering the rest of our circuitry. In most electrical systems, you only have access to one or two main supply voltages (such as 9V from a 9V battery) that often times are not what you need for your circuits. This is where the voltage regulators come in.

In order to generate specific voltages, you need to build a voltage regulator to “regulate” the supply voltage to what you require. The inner workings of these regulators is beyond the scope of the class, so we will not discuss them in detail, nor build our own. In our kits, we have provided you 2 regulator components that will work so long as you build the necessary circuits around them: the 5V regulator and 3.3V regulator. These components will take the 9V from one of your batteries and generate 5V and 3.3V, respectively. Although the Arduino has internal 3.3V and 5V regulators to produce 3.3V and 5V outputs, we typically do not want to use those to power the rest of our circuit because of the Arduino’s limited output current.

#### 5V Regulator Circuit

The LM340T5 is really just meant for 5V regulation (hence the 5 in LM340T5), So we use it to regulate the 9V input down to a 5V output. Adding “decoupling” capacitors to the input and output is useful for removing all sorts of noise and interference from the 9V supply and the 5V output to make them both more stable.

The pinout is reproduced below for your convenience. The image is taken from a front angle where the metal tab that sticks out is at the back of the regulator. Note the difference between the 5V regulator and 3.3V regulator: the 3.3V regulator has 2 rectangular notches/cutouts in the metal tab, while the 5V regulator does not. The 5V regulator also has a thicker metal tab than the 3.3V regulator. You don’t want to accidentally confuse the two and wind up frying your circuit components by plugging them into the wrong voltage!

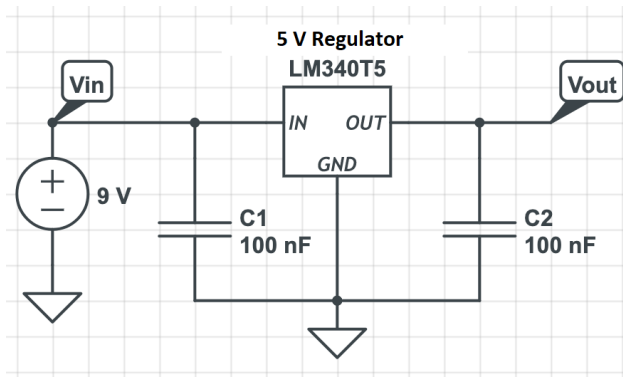

INPUT	1
GND	2
OUTPUT	3

### 3.3V Regulator Circuit

The LM317KCT is a multi-use device. It can be used to regulate current (current source) or voltages with different values. We will use it as a voltage source supplying 3.3V – but that can be easily changed by using different resistors. The way the LM317KCT works is that it has internal circuitry (using op-amps as well!) that keeps a stable 1.2V between the ADJUST pin and the OUTPUT pin.

We have given you working resistor values that yield approximately 3.3V in the lab. The resistance of  $R_1 || R_2 = 0.500k\Omega$ , so the total current through them will sum to  $\frac{1.2V}{0.5k\Omega} = 2.4mA$ . That is also the total current going through  $R_3 || R_4 = 0.86k\Omega$  (no current flows into the ADJUST pin). So the voltage across  $R_3$  and  $R_4$  will be  $2.06V$ . This also means that the voltage at the output will be  $2.06V + 1.2V = 3.26V \approx 3.3V$  (Remember that resistors have variation and are not exact in practice). If you're interested in learning more details of how this regulator works, as well as more applications for this regulator, please refer to the [datasheet](#).

The pinout table is reproduced below. The image is taken from a front angle where the metal tab that sticks out is at the back of the regulator.

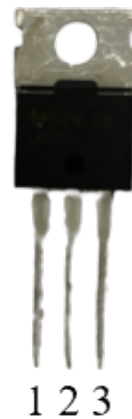
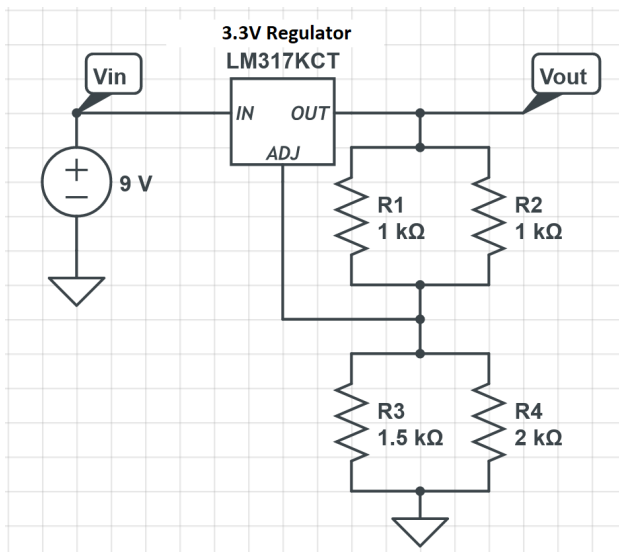

ADJUST	1
OUTPUT	2
INPUT	3

## Part 2: Mic Board Circuits

Our biasing<sup>1</sup> circuits will provide signals for the OS1 (DC Offset) and OS2 (Level Shift) pins of the mic board so that the mic board can function properly. Before we build the biasing circuit with the mic board, let's discuss the mic board's circuit below (this is the schematic of what is on the mic board PCB, or printed circuit board):

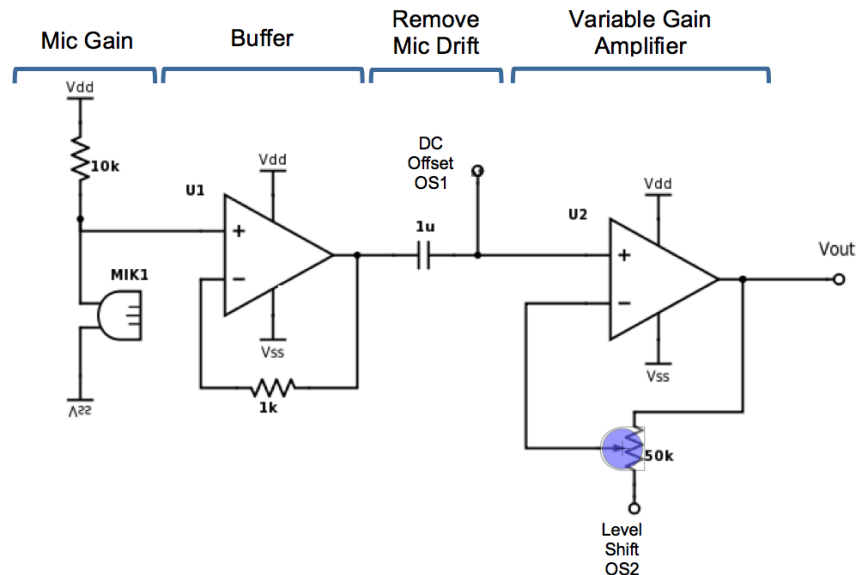

There are a few key stages and components to the mic board:

- **Microphone Gain:** The electret microphone behaves as a *variable current source* depending on the size of the sound waves hitting it. Current signals are generally more difficult to work with than voltage signals, so we turn that into a voltage signal using the resistor in the Mic Gain part of the circuit. If you would like to learn more about these electret microphone after doing the lab, please read the (optional) [extra lab reading note](#).
- **Buffer:** This buffer helps keep the amplifier and the capacitor from loading (affecting) the microphone by preventing the rest of the circuit from drawing current from the Mic Gain stage. It looks a little different from the buffers we usually use (there's a resistor in the feedback loop, whose purpose is beyond the scope of this class), but it functions just the same.
- **Remove Mic Drift:** A capacitor placed between one circuit stage and the next is usually called a [coupling cap](#). It really just acts as a high pass filter with a very low cutoff frequency, allowing us to block DC (frequency = 0) and other low frequency components while letting AC/high frequency components to pass. The microphone naturally has a lot of low frequency drift that is hard to predict, so we use this coupling cap to remove any DC offset and low frequency noise. This allows us to ignore whatever DC value the mic gain stage had, and add in a suitable DC value in the next stage. To add in a DC offset, we cannot directly connect the output of the buffer to the DC value since these two voltages are not equal but would be in the same node - hence why we need the coupling cap.
- **DC Offset:** For this project, **you will not have a negative power source**, since the Arduino cannot take negative voltage inputs. If you center your signal around ground, then you will lose the negative half of the signal as soon as you send it through the op-amp because your op-amp won't be able to output those negative voltages (since all your op-amps'  $V_{SS}$  pins will be set to ground). To get around this problem, we want to center our signal in the center of our available voltage range (0V to 5V on the Arduino, but we will be working with 0V to 3.3V), which is 1.65V. Here is where we will connect OS1 from our biasing circuit via a 100k resistor in order to accomplish this goal. The reason the resistor is 100k $\Omega$  is because we create an unintentional high pass filter with this resistor and the coupling capacitor in the previous stage. In order to minimize the effects of this

<sup>1</sup>"Biasing" a circuit means establishing predetermined voltages or currents at various points of the circuit in order to construct the proper operating conditions for the components [[Wikipedia](#)].

unwanted high pass filter, we set the resistor value to  $100\text{k}\Omega$  so that the filter's cutoff frequency is  $10\text{ rad/s}$ , or  $1.59\text{ Hz}$ , effectively passing virtually all of the signals we pass into the mic board without attenuation.

Note that you will have to be careful and remember that a DC offset exists or it could become troublesome later on in the amplifier stage of the mic board. Think of a  $0.1\text{V}$  DC signal. Now put that signal through a non-inverting op-amp with a gain of 100 and a reference voltage of  $0\text{V}$ . Suddenly that  $0.1\text{V}$  DC signal becomes  $10\text{V}$ !

- **Level Shift:** When we introduce the DC offset at OS1, we have to adjust our amplifier to expect signals centered around that offset. We will explain this further when we discuss the off-board biasing circuit below.
- **Amplifier:** Finally, the mic board uses a non-inverting amplifier (with a potentiometer) to amplify the microphone signal. Note that OS2 is on the inverting terminal of the op-amp - we use this to help us deal with our DC offset problem.

Now, let's move **off** the mic board and onto our biasing circuits. The schematic is reproduced below for your convenience.

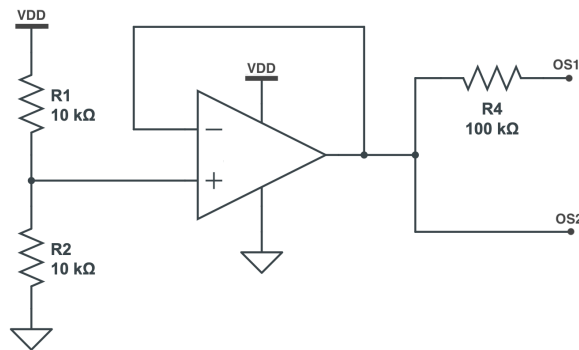

- **OS1: DC Offset**

Because we need our signal to be centered in our target range ( $0 - 3.3\text{ V}$ ), we will need to set the DC offset to the midpoint of this range:  $1.65\text{ V}$ . This can easily be accomplished with a voltage divider of two equal resistors from the  $3.3\text{ V}$  rail to ground.

- **OS2: Level Shift**

When we introduce the DC Offset, we will encounter a problem when the signal passes through the non-inverting amplifier: that DC offset will be amplified along with the rest of the signal! This is because the amplifier will amplify the signal as referenced from *ground*. This is the key problem here.

If we want to avoid amplifying the DC offset, what value should we use for the amplifier's reference voltage?

If you guessed  $1.65\text{ V}$ , congratulations! This is the key idea to a level-shifter.

We connect OS2 to  $1.65\text{V}$  when building the mic board circuits - this is how we tell the non-inverting amplifier to use  $1.65\text{V}$  as a reference. If you would like a review of how to add a reference/virtual ground to an amplifier circuit, see [lab note 1](#).

## Part 2A: Frequency Response of the Speaker-Microphone System

The system you are building in this lab consists of the microphone on the mic board as well as the speaker you're using to play music. You must consider the ability of your speaker to reliably reproduce the desired frequency at a volume large enough to excite the microphone, and the ability of your microphone to pick up and record the desired frequency. Ideally, your speaker will be able to play all frequencies at the same volume, and your microphone will pick up all frequencies equally.

However, due to the physical limitations of your speaker and microphone, for some frequency ranges, the signal your speaker-microphone system generates will be highly attenuated. You will be filtering the output of the mic board circuit to partition the frequency spectrum for next week's lab and to extract specific frequency ranges to better sample voice commands later in the project, so you must consider the non-ideal frequency response when designing your filters. *How can I add gain to some frequencies and not others? Which frequencies should I choose?* In order to design effective filters, we must answer these questions, and to do so, we must first identify the speaker-microphone system's frequency response. We will do this empirically: as detailed in the lab ipynb, you will play a range of frequencies on your speaker and record the peak-to-peak of the microphone's received wave at that frequency.

We have attached a page of handwritten notes to the end of this note detailing the different parts of the mic board that students have found helpful in the past. Feel free to look through it for another review of the mic board schematic in a less text-heavy format.

## References

Original Project Part 1 notebook written by Nathaniel Mailoa and Emily Naviasky (2016).

Horowitz, P. and Hill, W. (2015). *The Art of Electronics*. 3rd ed. Cambridge: Cambridge University Press, ch 4.

Horowitz, P. and Hill, W. (2015). *The Art of Electronics*. 3rd ed. Cambridge: Cambridge University Press, ch 2.

Sedra, A. S. and Smith, K. C. (2015). *Microelectronic Devices and Circuits*. 7th ed. Oxford: Oxford University Press, ch 3.

Sedra, A. S. and Smith, K. C. (2015). *Microelectronic Devices and Circuits*. 7th ed. Oxford: Oxford University Press, ch 6.

*Written by Mia Mirkovic (2019)*

*Edited by Steven Lu, Yi-Hsuan Shih (2021). Version 2.0, 2021. Edited by Megan Zeng, Steven Lu (2022). Version 3.0, 2022.*

## you're given this! Mic Board Schematic:

we're building this! (it connects to the mic board)

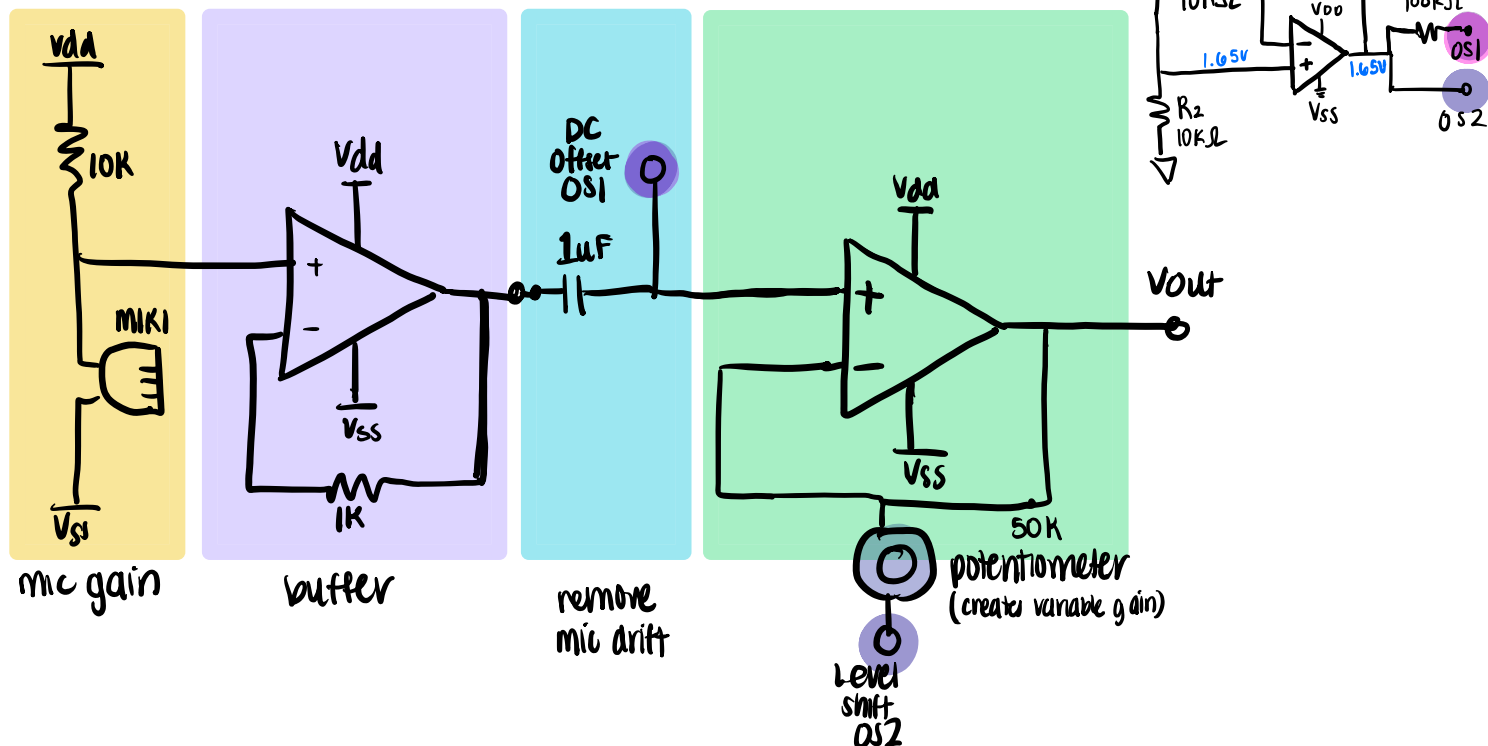

### ① mic gain

- our mic is a variable current source, but we convert it to a voltage signal by placing it in series with a 10K resistor

### ② Buffer

- This keeps the rest of our circuit from affecting our mic signal.

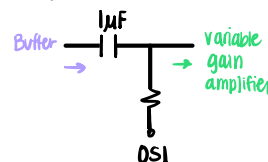

### ③ Remove Mic Drift

- The 1uF capacitor is a coupling capacitor. This means after settling, it functions as a short to AC signals (most signals we work with are high enough frequency to make this generalization), but as an open circuit to DC voltage (think about impedance of a capacitor  $\frac{1}{j\omega C}$  to understand this).
- **DC Offset 1 (OS1)** - since we cannot have negative voltages (our rails are 0V & 3.3V and the MSP430 can't handle it), OS1 serves to center our signal at 1.65V.
- We need to connect OS1 through a 100K resistor, otherwise it would be as if we're saying our AC voltage centered at 0V is equal to the voltage at OS1 (1.65V), which would be problematic.
- This then creates an unintended high pass filter, so you will see that RC was strategically chosen to have a low cutoff frequency of 1.59Hz and let all our signal through.

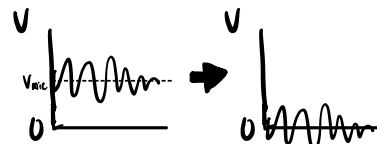

high pass filter with cutoff  $f = \frac{1}{2\pi RC} = \frac{1}{2\pi(1\mu F \cdot 100k\Omega)} = 1.59\text{Hz}$

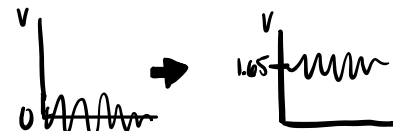

### ④ Non-inverting amplifier

- Our amplifier uses a potentiometer for variable gain
- **Level Shift Offset (OS2)** - This serves as a virtual ground, changing the reference point so our amplifier doesn't amplify the 1.65V offset. If we didn't have this (say OS2 was 0V), then our output signal would likely rail.

