

**EECS 16B**

**Designing Information Devices and Systems II**  
**Lecture 1**

Prof. Sayeef Salahuddin

Department of Electrical Engineering and Computer Sciences, UC Berkeley,  
sayeef@eecs.berkeley.edu

# Reading Material

---

For the first 10 classes we will closely follow

Electrical engineering: principles and applications 6th edition  
Allan R Hambley

- See notes link in the website
- Also will be available through e-reserves

# Capacitors and Inductors

---

- Outline
  - Capacitor
  - Inductor

# Capacitors (Review)

- Two conductors (usually metal) separated by an insulator
- A capacitor stores charges ( $q$ )
- The stored charge is proportional to the difference in potential ( $v$ ) across the metal plates. The proportionality constant is known as capacitance ( $C$ )

$$q = Cv$$

- Charge is positive on the metal plate with high potential
- Complementary charge on two plates creates an electric field ( $\zeta$ ) that points from positive to negative charges

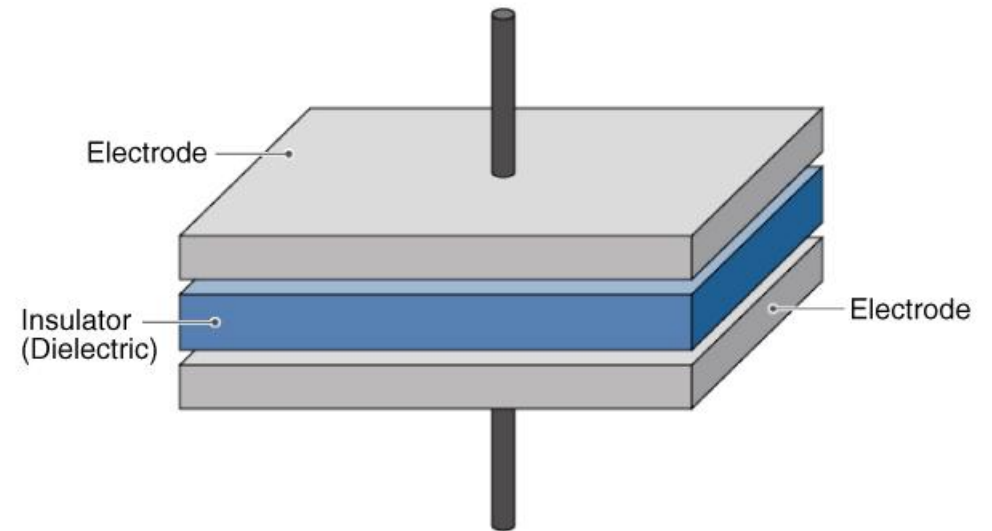

Unit: Farad (coulomb/volt)

# Capacitors (Review)

The potential difference between two plates is held by the electric field is equal to the product of the electric field and the distance of the conductors (thickness of the insulator)

$$v = \zeta \times d$$

Then

$$\frac{q}{C} = \zeta \times d$$

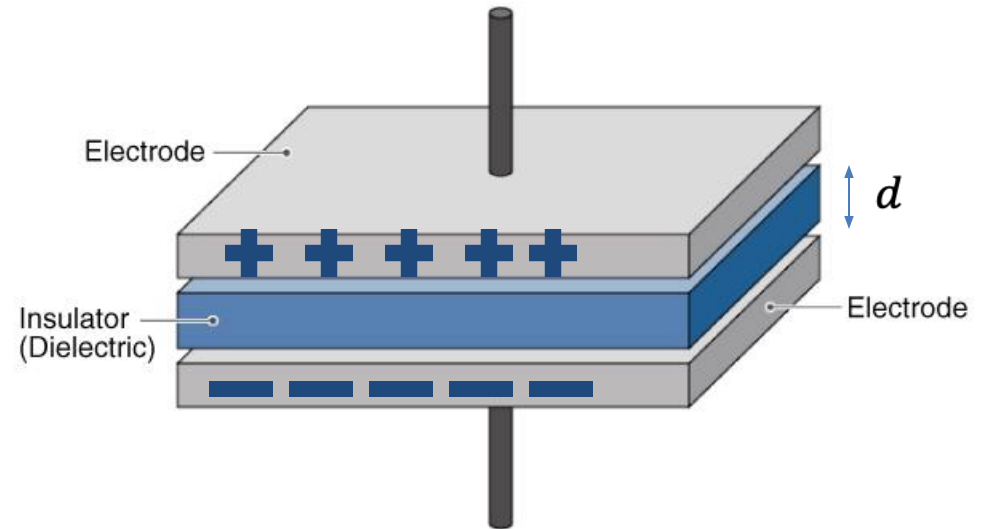

The ratio of charge and electric field in an insulator is called the permittivity ( $\epsilon$ ). Unit: Farad/meter

Therefore,  $C = \frac{\epsilon}{d}$

# Current flow through a Capacitor

**Remember:** Electrons flow in the opposite direction of current flow

If a current is flowing to the upper plate, electrons leave that plate resulting in a net positive charge.

The positive charge generates an electric field that brings electrons to the bottom plate at the same rate electrons are leaving the upper plate. Thus current flow is maintained.

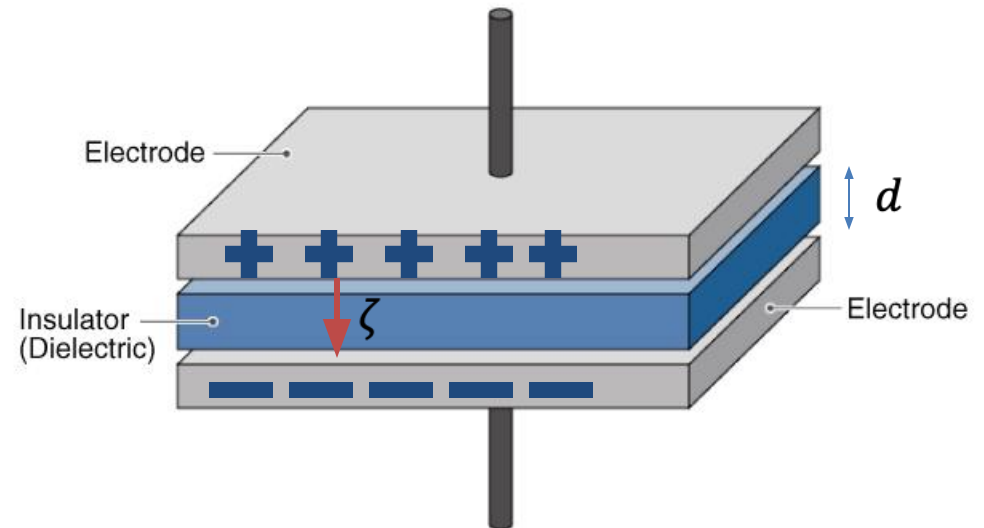

# Current flow in a Capacitor

Current flow through a capacitor is proportional to the rate of change in potential difference of the plates

$$i = C \frac{dv}{dt}$$

## Time Varying Voltage

$$v(t) = \frac{1}{C} \int_{t_0}^t i dt + v(t_0)$$

Also, from the definition of current

$$i = \frac{dq}{dt}$$

## Time Varying Charge

$$q(t) = \int_{t_0}^t i dt + q(t_0)$$

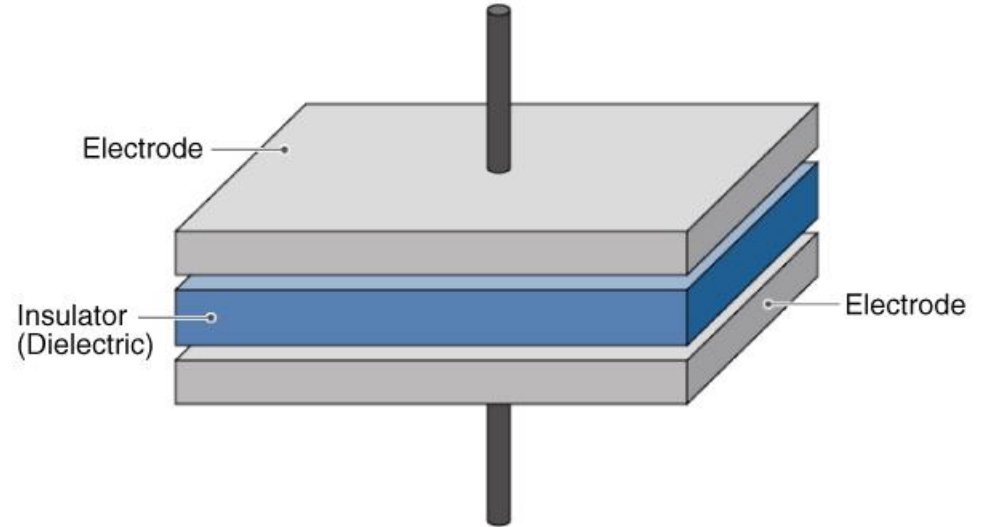

# Stored Energy in a Capacitor

---

- Capacitors store energy in the electric field
- Power ( $p$ ) delivered to a circuit element is the product of the current and the voltage.
- Energy ( $w$ ) is the power integrated over time.

$$p(t) = v(t)i(t)$$

$$p(t) = v(t) \frac{Cdv(t)}{dt} = C \frac{v(t)dv(t)}{dt}$$

$$p(t)dt = Cv(t)dv(t)$$



# Voltage, Current and Energy in a Capacitor

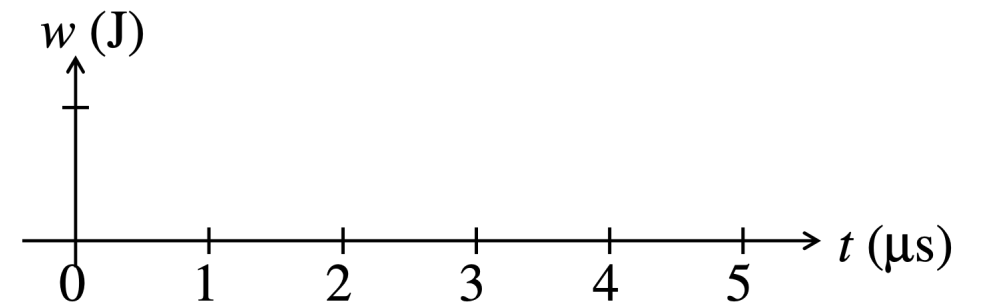
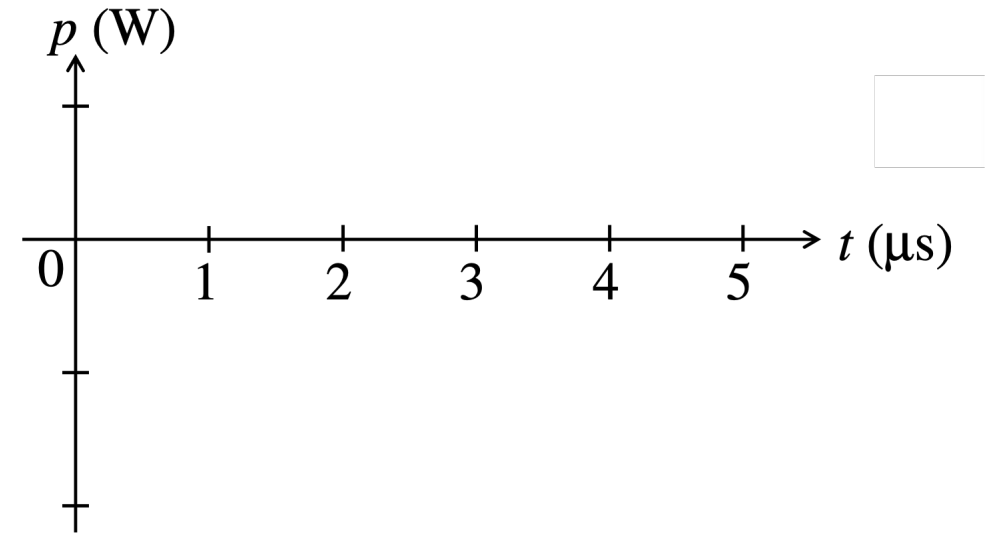
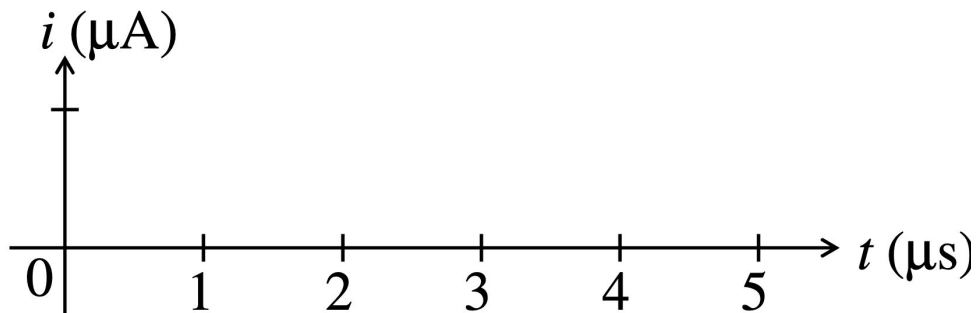
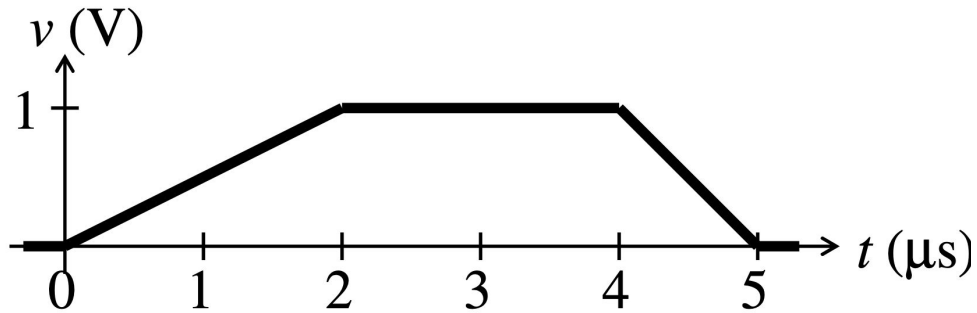

# Cause and Effect

---

# Series and Parallel Capacitors

Series:

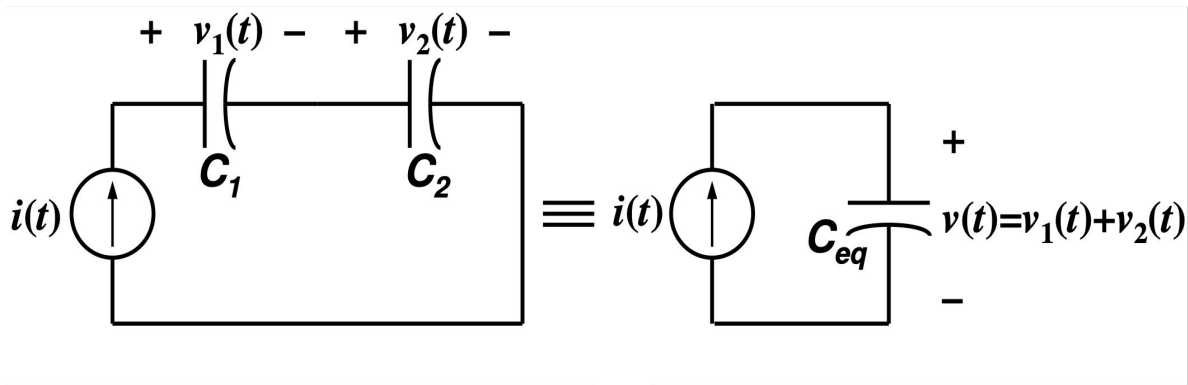

$$i = C_{eq} \frac{dv}{dt} = C_{eq} \frac{dv_1}{dt} + C_{eq} \frac{dv_2}{dt}$$

$$\frac{1}{C_{eq}} = \frac{1}{i / \frac{dv_1}{dt}} + \frac{1}{i / \frac{dv_2}{dt}}$$

Parallel:

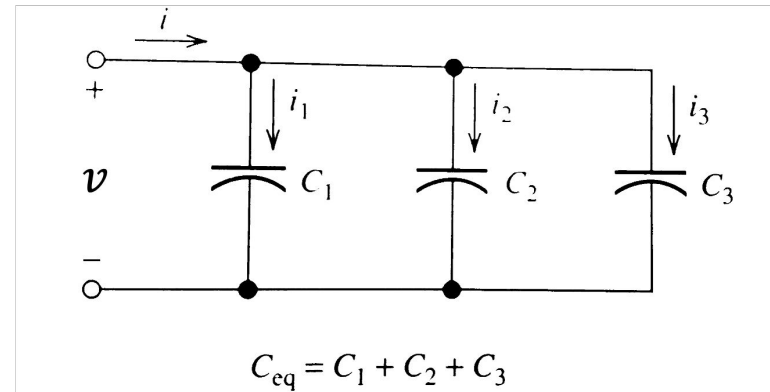

$$i = i_1 + i_2 + i_3 = C_1 \frac{dv}{dt} + C_2 \frac{dv}{dt} + C_3 \frac{dv}{dt}$$

# Inductors

---

Symbol:

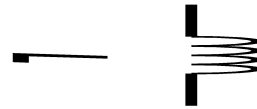

- Inductors store energy in the magnetic field
- Are made of current carrying coils wound around a magnetic core material (popular materials are various types of iron oxides – often called ferrites)
- Governed by Faraday's law of electromagnetic induction which states that a time-varying magnetic flux linking a coil induces a voltage across the coil which is proportional to the rate of change in the current. This proportionality constant is the inductance

$$v(t) = L \frac{di}{dt}$$



Image source: Digikey

Reciprocity says that a time-varying current flowing through a coil will create a time-varying magnetic flux

# Inductors

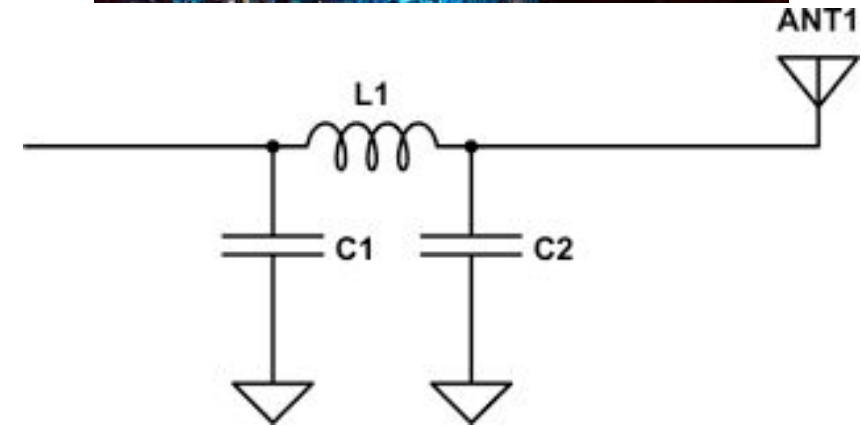
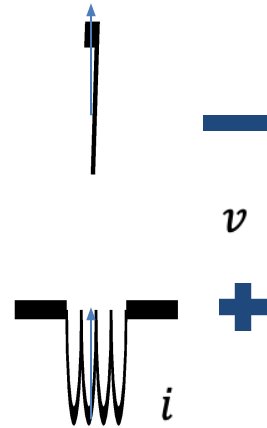
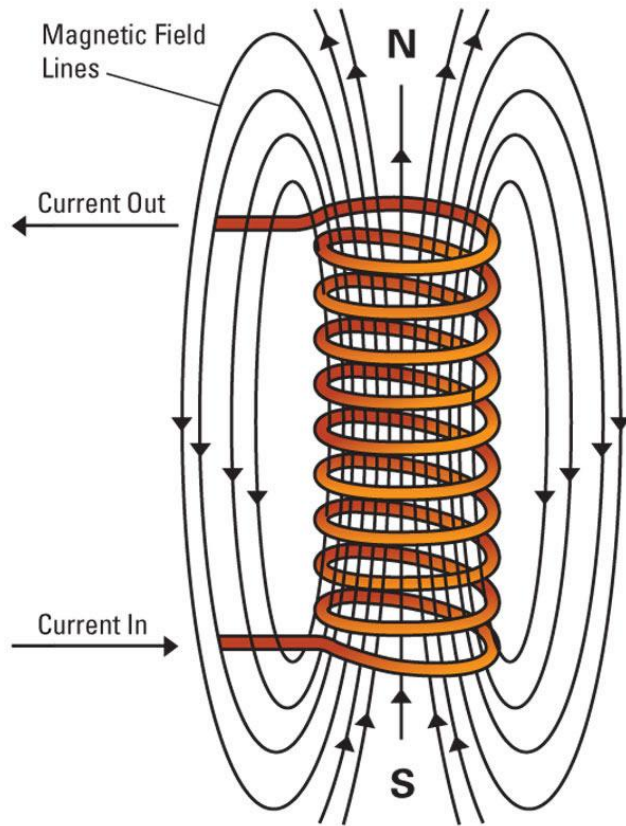

Communication needs sending and receiving of  
**C L**  
**Electro-Magnetic Wave**

# Current in an Inductor

---

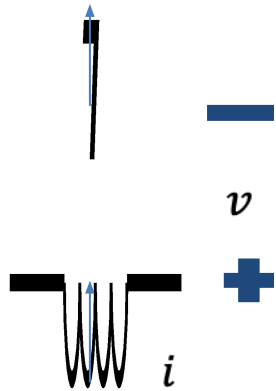

$$v(t) = L \frac{di}{dt}$$

$$i(t) = \frac{1}{L} \int_{t_0}^t v dt + i(t_0)$$

**Remember the capacitors**

$$i = C \frac{dv}{dt}$$

$$v(t) = \frac{1}{C} \int_{t_0}^t i dt + v(t_0)$$

# Cause and Effect

---

# Stored Energy in an Inductor

---

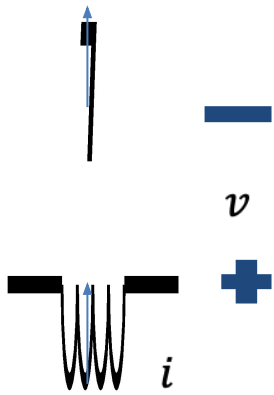

$$p(t) = v(t)i(t)$$

$$p(t) = i(t)L \frac{di(t)}{dt} = L \frac{i(t)di(t)}{dt}$$

$$p(t)dt = Li(t)di(t)$$



# Inductances in Series and Parallel

## Series: Common Current

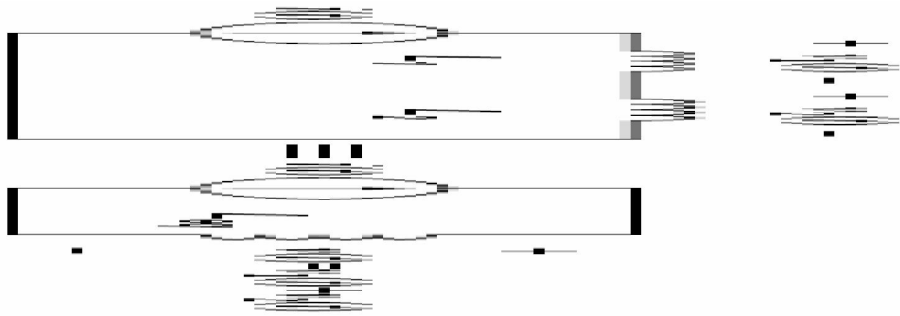

## Parallel: Common Voltage

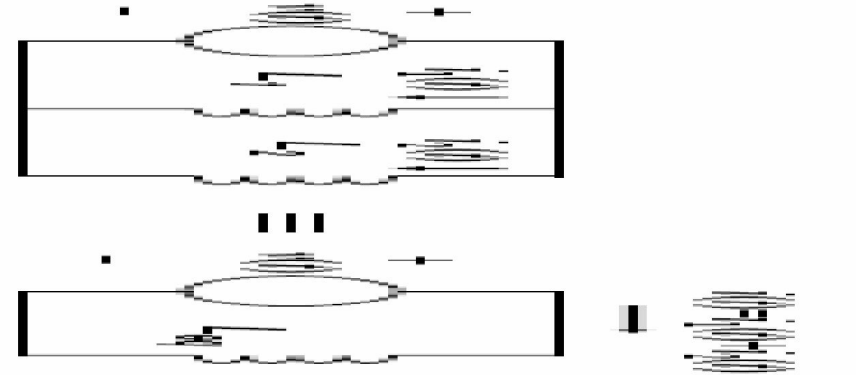

# Mutual Inductance

- Mutual inductance occurs when two windings are arranged so that they have a mutual flux linkage
- The change in current in one winding causes a voltage drop to be induced in the other

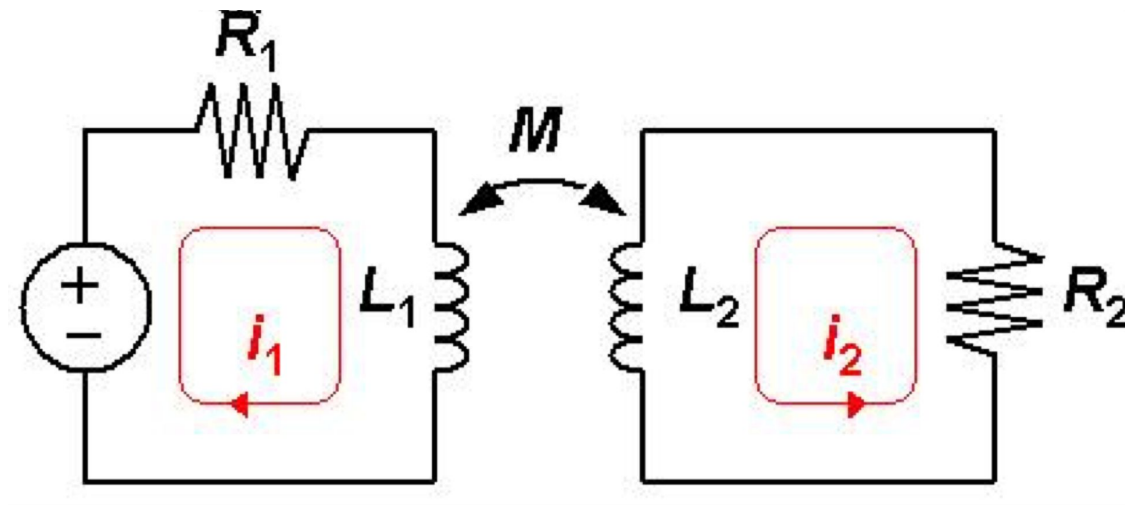

Transformers (adapters), motors, generators (electric cars)

# The Dot Convention

- If a current enters the dotted terminal of a coil, the reference polarity of the voltage induced in the other coil is positive at its dotted terminal.
- If a current leaves the dotted terminal of a coil, the reference polarity of the voltage induced in the other coil is negative at its dotted terminal.
- Total voltage induced in a coil is a summation of its own induced voltage and the mutually induced voltage

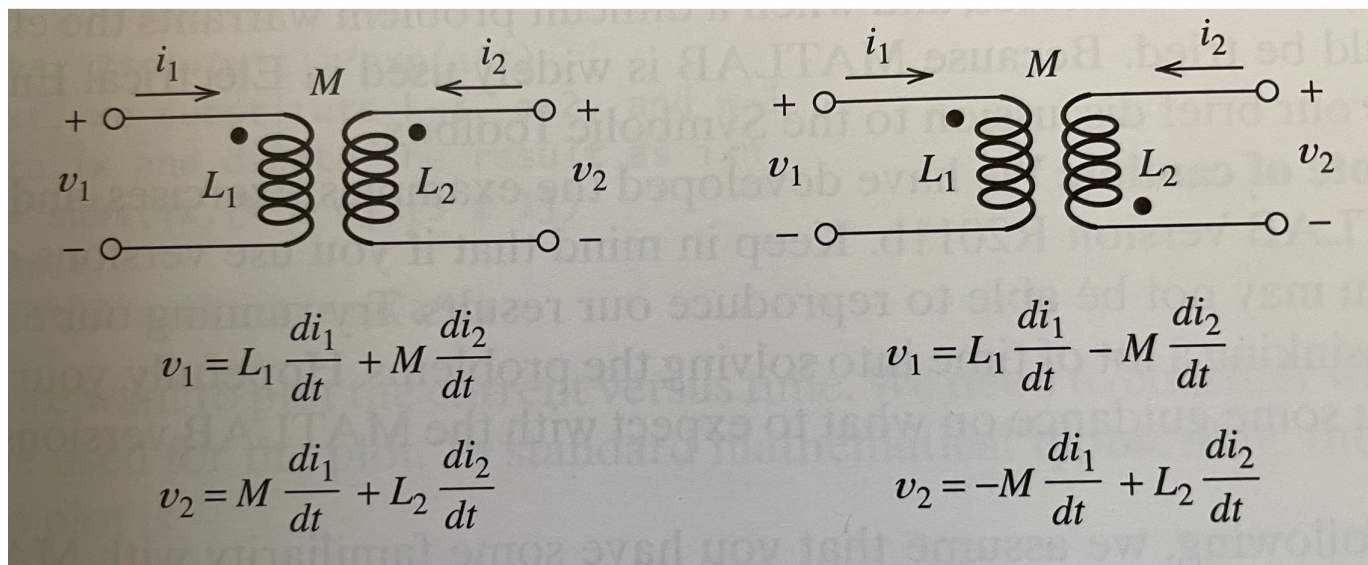

# Summary

## Capacitors:

$$i = C \frac{dv}{dt}$$

$$w = \frac{1}{2} C v^2$$

- $v$  cannot charge instantaneously
- $i$  **can** charge instantaneously (do not short circuit a charged capacitor)

- $N$  capacitors in series  $\frac{1}{C_{eq}} = \sum_{i=1}^N \frac{1}{C_i}$

- $N$  capacitors in parallel  $C_{eq} = \sum_{i=1}^N C_i$

## Inductors:

$$v = L \frac{di}{dt}$$

$$w = \frac{1}{2} L i^2$$

- $i$  cannot charge instantaneously
- $v$  **can** charge instantaneously (do not open an inductor with current)

- $N$  inductors in series  $L_{eq} = \sum_{i=1}^N L_i$

- $N$  inductors in parallel  $\frac{1}{L_{eq}} = \sum_{i=1}^N \frac{1}{L_i}$